

TENTATIVE

All information in this technical data sheet is tentative
and subject to change without notice.

5.0”WVGA

TECHNICAL SPECIFICATION

AA050MC01--T1

mitsubishi electric corp.

Date: Jun. 14,'11

CONTENTS

| No. | Item | Page |
|-----|---|----------------|
| -- | COVER | 1 |
| -- | CONTENTS | 2 |
| 1 | APPLICATION | 3 |
| 2 | OVERVIEW | 4 |
| 3 | ABSOLUTE MAXIMUM RATINGS | 5 |
| 4 | ELECTRICAL CHARACTERISTICS | 5, 6, 7 |
| 5 | INTERFACE PIN CONNECTION | 8, 9 |
| 6 | INTERFACE TIMING | 10, 11, 12, 13 |
| 7 | BLOCK DIAGRAM | 14 |
| 8 | MECHANICAL SPECIFICATION | 15, 16, 17, 18 |
| 9 | OPTICAL CHARACTERISTICS | 19, 20, 21 |
| 10 | RELIABILITY TEST CONDITION | 22 |
| 11 | OTHER FEATURE | 23 |
| 12 | HANDLING PRECAUTIONS FOR TFT-LCD MODULE | 24, 25 |

1. APPLICATION

This specification applies to color TFT-LCD module, AA050MC01--T1.

These specification papers are the proprietary product of Mitsubishi Electric Corporation (“MITSUBISHI”) and include materials protected under copyright of MITSUBISHI. No part of this document may be reproduced in any form or by any means without the express written permission of MITSUBISHI.

MITSUBISHI does not assume any liability for infringement of patents, copyrights or other intellectual property rights of third parties by or arising from use of a product specified in this document. No license, express, implied or otherwise, is granted under any patents, copyrights or other intellectual property rights of MITSUBISHI or of others.

MITSUBISHI classifies the usage of the TFT-LCD module as follows. Please confirm the usage before using the product.

(1) Standard Usage

Computers, office equipment, factory automation equipment, test and measurement equipment, communications, transportation equipment(automobiles, ships, trains, etc.), provided, however, that operation is not influenced by TFT-LCD directly.

(2) Special Usage

Medical equipment, safety equipment, transportation equipment, provided, however, that TFT-LCD is necessary to its operation.

(3) Specific Usage

Cockpit Equipment, military systems, aerospace equipment, nuclear reactor control systems, life support systems and any other equipment. MITSUBISHI should make a contract that stipulate apportionment of responsibilities between MITSUBISHI and our customer.

The product specified in this document is designed for “Standard Usage” unless otherwise specified in this document. If customers intend to use the product for applications other than those specified for “Standard Usage”, they should first contact MITSUBISHI sales representative for it's intended use in writing.

MITSUBISHI has been making continuous effort to improve the reliability of its products. Customers should implement sufficient reliability design of their application equipments such as redundant system design, fail-safe functions, anti-failure features.

MITSUBISHI assumes no responsibility for any damage resulting from the use of the product that does not comply with the instructions and the precautions specified in this document.

Please contact and consult a MITSUBISHI sales representative for any questions regarding this product.

2. OVERVIEW

AA050MC01--T1 is 5.0" color TFT-LCD (Thin Film Transistor Liquid Crystal Display) module composed of LCD panel, driver ICs, control circuit, backlight unit, and touch panel.

By applying 8 bit digital data, 800×480 , 16.7M-color images are displayed on the 5.0" diagonal screen. Input power voltages are 3.3 V and 5.0 V for LCD driving.

The type of data and control signals are digital and transmitted via CMOS interface per Typ. 33.5 MHz clock cycle.

Driver circuit for LED backlight and controller for touch panel are not included in this module. General specifications are summarized in the following table:

| ITEM | SPECIFICATION |
|---------------------------------|---|
| Display Area (mm) | 108.0(H) × 64.8(V) (5.0-inch diagonal) |
| Number of Dots | 800 × 3 (H) × 480 (V) |
| Pixel Pitch (mm) | 0.135(H) × 0.135 (V) |
| Color Pixel Arrangement | RGB vertical stripe |
| Display Mode | Normally black |
| Number of Color | 16.7M |
| Luminance (cd/m ²) | 250 |
| Viewing Angle (CR ≥ 10) | -85~85° (H), -85~85° (V) |
| Surface Treatment (Touch panel) | Clear and hard-coating 3H |
| Electrical Interface | CMOS |
| Module Size (mm) | 118.5(W) × 77.8(H) × 4.7(D) *) |
| Module Mass (g) | 89 |
| Backlight Unit | LED, Edge-light |
| Touch Panel | 4-wire analog resistive |

*) Without FPC

Characteristic value without any note is typical value.

3. ABSOLUTE MAXIMUM RATINGS

| ITEM | SYMBOL | MIN. | MAX. | UNIT |
|--|-----------------------------|------|------|------|
| Power Supply Voltage for LCD 1 | VCC | -0.3 | 5.0 | V |
| Power Supply Voltage for LCD 2 | AVDD | -0.3 | 5.5 | V |
| Logic Input Voltage | VI | -0.3 | 5.0 | V |
| Backlight (LED) Current | IF | -- | 30 | mA |
| Touch Panel Voltage | TPV | -- | 7.0 | V |
| Operation Temperature (Touch Panel) <small>Note 1,2)</small> | T _{op(TouchPanel)} | -20 | 60 | °C |
| Operation Temperature (Ambient) <small>Note 2)</small> | T _{op(Ambient)} | -20 | 60 | °C |
| Storage Temperature <small>Note 2)</small> | T _{stg} | -30 | 80 | °C |

[Note]

1) Measured at the center of active area and at the center of panel back surface

2) Top, Tstg ≤ 40°C : 90%RH max. without condensation

Top, Tstg > 40°C : Absolute humidity shall be less than the value of 90%RH at 40°C without condensation.

4. ELECTRICAL CHARACTERISTICS

(1) TFT- LCD

Ambient temperature: Ta = 25°C

| ITEM | SYMBOL | MIN. | TYP. | MAX. | UNIT | Remarks |
|---------------------------------|--------|------|--------|------|--------|-----------------------------|
| Power Supply Voltage for LCD 1 | VCC | 3.0 | 3.3 | 3.6 | V | *1) |
| Power Supply Voltage for LCD 2 | AVDD | 4.8 | 5.0 | 5.2 | V | *1) |
| Power Supply Current for LCD 1 | ICC | -- | 7.4 | 17.0 | mA | *2) |
| Power Supply Current for LCD 2 | AIDD | -- | 38.0 | 62.0 | mA | *2) |
| Permissive Input Ripple Voltage | VRP | -- | -- | 100 | mVp-p | VCC = +3.3V AVDD = +5.0V |
| Logic Input Voltage | High | VIH | 0.7VCC | -- | VCC | V |
| | Low | VIL | 0 | -- | 0.3VCC | V |

*1) Power and signals sequence:

- 0.1 ms ≤ t1 ≤ 10 ms 160 ms ≤ t6
- 0 < t2 ≤ 50 ms 160 ms ≤ t7
- 0 < t3 ≤ 50 ms 0 ms ≤ t8
- t4 ≤ 10 ms 1 s ≤ t9
- 0 < t5 ≤ 50 ms

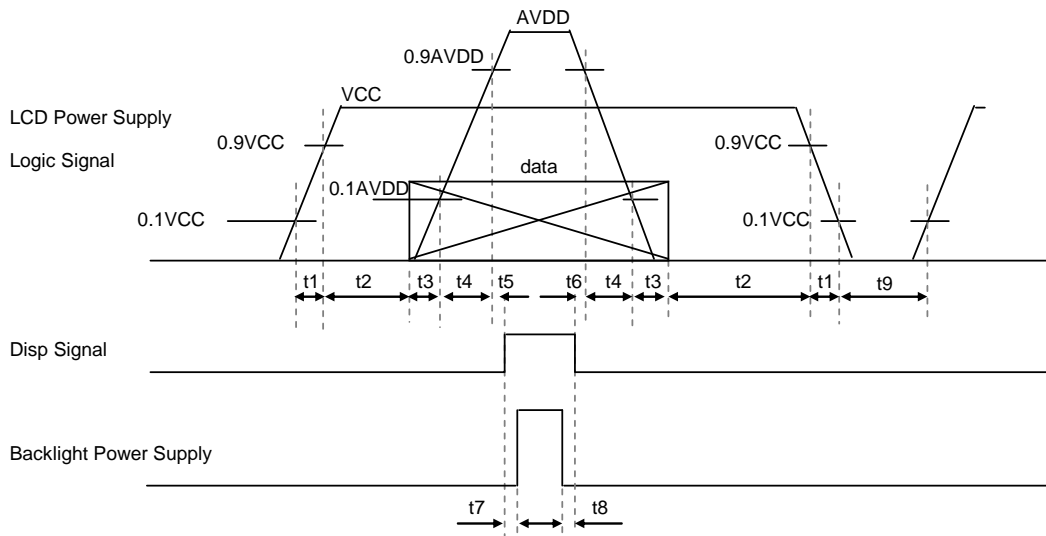

data: RGB DATA, DCLK, DENA, HD, VD, SC

*2) VCC = + 3.3 V, AVDD=+5.0V, f_H=31.5kHz, f_V=60Hz, f_{CLK}= 33.5MHz

Display image at typical power supply current value is 256-gray-bar pattern (8 bit), 480 line mode.

(2) Backlight

| ITEM | SYMBOL | MIN. | TYP. | MAX. | UNIT | Remarks |
|-------------|--------|------|--------|------|------|----------------------------|
| LED Voltage | VF | -- | (22.2) | 23.1 | V | IF = 15 mA, Ta = 25°C, *2) |
| | | -- | -- | 23.5 | V | IF = 15 mA, Ta = 0°C |
| | | -- | -- | 23.8 | V | IF = 15 mA, Ta = -20°C |
| LED Current | IF | -- | 15.0 | 20.0 | mA | Ta = 25°C, *1), *3) |

[Note]

*1) Constant Current Drive

*2) The Voltage deviation between strings: $|V_{f1} - V_{f2}| \leq 2V$

*3) LED Current measurement method

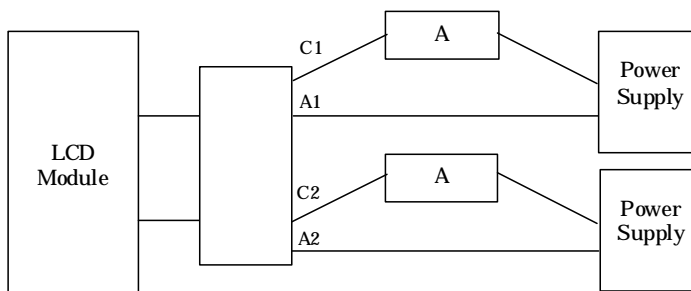

Diode IF-Ta CHARACTERISTICS DIAGRAM

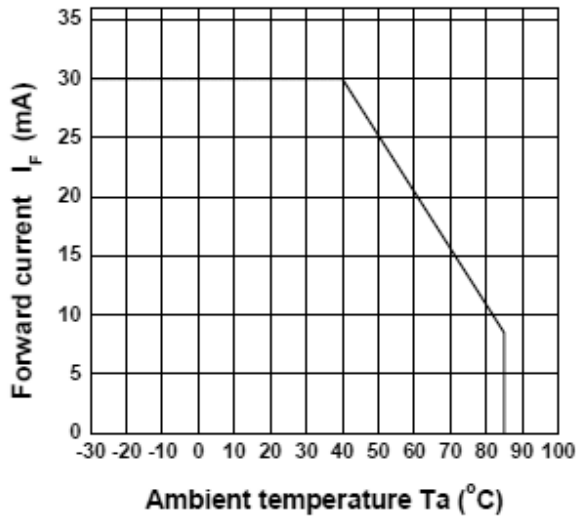

(3) Touch Panel

Electrical Characteristics

| ITEM | MIN. | TYP. | MAX. | UNIT | Remarks |
|-----------------------|------|------|------|------------|---------------------------|
| Linearity | -1.5 | -- | 1.5 | % | Analog X and Y directions |
| Terminal Resistance | 490 | -- | 1144 | Ω | X |
| | 225 | -- | 526 | Ω | Y |
| Insulation Resistance | 20 | -- | -- | M Ω | DC 25 V |
| Voltage | 3.0 | 5.0 | 7.0 | V | DC |
| Chattering | -- | -- | 10 | ms | |

*) Do not operate it with a thing except a polyacetal pen (tip R0.8 mm or more) or a finger, especially those with hard or sharp tips such as a ball point pen or a mechanical pencil.

5. INTERFACE PIN CONNECTION

(1) FPC1 (Interface Signal)

| Pin No. | Symbol | Function |
|---------|--------|---|
| 1 | GND | |
| 2 | GND | |
| 3 | VCC | 3.3 V Power Supply |
| 4 | VCC | 3.3 V Power Supply |
| 5 | R0 | Red data signal(LSB) |
| 6 | R1 | Red data signal |
| 7 | R2 | Red data signal |
| 8 | R3 | Red data signal |
| 9 | R4 | Red data signal |
| 10 | R5 | Red data signal |
| 11 | R6 | Red data signal |
| 12 | R7 | Red data signal(MSB) |
| 13 | G0 | Green data signal(LSB) |
| 14 | G1 | Green data signal |
| 15 | G2 | Green data signal |
| 16 | G3 | Green data signal |
| 17 | G4 | Green data signal |
| 18 | G5 | Green data signal |
| 19 | G6 | Green data signal |
| 20 | G7 | Green data signal(MSB) |
| 21 | B0 | Blue data signal(LSB) |
| 22 | B1 | Blue data signal |
| 23 | B2 | Blue data signal |
| 24 | B3 | Blue data signal |
| 25 | B4 | Blue data signal |
| 26 | B5 | Blue data signal |
| 27 | B6 | Blue data signal |
| 28 | B7 | Blue data signal(MSB) |
| 29 | GND | |
| 30 | DCLK | Clock signal for sampling catch data signal |
| 31 | DISP | Display on/off (High: on, Low: off) |
| 32 | HD | Horizontal sync signal |
| 33 | VD | Vertical sync signal |
| 34 | DENA | Data enable signal (to settle the viewing area) |
| 35 | AVDD | 5.0 V Analog Power Supply |
| 36 | AVDD | 5.0 V Analog Power Supply |
| 37 | NC | This pin should be open. |
| 38 | NC | This pin should be open. |
| 39 | SC | Scan direction control (Low= Reverse, High= Normal) |
| 40 | GND | |
| 41 | GND | |
| 42 | LED_C1 | LED cathode 1 |
| 43 | LED_A1 | LED anode 1 |
| 44 | LED_C2 | LED cathode 2 |
| 45 | LED_A2 | LED anode 2 |

*) Metal frame is connected to signal GND.

(2) FPC 2 (Touch Panel Interface)

| Pin No. | Symbol |
|---------|--------|
| 1 | XL |
| 2 | XL |
| 3 | YU |
| 4 | YU |
| 5 | XR |
| 6 | XR |
| 7 | YD |
| 8 | YD |

(3) Touch Panel

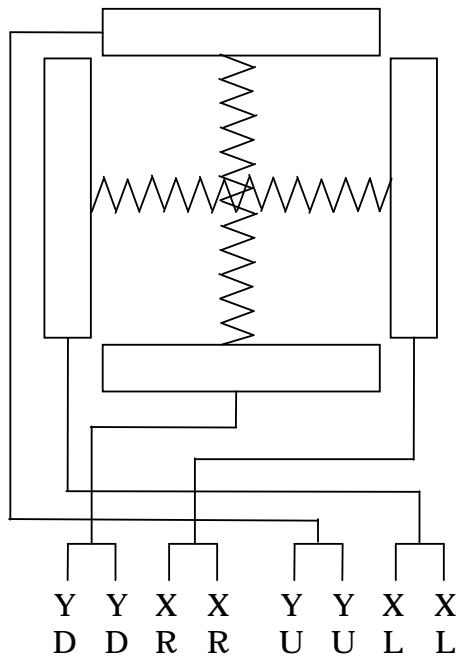

Top View

X: Upper electrode

Y: Lower electrode

6. INTERFACE TIMING

(1) Timing Specifications

| ITEM | | SYMBOL | MIN. | TYP. | MAX. | UNIT |
|----------------------|------------------------|------------------|------|------|------|------------------|
| DCLK | Frequency | f _{CLK} | -- | 33.5 | 45 | MHz |
| | Period | t _{CLK} | 22.2 | 29.9 | -- | ns |
| | Low Width | t _{WCL} | 40% | -- | -- | t _{CLK} |
| | High Width | t _{WCH} | 40% | -- | -- | t _{CLK} |
| DATA(R,G,B), DENA | Set up time | t _{DS} | 4 | -- | -- | ns |
| | Hold time | t _{DH} | 2 | -- | -- | ns |
| DENA | Horizontal Active Time | t _{HA} | 800 | 800 | 800 | t _{CLK} |
| | Horizontal Blank Time | t _{HB} | 164 | 256 | 348 | t _{CLK} |
| | Horizontal Front Porch | t _{HFP} | 48 | 167 | 343 | t _{CLK} |
| | Horizontal Back Porch | t _{HBP} | 5 | 89 | 116 | t _{CLK} |
| | Vertical Active Time | t _{VA} | 480 | 480 | 480 | t _H |
| | Vertical Blank Time | t _{VB} | 35 | 45 | 55 | t _H |
| | Vertical Front Porch | t _{VFP} | 2 | 12 | 22 | t _H |
| | Vertical Back Porch | t _{VBP} | 33 | 33 | 33 | t _H |
| HD | Frequency | f _H | -- | 31.5 | 35 | kHz |
| | Period | t _H | 28.6 | 31.7 | -- | μs |
| | Low Width | t _{WHL} | 1 | -- | -- | t _{CLK} |
| | Set up time | T _{hst} | 6 | -- | -- | ns |
| | Hold time | T _{hhd} | 6 | -- | -- | ns |
| VD | Frequency | f _V | 55 | 60 | 68 | Hz |
| | Period | t _V | 14.7 | 16.7 | 18.2 | ms |
| | Low Width | t _{WVL} | 1 | -- | -- | t _H |
| | Set up time | T _{vst} | 6 | -- | -- | ns |
| | Hold time | T _{vhd} | 6 | -- | -- | ns |

[Note]

- 1) DATA is latched at fall edge of DCLK in this specification.
- 2) Polarities of HD and VD are negative in this specification.
- 3) DENA (Data Enable) should always be positive polarity as shown in the timing specification.
- 4) DCLK should appear during all invalid period, and HD should appear during invalid period of frame cycle.
- 5) Please satisfy following condition.

$$t_{VBn} = t_{VBn-1}$$

(2) Timing Chart

a. Pixel Timing Chart

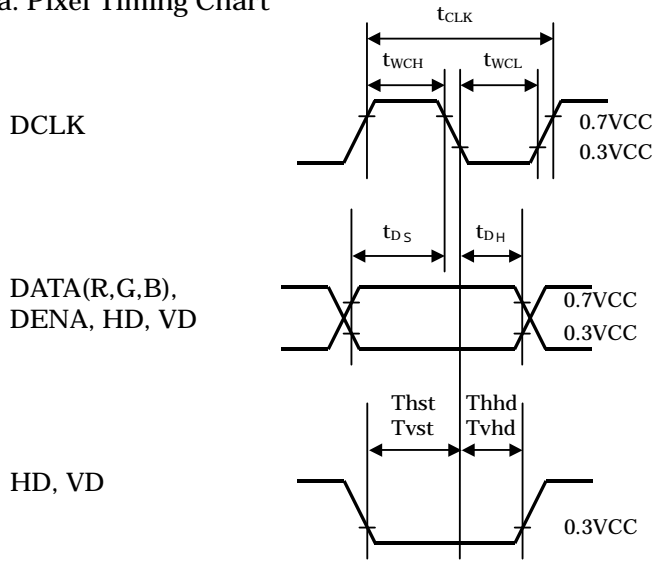

b. Horizontal Timing Chart

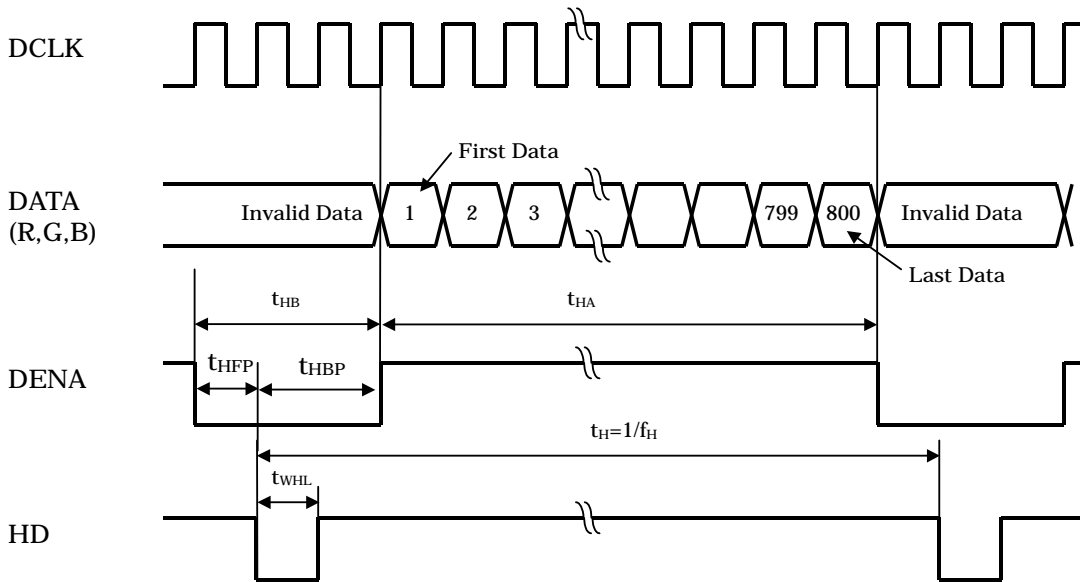

c. Vertical Timing Chart

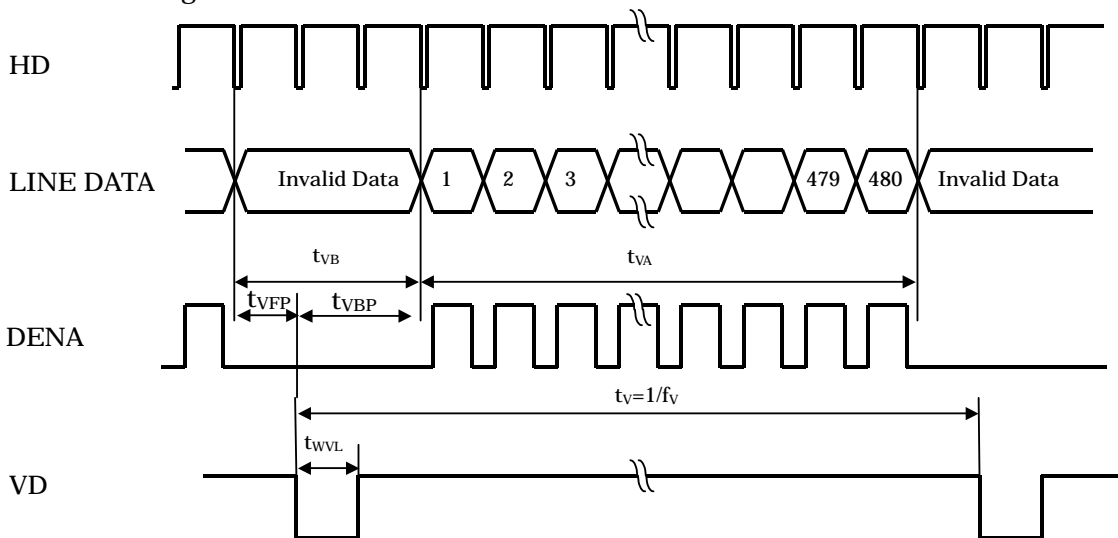

(3) Color Data Assignment

| COLOR | | INPUT DATA | | | | | | | | | | | | | | | | | | | | | | | | | | | | | |
|----------------|------------|------------|----|----|----|----|----|----|----|--------|----|----|----|----|----|----|----|--------|----|----|----|----|----|----|----|-----|--|--|--|--|--|
| | | R DATA | | | | | | | | G DATA | | | | | | | | B DATA | | | | | | | | | | | | | |
| | | R7 | R6 | R5 | R4 | R3 | R2 | R1 | R0 | G7 | G6 | G5 | G4 | G3 | G2 | G1 | G0 | B7 | B6 | B5 | B4 | B3 | B2 | B1 | B0 | | | | | | |
| | | MSB | | | | | | | | LSB | | | | | | | | MSB | | | | | | | | LSB | | | | | |
| BASIC COLOR | BLACK | 0 | 0 | 0 | 0 | 0 | 0 | 0 | 0 | 0 | 0 | 0 | 0 | 0 | 0 | 0 | 0 | 0 | 0 | 0 | 0 | 0 | 0 | 0 | 0 | | | | | | |
| | RED(255) | 1 | 1 | 1 | 1 | 1 | 1 | 1 | 1 | 0 | 0 | 0 | 0 | 0 | 0 | 0 | 0 | 0 | 0 | 0 | 0 | 0 | 0 | 0 | 0 | | | | | | |
| | GREEN(255) | 0 | 0 | 0 | 0 | 0 | 0 | 0 | 0 | 1 | 1 | 1 | 1 | 1 | 1 | 1 | 1 | 0 | 0 | 0 | 0 | 0 | 0 | 0 | 0 | | | | | | |
| | BLUE(255) | 0 | 0 | 0 | 0 | 0 | 0 | 0 | 0 | 0 | 0 | 0 | 0 | 0 | 0 | 0 | 0 | 1 | 1 | 1 | 1 | 1 | 1 | 1 | 1 | | | | | | |
| | CYAN | 0 | 0 | 0 | 0 | 0 | 0 | 0 | 0 | 1 | 1 | 1 | 1 | 1 | 1 | 1 | 1 | 1 | 1 | 1 | 1 | 1 | 1 | 1 | 1 | | | | | | |
| | MAGENTA | 1 | 1 | 1 | 1 | 1 | 1 | 1 | 1 | 0 | 0 | 0 | 0 | 0 | 0 | 0 | 0 | 1 | 1 | 1 | 1 | 1 | 1 | 1 | 1 | | | | | | |
| | YELLOW | 1 | 1 | 1 | 1 | 1 | 1 | 1 | 1 | 1 | 1 | 1 | 1 | 1 | 1 | 1 | 1 | 0 | 0 | 0 | 0 | 0 | 0 | 0 | 0 | | | | | | |
| | WHITE | 1 | 1 | 1 | 1 | 1 | 1 | 1 | 1 | 1 | 1 | 1 | 1 | 1 | 1 | 1 | 1 | 1 | 1 | 1 | 1 | 1 | 1 | 1 | 1 | | | | | | |
| RED | RED(1) | 0 | 0 | 0 | 0 | 0 | 0 | 0 | 1 | 0 | 0 | 0 | 0 | 0 | 0 | 0 | 0 | 0 | 0 | 0 | 0 | 0 | 0 | 0 | 0 | | | | | | |
| | RED(2) | 0 | 0 | 0 | 0 | 0 | 0 | 1 | 0 | 0 | 0 | 0 | 0 | 0 | 0 | 0 | 0 | 0 | 0 | 0 | 0 | 0 | 0 | 0 | 0 | | | | | | |
| | | | | | | | | | | | | | | | | | | | | | | | | | | | | | | | |
| | | | | | | | | | | | | | | | | | | | | | | | | | | | | | | | |
| | RED(255) | 1 | 1 | 1 | 1 | 1 | 1 | 1 | 1 | 0 | 0 | 0 | 0 | 0 | 0 | 0 | 0 | 0 | 0 | 0 | 0 | 0 | 0 | 0 | 0 | | | | | | |
| GREEN | GREEN(1) | 0 | 0 | 0 | 0 | 0 | 0 | 0 | 0 | 0 | 0 | 0 | 0 | 0 | 0 | 0 | 1 | 0 | 0 | 0 | 0 | 0 | 0 | 0 | 0 | | | | | | |
| | GREEN(2) | 0 | 0 | 0 | 0 | 0 | 0 | 0 | 0 | 0 | 0 | 0 | 0 | 0 | 0 | 1 | 0 | 0 | 0 | 0 | 0 | 0 | 0 | 0 | 0 | | | | | | |
| | | | | | | | | | | | | | | | | | | | | | | | | | | | | | | | |
| | | | | | | | | | | | | | | | | | | | | | | | | | | | | | | | |
| | GREEN(255) | 0 | 0 | 0 | 0 | 0 | 0 | 0 | 0 | 1 | 1 | 1 | 1 | 1 | 1 | 1 | 1 | 0 | 0 | 0 | 0 | 0 | 0 | 0 | 0 | | | | | | |
| BLUE | BLUE(1) | 0 | 0 | 0 | 0 | 0 | 0 | 0 | 0 | 0 | 0 | 0 | 0 | 0 | 0 | 0 | 0 | 0 | 0 | 0 | 0 | 0 | 0 | 0 | 1 | | | | | | |
| | BLUE(2) | 0 | 0 | 0 | 0 | 0 | 0 | 0 | 0 | 0 | 0 | 0 | 0 | 0 | 0 | 0 | 0 | 0 | 0 | 0 | 0 | 0 | 0 | 1 | 0 | | | | | | |
| | | | | | | | | | | | | | | | | | | | | | | | | | | | | | | | |
| | | | | | | | | | | | | | | | | | | | | | | | | | | | | | | | |
| | BLUE(255) | 0 | 0 | 0 | 0 | 0 | 0 | 0 | 0 | 0 | 0 | 0 | 0 | 0 | 0 | 0 | 0 | 1 | 1 | 1 | 1 | 1 | 1 | 1 | 1 | | | | | | |

[Note]

1) Definition of gray scale

Color (n) --- n indicates gray scale level.

Higher n means brighter level.

2) Data

1:High, 0: Low

(4) Display Position and Scan Direction

D(X,Y) shows the data number of input signal

SC: High

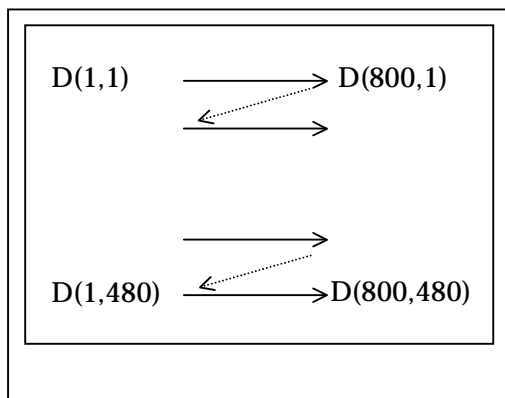

SC: Low

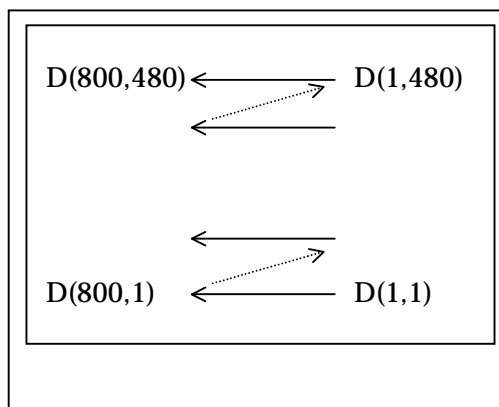

7. BLOCK DIAGRAM

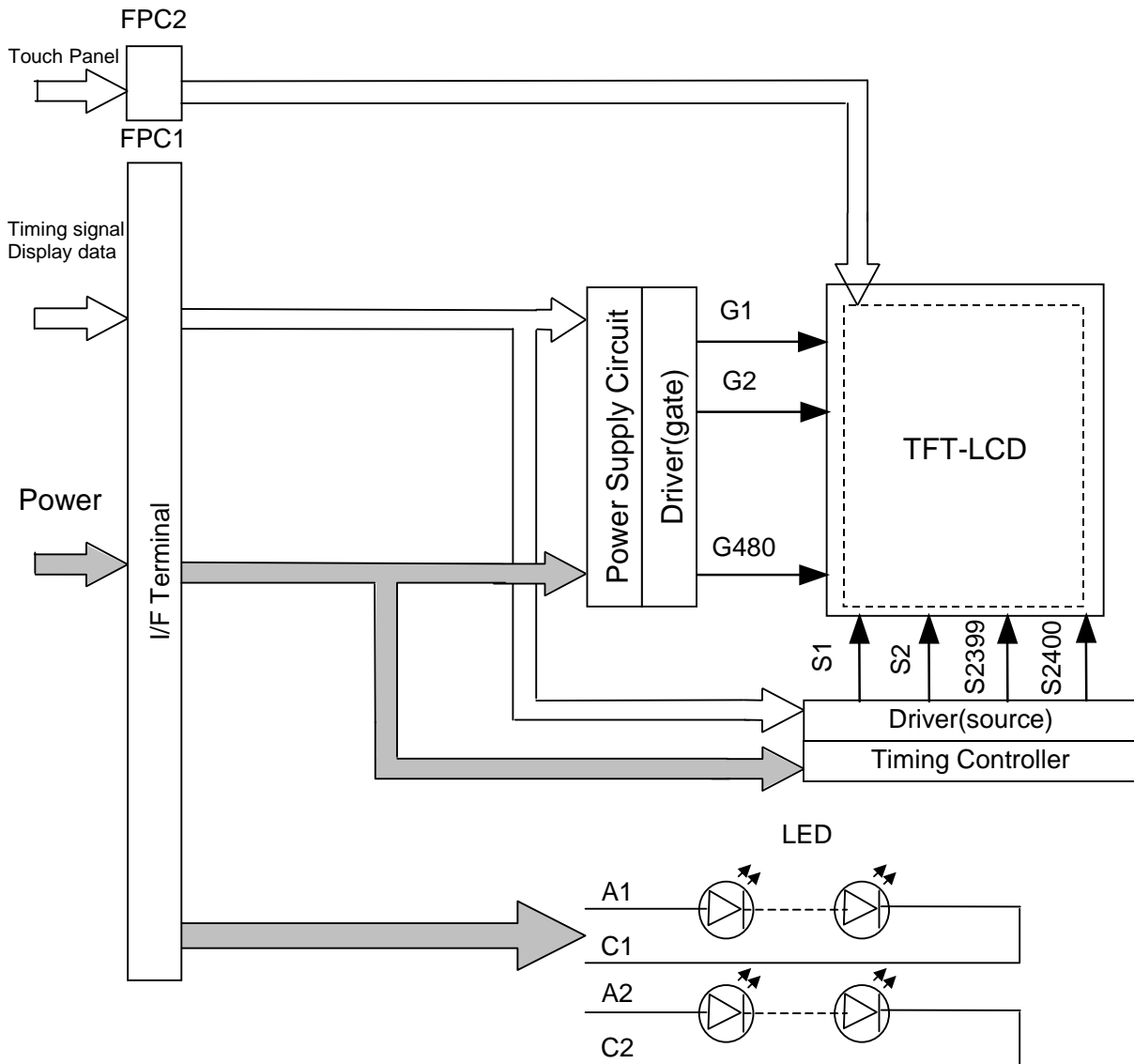

8. MECHANICAL SPECIFICATIONS

(1) Outline Dimensions

TOUCH SCREEN PANEL
PIN CONNECTION (FPC2)

| PIN No. | XL | YU | XR | YD |
|---------|----|----|----|----|
| 1 | | | | |
| 2 | | | | |
| 3 | | | | |
| 4 | | | | |
| 5 | | | | |
| 6 | | | | |
| 7 | | | | |
| 8 | | | | |

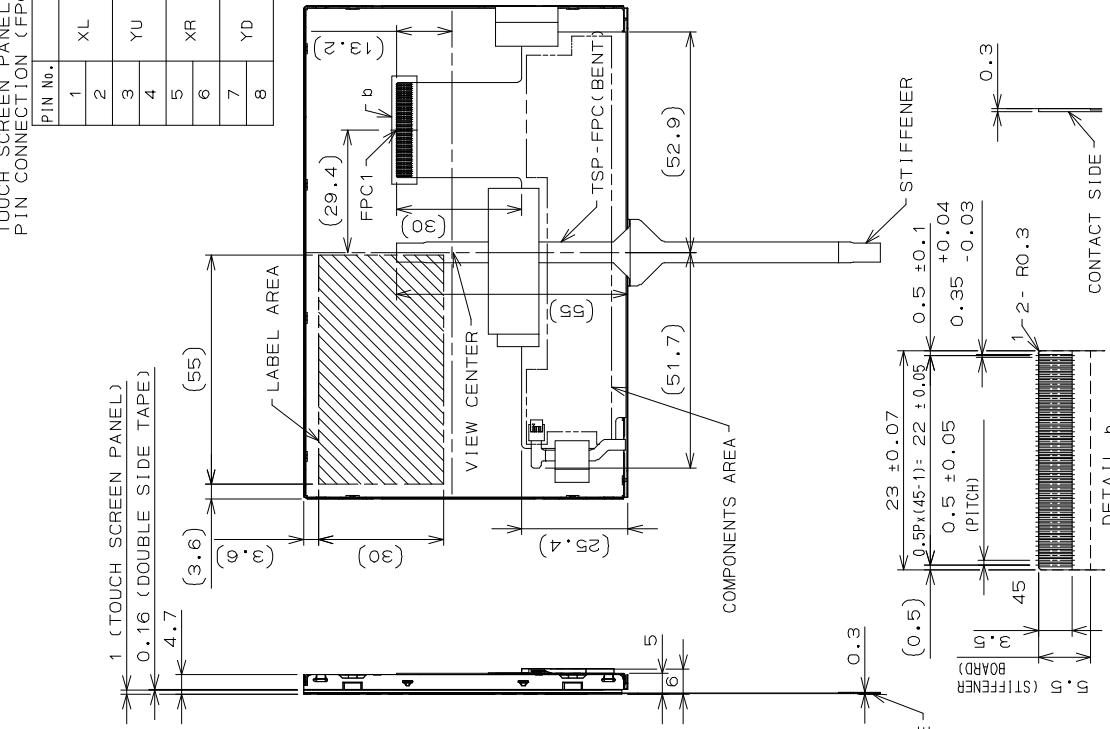

AA050MC01--T1
 1) Tolerance is $\pm 0.5\text{mm}$ unless noted.
 2) Third angle projection

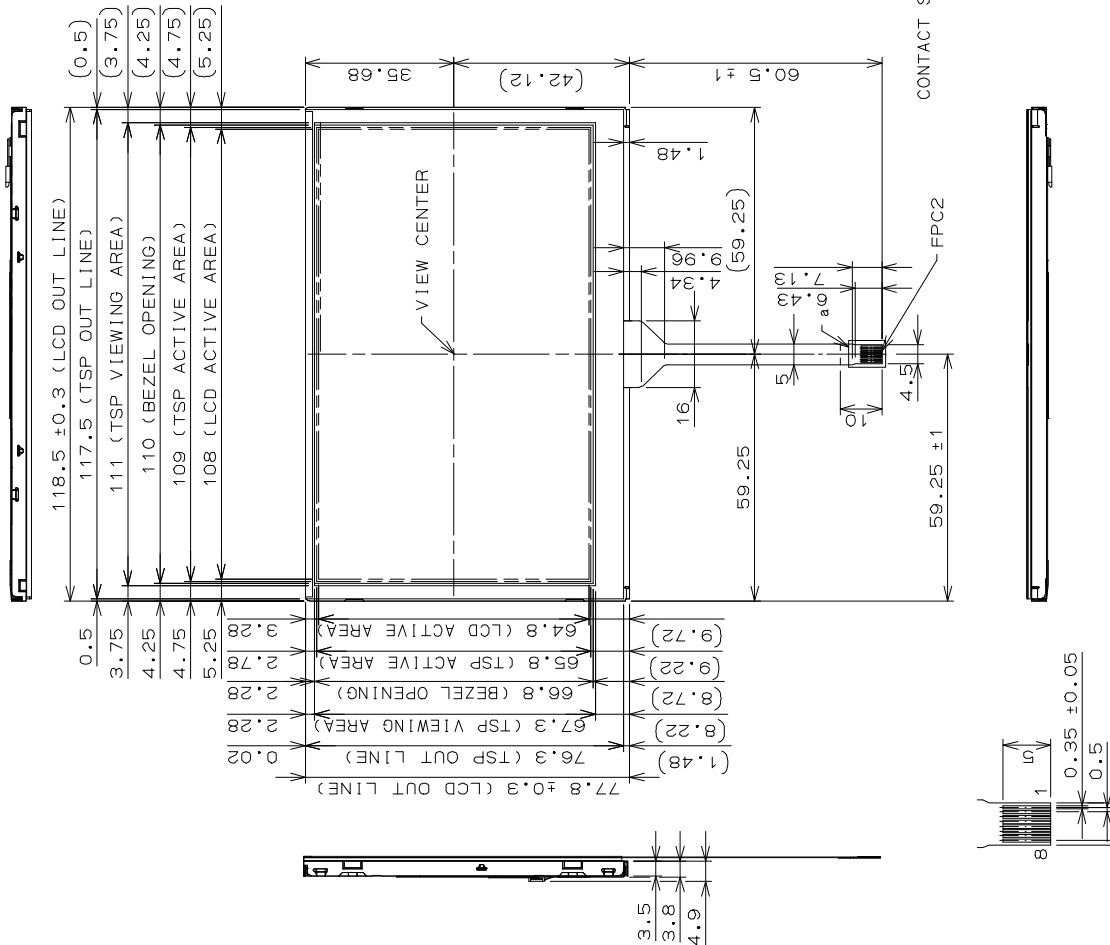

DETAIL a

(Unit:mm)

(2) Touch Panel

a. Mechanical Characteristics

| ITEM | MIN. | TYP. | MAX. | UNIT | Remarks | |
|------------------|--------------------|---------------|------|------|--------------------------|-----|
| Activation Force | 0.05 | -- | 0.8 | N | *1) | |
| Durability | Surface Scratching | Write 100,000 | -- | -- | characters | *2) |
| | Surface Pitting | 10,000,000 | -- | -- | touches | *3) |
| Surface Hardness | 3 | -- | -- | H | JIS K5400, ASTM D3363 | |

*1) Stylus pen Input: R4.0 mm silicon pen

*2) Measurement for Surface area

-Input size 10 × 10 mm

-Input Character A to Z /minute

-Force: 2.45 N

-Stylus: R0.8 mm polyacetal tip

*3) Pit 10,000,000 hits on the Film with a R4.0 mm silicon pen

-Force: 3 N

-Speed: 2 hits/sec

b. Design Guide

-Avoid the design that Front-case overlap and press on the active area of the touch-panel.

-Give enough gap (over 0.5 mm at compressed) between the front case and touch-panel to protect wrong operating.

-Use a buffer material (Gasket) between the touch-panel and Front-case to protect damage and wrong operating.

-Avoid the design that buffer material overlap and press on the inside of touch-panel viewing area.

-The flexible tail section should be designed to avoid stress from the front case and/or avoid any bending stress to root of flexible tail section.

-Please avoid any strong forces, such as pen input in the area between display area and insulated area (distance: >2mm), because it may cause damage to the film.

-When you handle the product, hold the product by its body. Do not hold by the FPC.

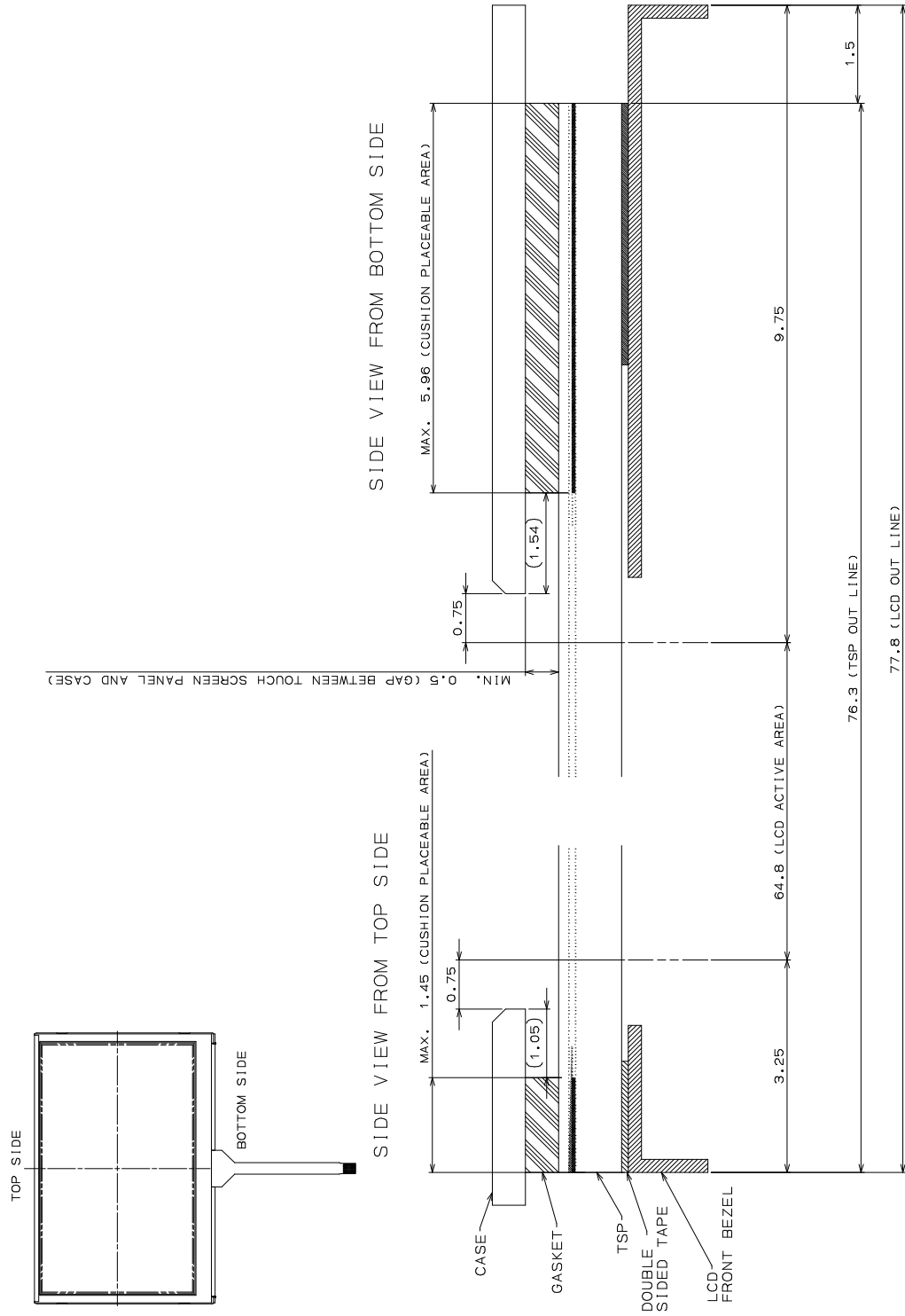

FIG.1

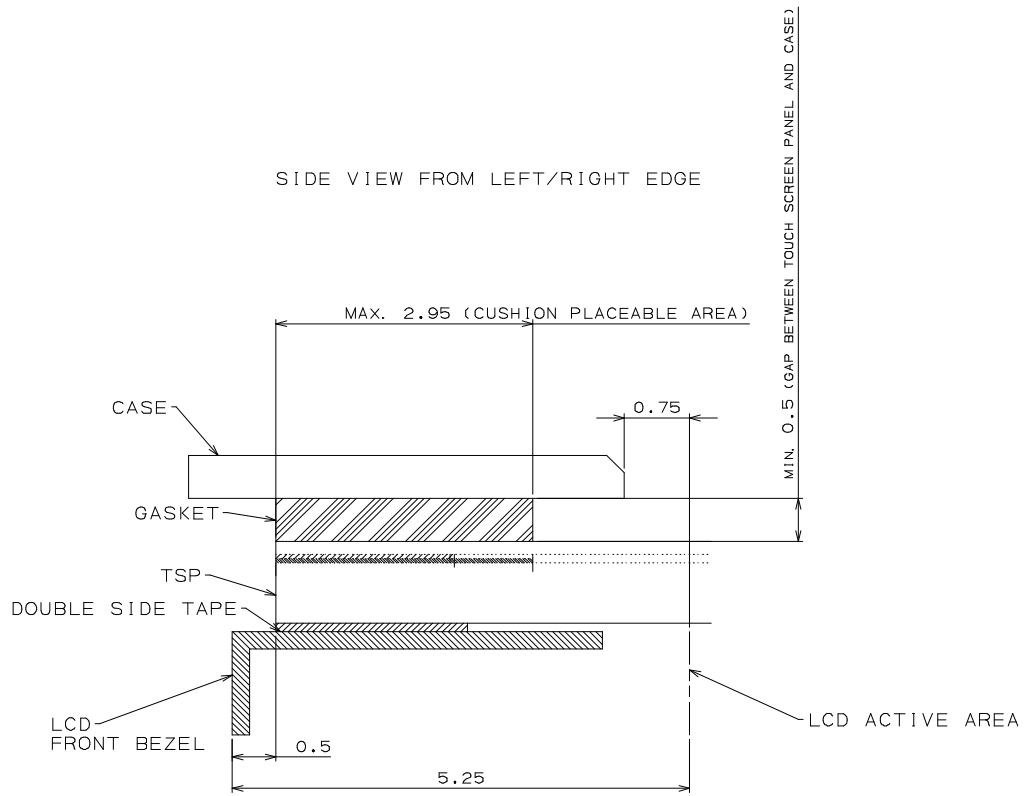

FIG.2

9. OPTICAL CHARACTERISTICS

Ta=25°C, VCC=3.3 V, AVDD=5.0V, Input Signals: Typ. values shown in Section 6

| ITEM | SYMBOL | CONDITION | MIN. | TYP. | MAX. | UNIT | Remarks | |
|----------------------|-------------|--------------------------------------|--------------------------------------|--------|--------|-------------------|-----------|--------|
| Contrast Ratio | CR | $\theta_V=0^\circ, \theta_H=0^\circ$ | 390 | 600 | -- | -- | *1)*2)*5) | |
| Luminance | Lw | $\theta_V=0^\circ, \theta_H=0^\circ$ | 200 | 250 | -- | cd/m ² | *1)*5) | |
| Luminance Uniformity | ΔLw | $\theta_V=0^\circ, \theta_H=0^\circ$ | -- | -- | 30 | % | *1)*3)*5) | |
| Response Time | tr | $\theta_V=0^\circ, \theta_H=0^\circ$ | -- | 25 | -- | ms | *1)*4)*5) | |
| | tf | $\theta_V=0^\circ, \theta_H=0^\circ$ | -- | 25 | -- | ms | *1)*4)*5) | |
| Viewing Angle | Horizontal | θ_H | CR \geq 10 | -70~70 | -85~85 | -- | ° | *1)*5) |
| | Vertical | θ_V | | -70~70 | -85~85 | -- | ° | *1)*5) |
| Image Sticking | tis | 2 h | -- | -- | 2 | s | *6) | |
| Color Coordinates | Red | Rx | $\theta_V=0^\circ, \theta_H=0^\circ$ | 0.537 | 0.587 | 0.637 | -- | *1)*5) |
| | | Ry | | 0.312 | 0.362 | 0.412 | | |
| | Green | Gx | | 0.292 | 0.342 | 0.392 | | |
| | | Gy | | 0.532 | 0.582 | 0.632 | | |
| | Blue | Bx | | 0.103 | 0.153 | 0.203 | | |
| | | By | | 0.077 | 0.127 | 0.177 | | |
| | White | Wx | | 0.266 | 0.316 | 0.366 | | |
| | | Wy | | 0.294 | 0.344 | 0.394 | | |

[Note]

These items are measured using EZContrast (ELDIM) for viewing angle and CS2000 (Minolta) or equivalent equipment for others under the dark room condition (no ambient light) after more than 30 minutes from turning on the backlight unless noted.

Condition: IF=20 mA

Measurement method for luminance and color coordinates is as follows.

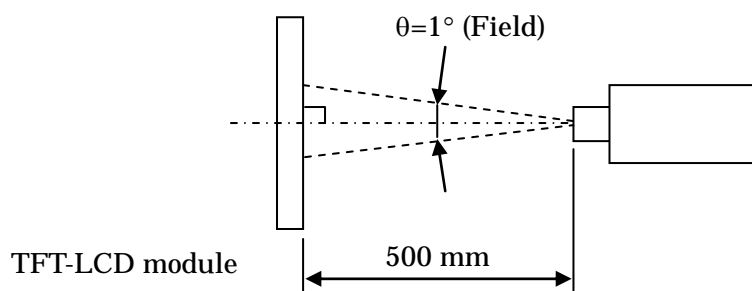

The luminance is measured according to FLAT PANEL DISPLAY MEASUREMENTS STANDARD (VESA Standard).

*1) Measurement Point

Contrast Ratio, Luminance, Response Time, Viewing Angle, Color Coordinates: Display Center
 Luminance Uniformity: point 1~5 shown in a figure below

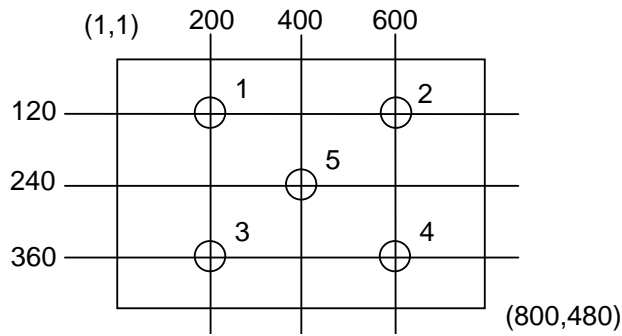

*2) Definition of Contrast Ratio

$CR = \text{Luminance with all white pixels} / \text{Luminance with all black pixels}$

*3) Definition of Luminance Uniformity

$\Delta Lw = [Lw(\text{MAX}) / Lw(\text{MIN}) - 1] \times 100$

*4) Definition of Response Time

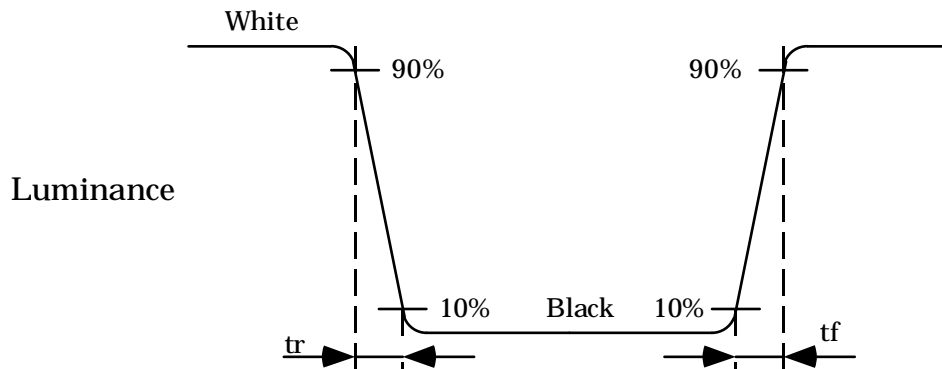

*5) Definition of Viewing Angle (θ_v , θ_H)

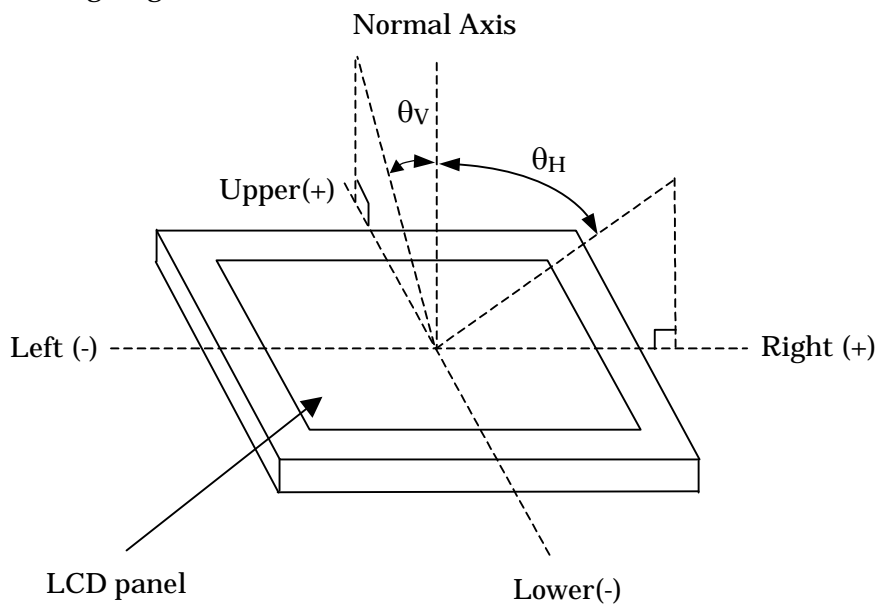

***6) Image Sticking**

Continuously display the test pattern shown in the figure below for two-hours. Then display a completely white screen. The previous image shall not persist more than two seconds at 25°C.

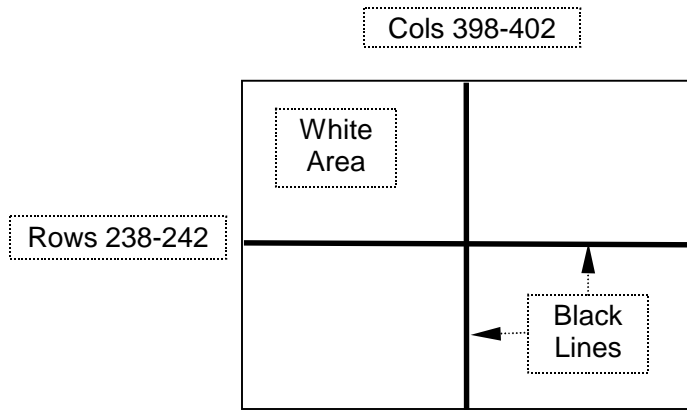

TEST PATTERN FOR IMAGE STICKING TEST

10. RELIABILITY TEST CONDITION

(1) Temperature and Humidity

| ITEM | CONDITIONS |
|---|---|
| HIGH TEMPERATURE HIGH HUMIDITY OPERATION | 40°C, 90%RH, 240 h (No condensation) |
| HIGH TEMPERATURE OPERATION | 60°C, 240 h |
| LOW TEMPERATURE OPERATION | -20°C, 240 h |
| HIGH TEMPERATURE STORAGE | 80°C, 240 h |
| LOW TEMPERATURE STORAGE | -30°C, 240 h |
| THERMAL SHOCK (NON-OPERATION) | -30°C (1h) ~ 80°C(1h) 100 cycles |

(2) Shock & Vibration

| ITEM | CONDITIONS |
|------------------------------|--|
| SHOCK (NON-OPERATION) | Shock level: 1470m/s ² (150G) Waveform: half sinusoidal wave, 2ms Number of shocks: one shock input in each direction of three mutually perpendicular axis for a total of six shock inputs |
| VIBRATION (NON-OPERATION) | Vibration level: 9.8m/s ² (1.0G) Waveform: sinusoidal Frequency range: 5 to 500Hz Frequency sweep rate: 0.5 octave /min Duration: one sweep from 5 to 500 Hz in each of three mutually perpendicular axis(each x,y,z axis: 1 hour, total 3 hours) |

(3) ESD Test

| ITEM | CONDITIONS |
|---|---|
| CONTACT DISCHARGE (OPERATION) | 150pF, 330Ω, ±8kV, 10 times at 1 sec interval |
| SIGNAL PIN DISCHARGE (NON-OPERATION) | 200pF, 0Ω, ±200V, 10 times at 1 sec interval |

(4) Judgment standard

The judgment of the above tests should be made as follow:

Pass: Normal display image, no damage of the display function. (ex. no line defect)

Partial transformation of the module parts should be ignored.

Fail: No display image, damage of the display function. (ex. line defect)

11. OTHER FEATURE

This LCD module complies with RoHS*) directive.

*) RoHS: Restriction of the use of certain hazardous substances in electrical and electronic equipment

12. HANDLING PRECAUTIONS FOR TFT-LCD MODULE

Please pay attention to the followings in handling TFT-LCD products;

(1) ASSEMBLY PRECAUTION

- a. Please do not bend or wrench the LCD module in assembling. Please do not drop, bend or twist the LCD module in handling.
- b. Please design display housing in accordance with the following guide lines.
 - (a) Housing case must be designed carefully so as not to put stresses on LCD and not to wrench module.
 - (b) Under high temperature environment, performance and life time of LED may heavily shorten. When you design with our LCD product, please consider radiating heat and ventilation for good heat management.
 - (c) Keep sufficient clearance between LCD module back surface and housing when the LCD module is mounted. Approximately 1.0mm of the clearance in the design is recommended taking into account the tolerance of LCD module thickness and mounting structure height on the housing.
 - (d) When some parts, such as, FPC cable and ferrite plate, are installed underneath the LCD module, still sufficient clearance is required, such as 0.5mm. This clearance is, especially, to be reconsidered when the additional parts are implemented for EMI countermeasure.
 - (e) Design the LED driver location and connector position carefully so as not to give stress to LED backlight cable and flexible tail.
 - (f) Keep sufficient clearance between LCD module and the others parts, such as inverter and speaker so as not to interfere the LCD module. Approximately 1.0 mm of the clearance in the design is recommended.
 - (g) To avoid local elevation/decrease of temperature, considering location of heating element, heat release, thermal design should be done.
- c. Please do not push or scratch touch panel surface with anything hard. And do not soil LCD panel surface by touching with bare hands.
- d. Please wipe off touch panel surface with absorbent cotton or soft cloth in case of it being soiled.
- e. Touch panel glass edge is not rounded. Please take care in handling to avoid injury.
- f. Please do not take a LCD module to pieces and reconstruct it. Resolving and reconstructing modules may cause them not to work well.
- g. Please do not touch metal frames with bare hands and soiled gloves. A color change of the metal frames can happen during a long preservation of soiled LCD modules.
- h. Please handle metal frame carefully because edge of metal frame is very sharp.
- i. Please connect the metal frame of LCD module to GND in order to minimize the effect of external noise and EMI.
- j. Be sure to connect the cables and the connectors correctly.

(2) OPERATING PRECAUTIONS

- a. Please be sure to turn off the power supply before connecting and disconnecting signal input cable.

- b. Please do not change variable resistance settings in LCD module. They are adjusted to the most suitable value. If they are changed, it might happen LCD does not satisfy the characteristics specification.
- c. The interface signal speed is very high. Please pay attention to transmission line design and other high speed signal precautions to satisfy signal specification.
- d. Condensation might happen on the surface and inside of LCD module in case of sudden change of ambient temperature. Do not use touch panel when there is condensation. It could cause touch panel failure.
- e. Please pay attention not to display the same pattern for very long time. Image sticking might happen on LCD. Although image sticking may disappear as the operation time proceeds, screen saver function is recommended not to cause image sticking.
- f. Please obey the same safe instructions as ones being prepared for ordinary electronic products.

(3) PRECAUTIONS WITH ELECTROSTATICS

- a. This LCD module use CMOS-IC on circuit board and TFT-LCD panel, and so it is easy to be affected by electrostatics. Please be careful with electrostatics by the way of your body connecting to the ground and so on.
- b. Please remove protection film very slowly from the surface of touch panel to prevent from electrostatics occurrence.

(4) STORAGE PRECAUTIONS

LCD should be stored in the room temperature environment with normal humidity. The LCD inventory should be processed by first-in first-out method.

(5) SAFETY PRECAUTIONS

- a. When you waste damaged or unnecessary LCDs, it is recommended to crush LCDs into pieces and wash them off with solvents such as acetone and ethanol, which should later be burned.
- b. If any liquid leaks out of a damaged glass cell and comes in contact with the hands, wash off thoroughly with soap and water.
- c. Be sure to turn off the power supply when inserting or disconnecting the LED backlight cable.
- d. LED driver should be designed carefully to limit or stop its function when over current is detected on the LED.

(6) OTHERS

- a. A strong incident light into LCD panel may cause deterioration to touch panel, polarizer film, color filter, and other materials, which will degrade the quality and performance of display. Please do not expose LCD module under strong Ultraviolet rays for a long time. If using under direct sunlight condition, please test the reliability and performance completely.
- b. For the packaging box handling, please see and obey with the packaging specification datasheet.

Mouser Electronics

Authorized Distributor

Click to View Pricing, Inventory, Delivery & Lifecycle Information:

[Mitsubishi Electric:](#)

[AA050MC01--T1](#)