

THIS DRAWING IS UNPUBLISHED. RELEASED FOR PUBLICATION 20  
 © COPYRIGHT 20 BY - ALL RIGHTS RESERVED.

REVISIONS					
P	LTR	DESCRIPTION	DATE	DWN	APVD
	A	REVISED PER ECR-18-014960	21SEP2018	SS	JL
	A1	REVISED PER ECR-19-008871	13JUN2019	SR	DD
	A2	REVISED PER ECR-19-009651	12JUL2019	SR	DD

1 MATERIALS:  
 HOUSING: PBT  
 DIMMING CONTACTS (QTY. 4): COPPER ALLOY  
 LINE VOLTAGE CONTACTS (QTY. 3): COPPER ALLOY  
 GASKET: VINYL/NITRILE FOAM  
 O-RING: SILICONE RUBBER  
 MEMBRANE VENT: PTFE

2 FINISH:  
 DIMMING CONTACTS: NICKEL UNDERPLATE ENTIRE  
 CONTACT 0.127 µm MIN THICK. SELECTIVE GOLD PLATE CONTACT  
 MATING AREA (MATING FACE SIDE ONLY) 0.76 µm MIN THICK.  
 MATTE TIN PLATE TAB ON BOTH SIDES 0.30 µm MIN THICK.  
 LINE VOLTAGE CONTACTS: MATTE TIN PLATE

3 MATING INTERFACE PER ANSI C136.41-2013.

4 ADHESIVE BACKED GASKET SUPPLIED BUT NOT INSTALLED.

5 ADDITIONAL COVERS AND SLEEVES OF VARIOUS HEIGHTS ARE AVAILABLE. CONTACT TE CONNECTIVITY FOR MORE OPTIONS.

7. THIS PRODUCT HAS NOT COMPLETED VALIDATION TESTING.

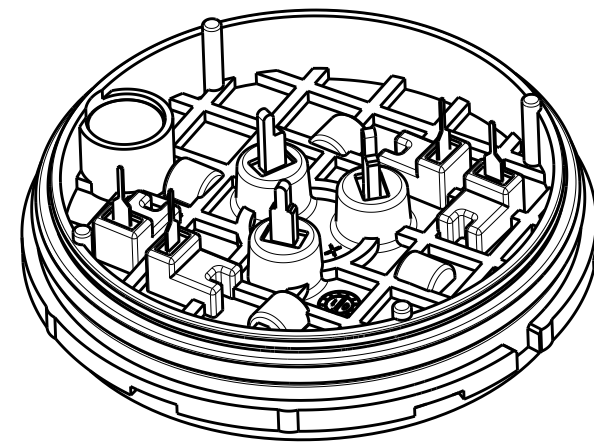

2336396-1 SHOWN

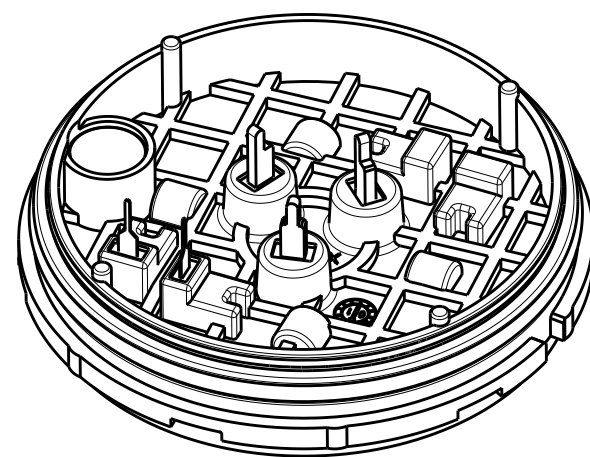

1-2336396-1 SHOWN

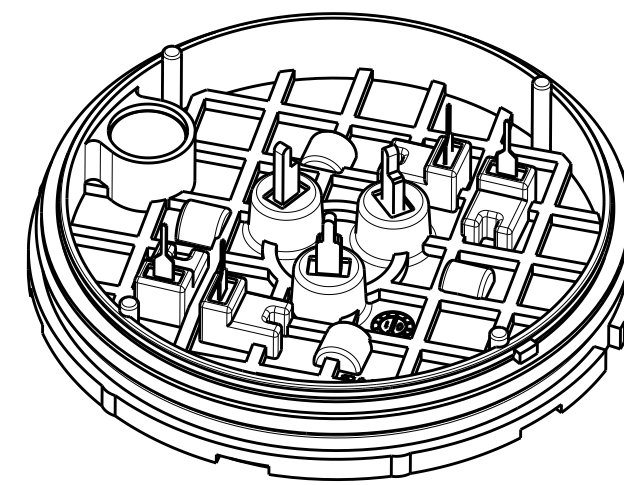

2336396-2 SHOWN

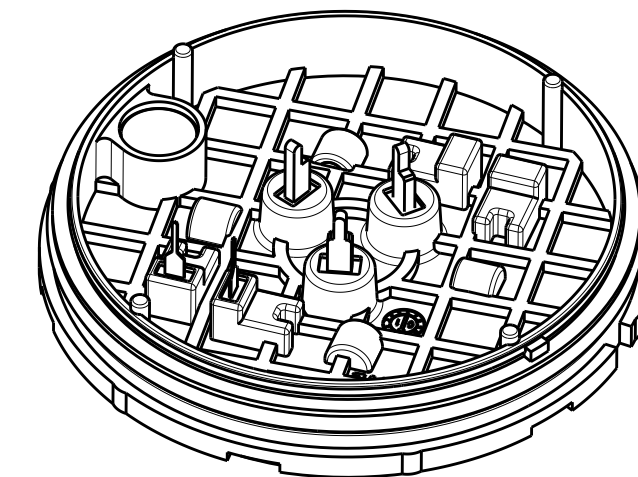

1-2336396-2 SHOWN

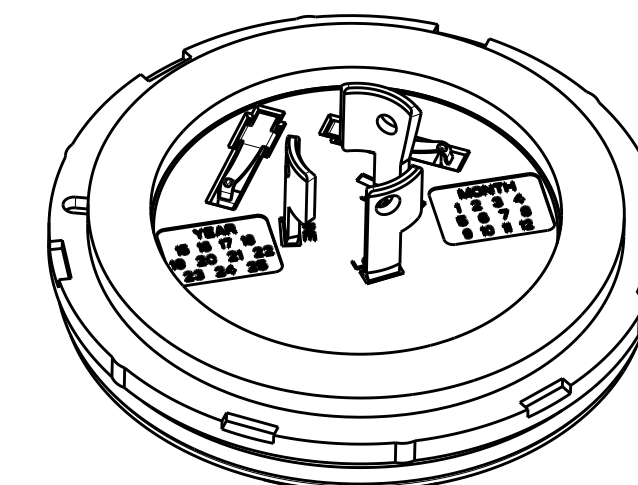
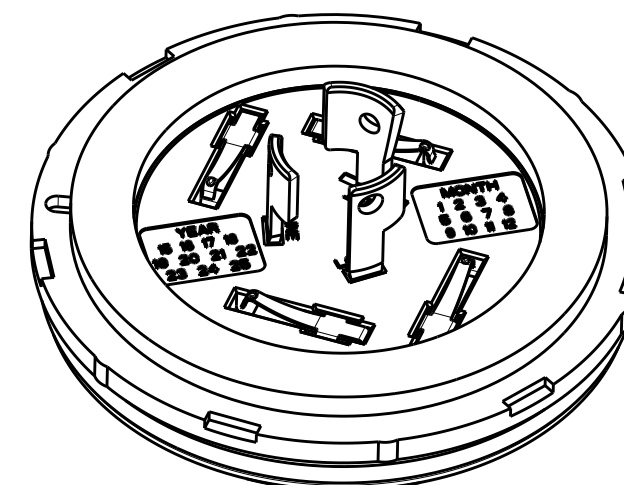
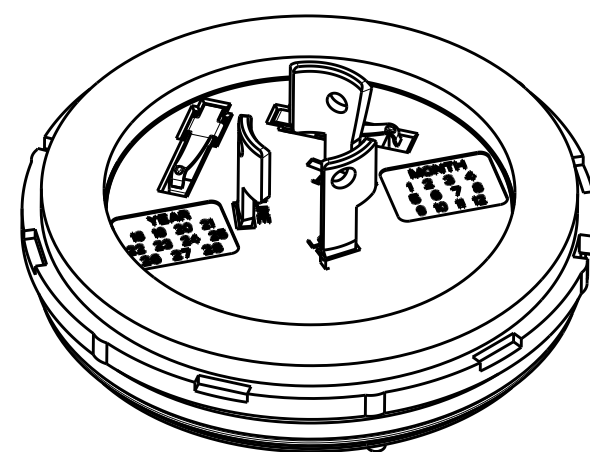
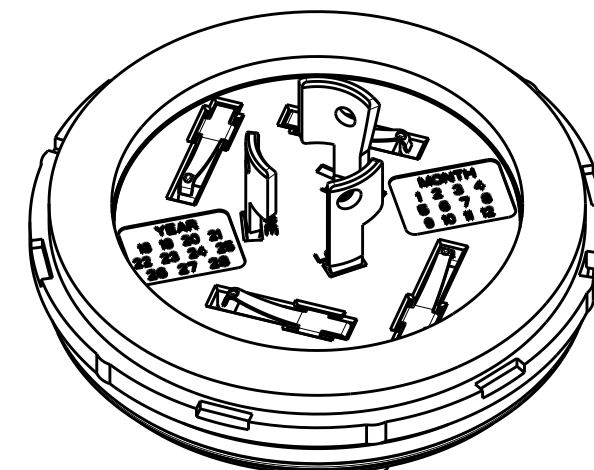

2213996-X	2306130-X	5	13.04	26.20	Ø82.24	Ø78.54	Ø69.80	Ø70.70	Ø72.25	Ø77.53	Ø77.74	Ø81.15	1-2336396-2
2213996-X	2306130-X	7	13.04	26.20	Ø82.24	Ø78.54	Ø69.80	Ø70.70	Ø72.25	Ø77.53	Ø77.74	Ø81.15	2336396-2
2213805-X	2213748-X	5	4.35	27.45	Ø77.00	Ø76.96	Ø64.50	Ø65.00	Ø66.75	Ø71.23	Ø72.00	Ø76.00	1-2336396-1
2213805-X	2213748-X	7	4.35	27.45	Ø77.00	Ø76.96	Ø64.50	Ø65.00	Ø66.75	Ø71.23	Ø72.00	Ø76.00	2336396-1
REPRESENTATIVE SLEEVE P/N 5	REPRESENTATIVE COVER P/N 5	CONTACT POSITIONS	DIM T	DIM S	DIM Y	DIM X	DIM P	DIM N	DIM M MAX WITH SLEEVE	DIM M MAX W/OUT SLEEVE	DIM F	DIM E	PART NO.

THIS DRAWING IS A CONTROLLED DOCUMENT.

DWN J. SHAFFER 03MAY2018  
 CHK M. MOSTOLLER 03MAY2018  
 APVD -

**STE** TE Connectivity

NAME: BASE ASSEMBLY, LIGHT CONTROLLER, SLEEVE COMPATIBLE

PRODUCT SPEC: 108-32125  
 APPLICATION SPEC: 114-32159

SIZE: A2 CAGE CODE: - DRAWING NO: C-2336396 RESTRICTED TO: -

WEIGHT: -

CUSTOMER DRAWING SCALE: 2:1 SHEET: 1 OF 5 REV: A2

THIS DRAWING IS UNPUBLISHED. RELEASED FOR PUBLICATION 20  
 © COPYRIGHT 20 BY - ALL RIGHTS RESERVED.

REVISIONS				
P	LTR	DESCRIPTION	DATE	APVD
-	-	SEE SHEET 1	-	-

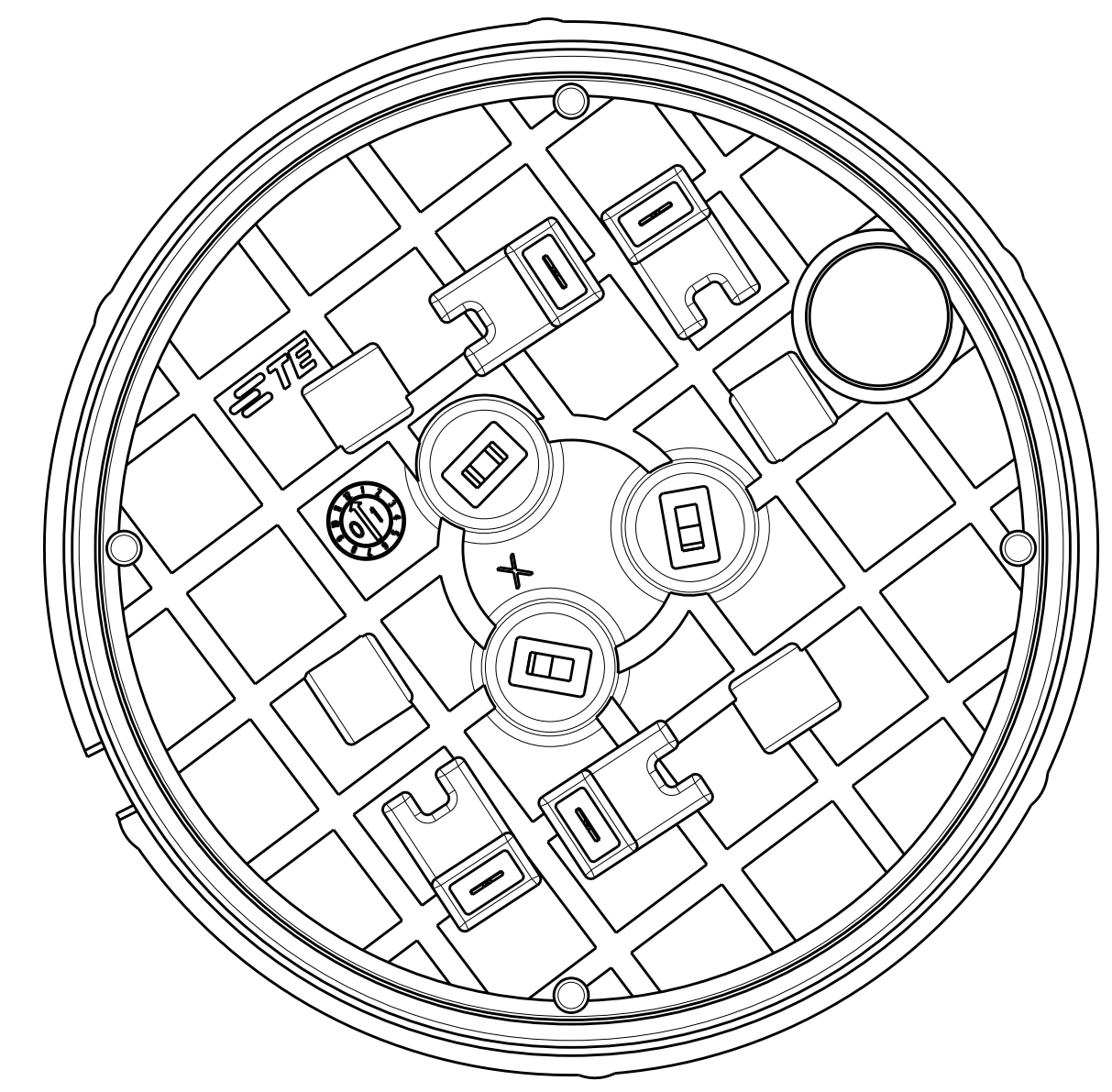
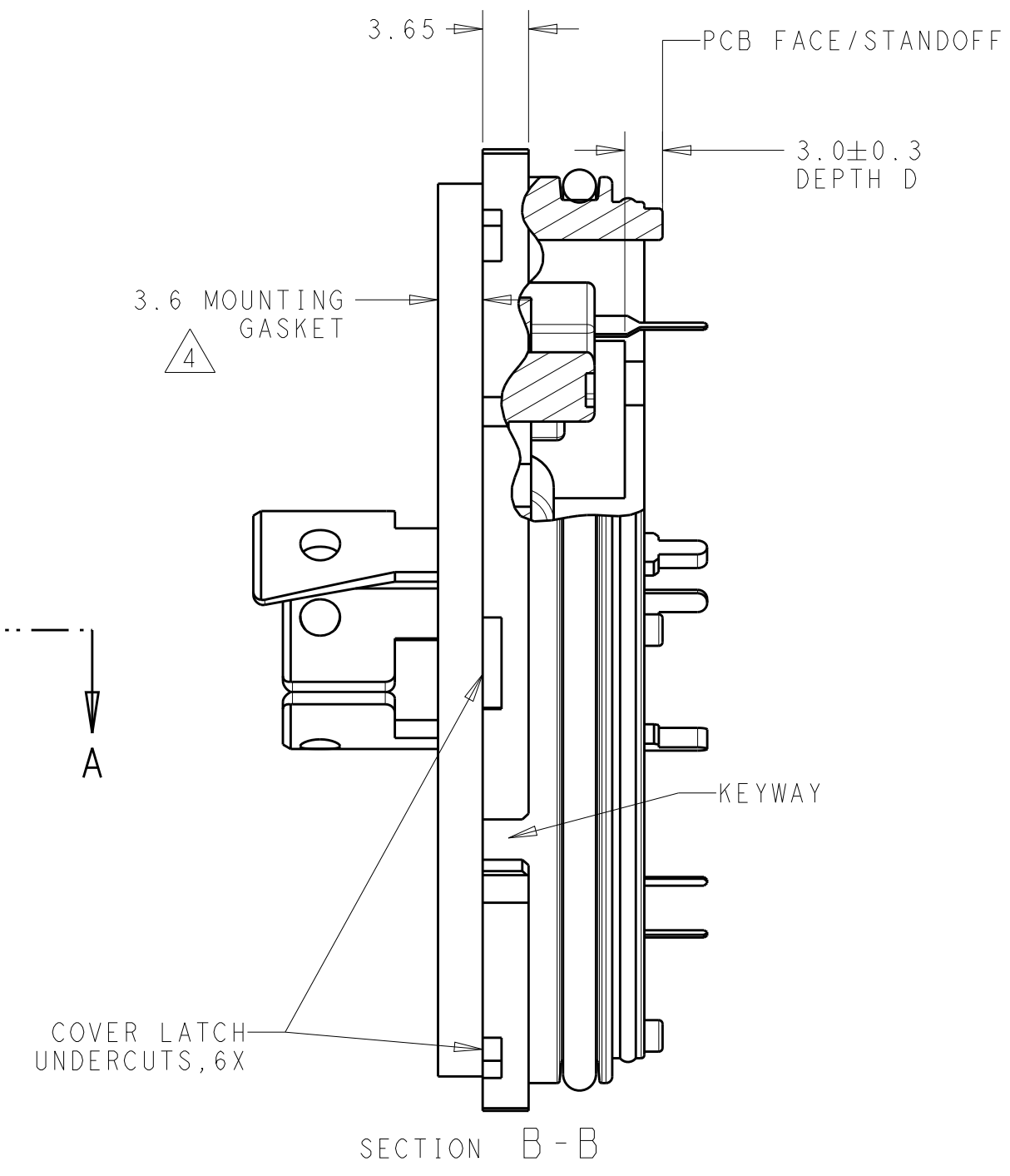
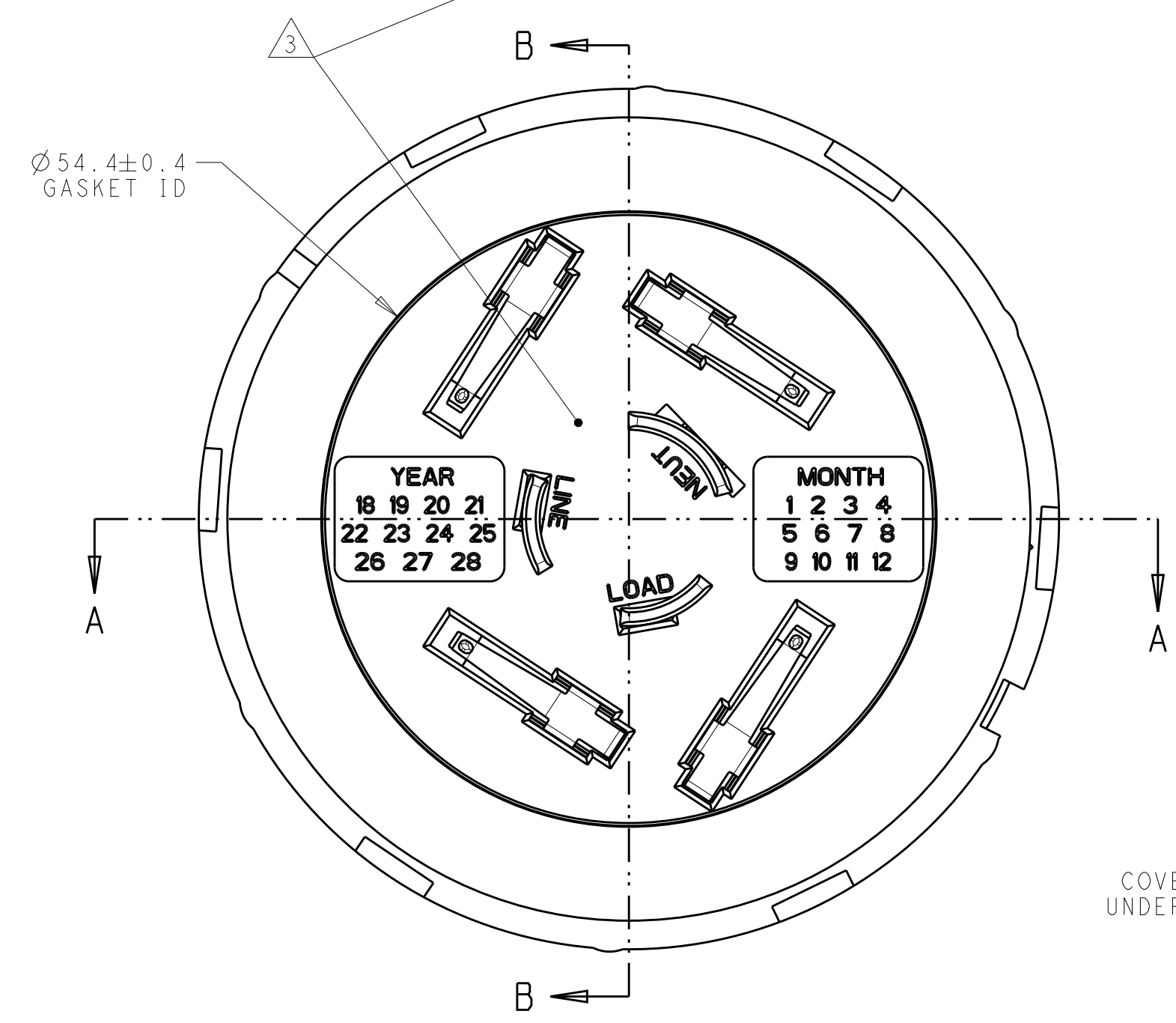
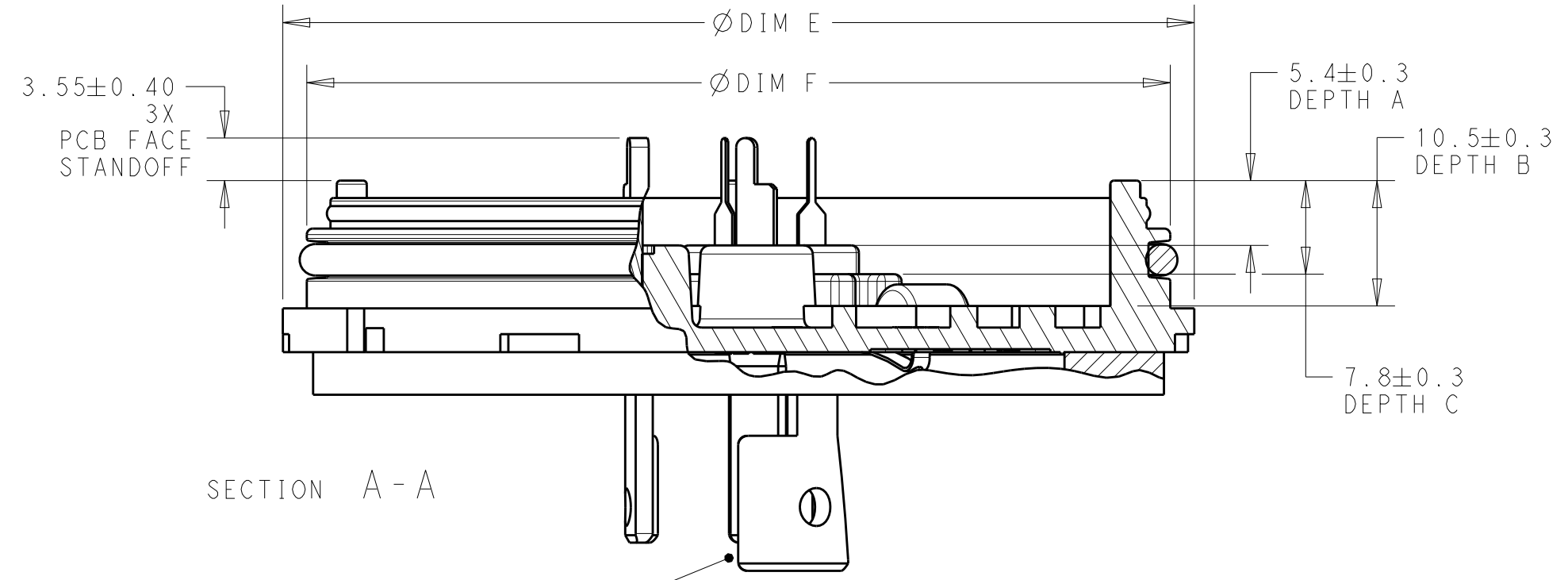

THIS DRAWING IS A CONTROLLED DOCUMENT.		DWN J. SHAFFER 03MAY2018	TE Connectivity	
		CHK M. MOSTOLLER 03MAY2018		
DIMENSIONS: mm		TOLERANCES UNLESS OTHERWISE SPECIFIED: 0 PLC ± 1 PLC ±0.2 2 PLC ±0.13 3 PLC ± 4 PLC ± ANGLES ±3° FINISH -		NAME BASE ASSEMBLY, LIGHT CONTROLLER, SLEEVE COMPATIBLE
MATERIAL -		PRODUCT SPEC 108-32125 APPLICATION SPEC 114-32159 WEIGHT -	SIZE A2	CAGE CODE -
		DRAWING NO C-2336396		RESTRICTED TO -
		CUSTOMER DRAWING		SCALE 2:1 SHEET 2 OF 5 REV A2

THIS DRAWING IS UNPUBLISHED. RELEASED FOR PUBLICATION 20  
 © COPYRIGHT 20 BY - ALL RIGHTS RESERVED.

REVISIONS				
P	LTR	DESCRIPTION	DATE	APVD
-	-	SEE SHEET 1	-	-

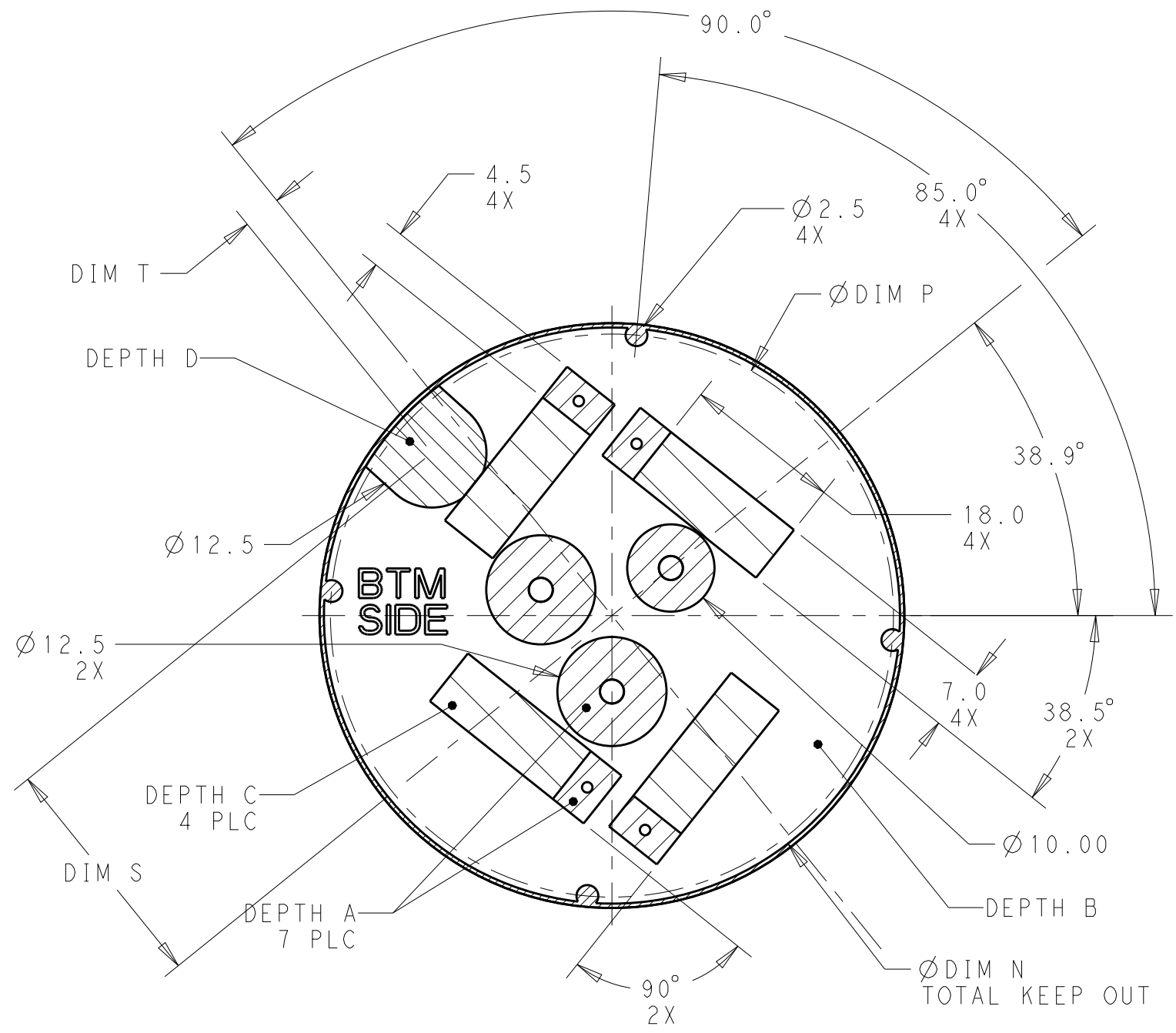

COMPONENT KEEP OUT AREAS  
 2336396-1 AND 2336396-2

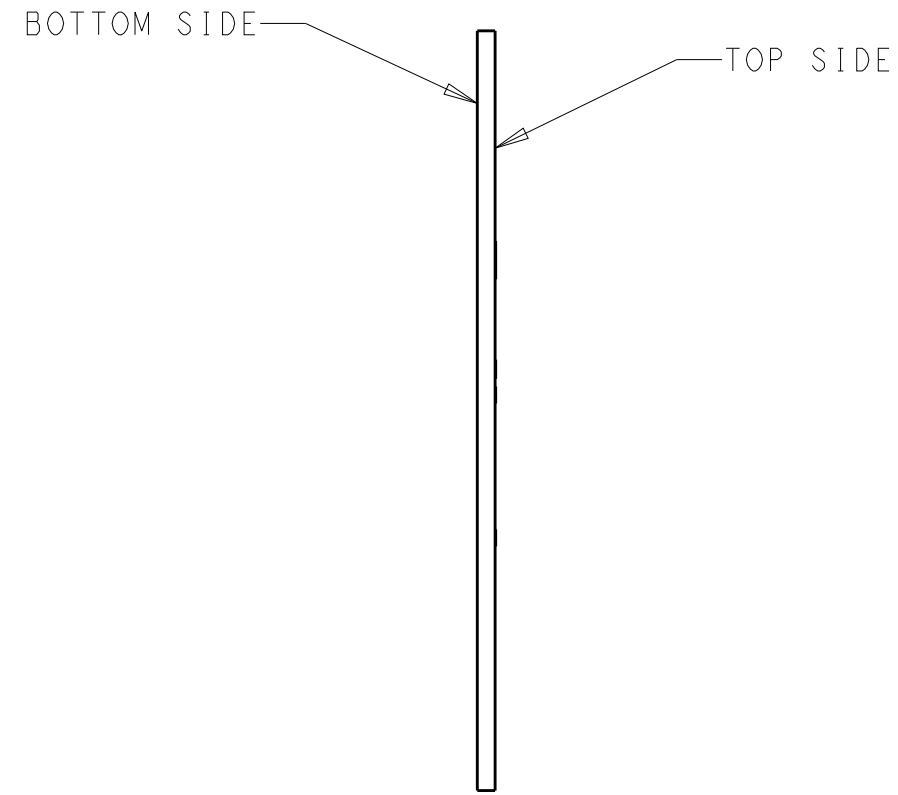

RECOMMENDED PCB  
 SCALE 3:2

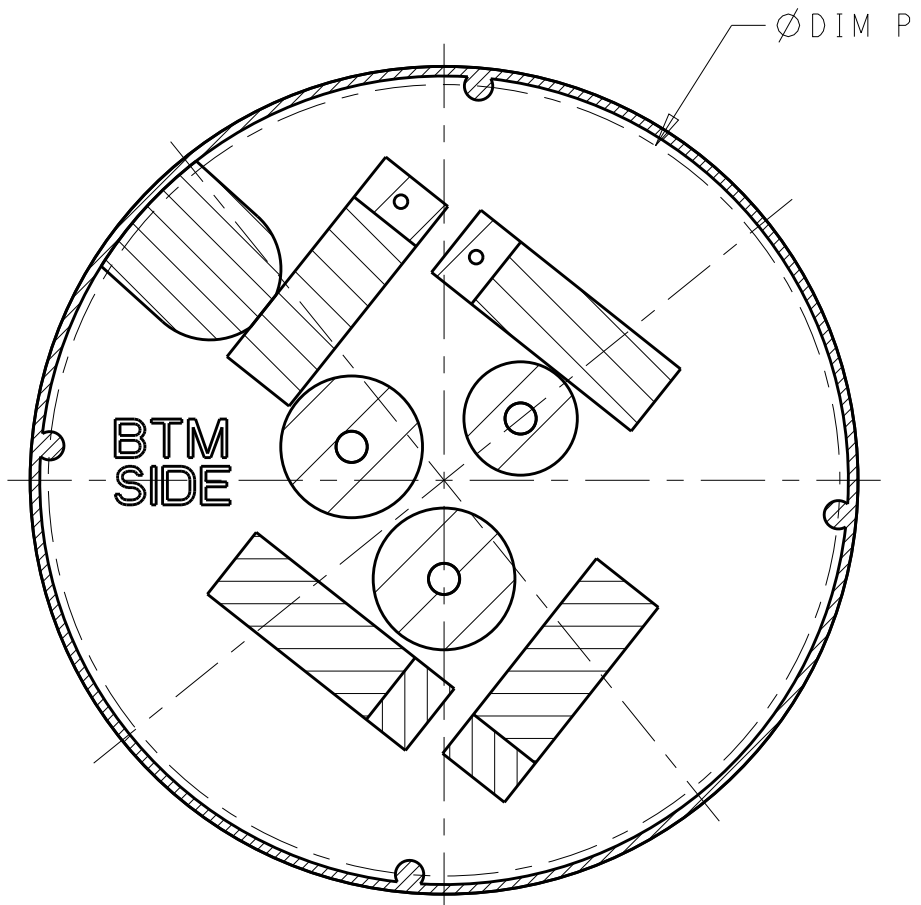
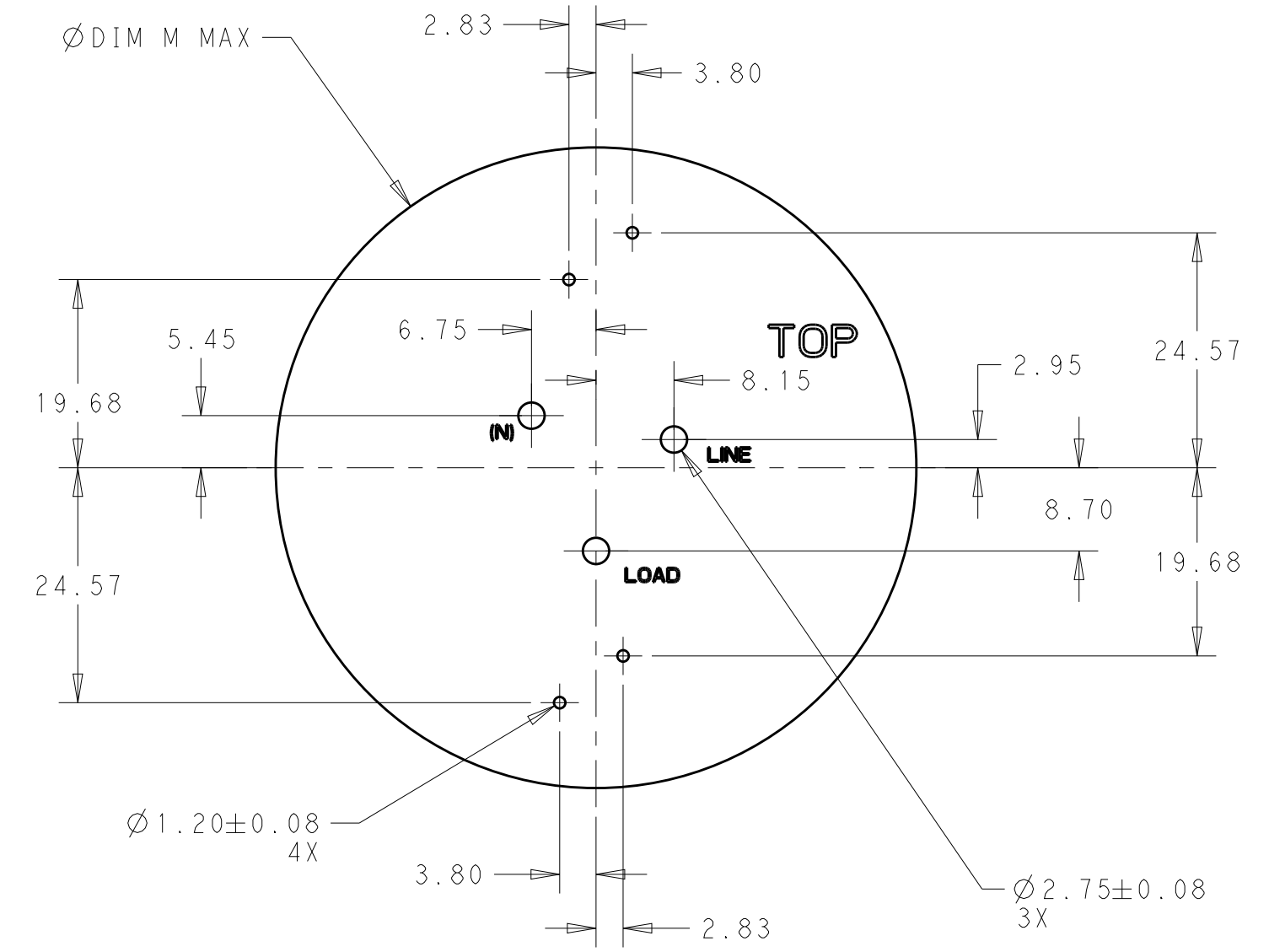

COMPONENT KEEP OUT AREAS  
 1-2336396-1 AND 1-2336396-2  
 SAME AS  
 2336396-1 AND 2336396-2  
 EXCEPT WHERE SHOWN

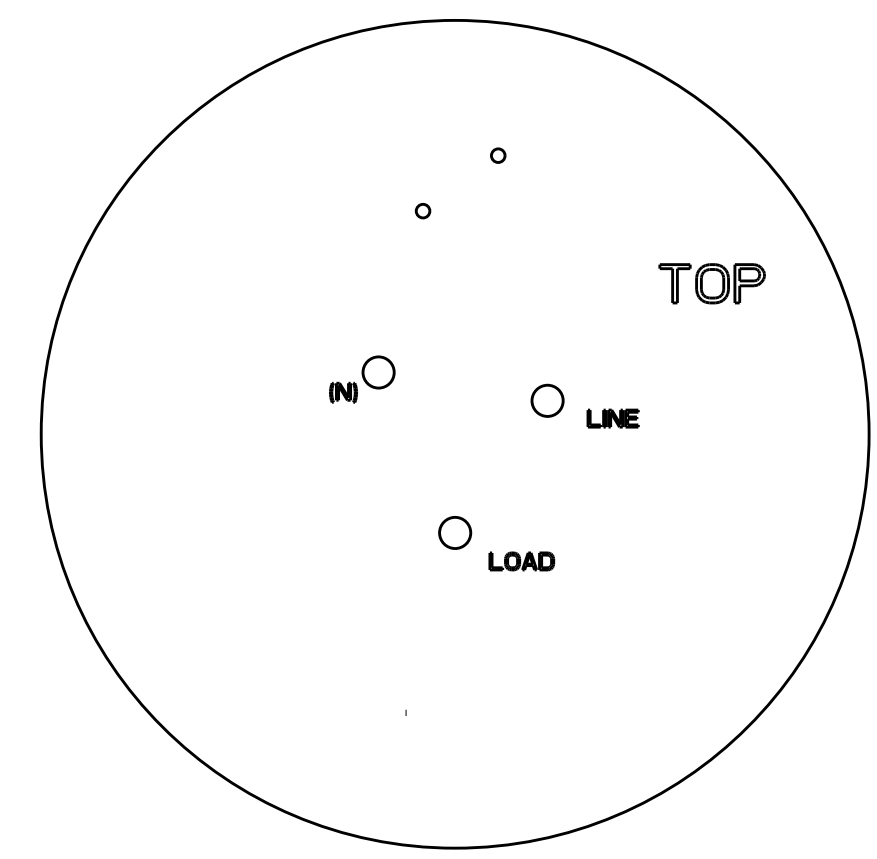

THIS DRAWING IS A CONTROLLED DOCUMENT.		DWN J. SHAFFER 03MAY2018	TE Connectivity	
		CHK M. MOSTOLLER 03MAY2018		
DIMENSIONS:		APVD -	NAME BASE ASSEMBLY, LIGHT CONTROLLER, SLEEVE COMPATIBLE	
mm	TOLERANCES UNLESS OTHERWISE SPECIFIED:	PRODUCT SPEC 108-32125	SIZE A2	
	0 PLC ±	APPLICATION SPEC 114-32159	CAGE CODE -	DRAWING NO. C-2336396
	1 PLC ±0.2	WEIGHT -	RESTRICTED TO -	
	2 PLC ±0.13	CUSTOMER DRAWING	SCALE 2:1	SHEET 3 OF 5
	3 PLC ±		REV A2	
	4 PLC ±			
	ANGLES ±3°			
	FINISH			

THIS DRAWING IS UNPUBLISHED. RELEASED FOR PUBLICATION 20  
 © COPYRIGHT 20 BY - ALL RIGHTS RESERVED.

REVISIONS				
P	LTR	DESCRIPTION	DATE	APVD
-	-	SEE SHEET 1	-	-

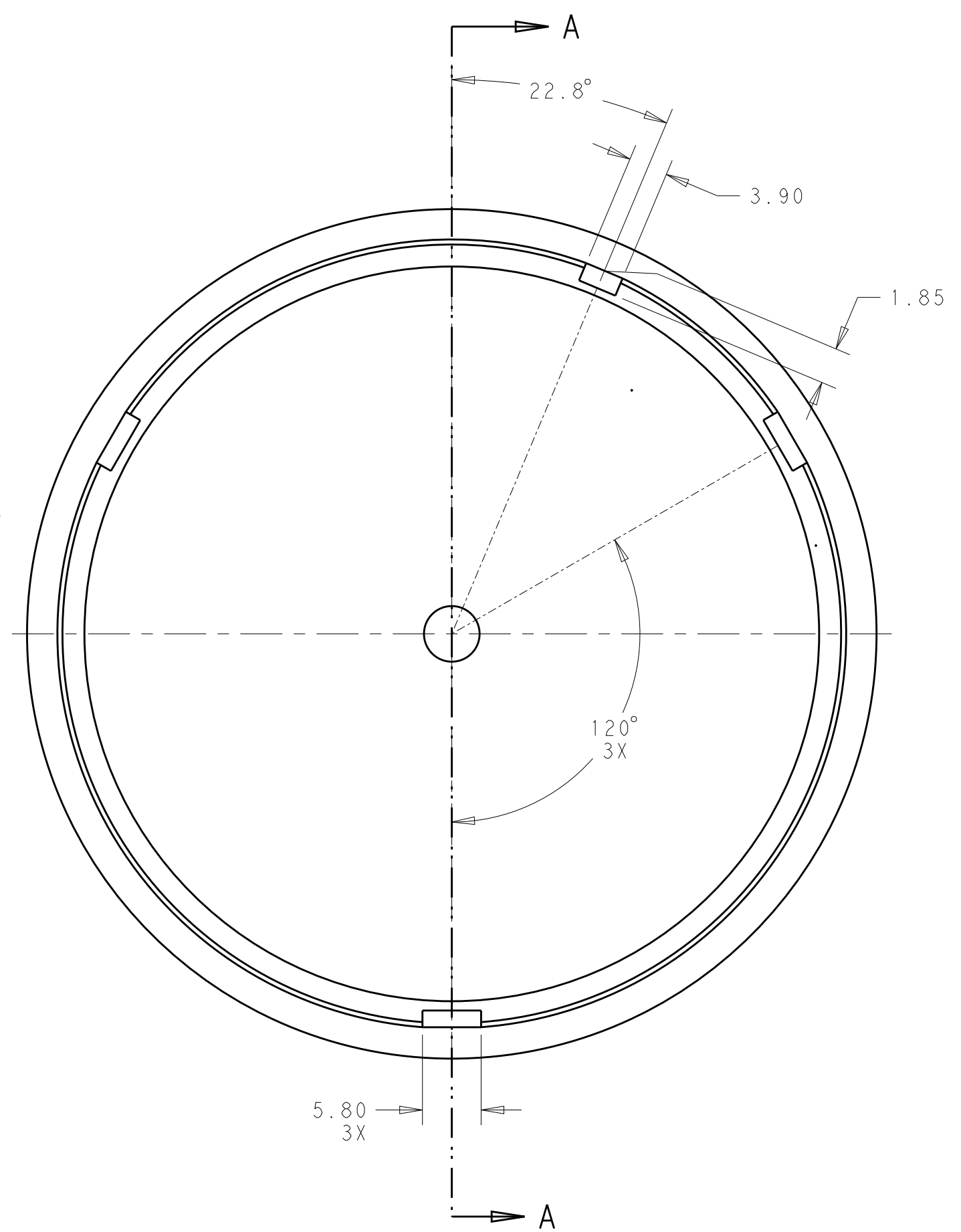
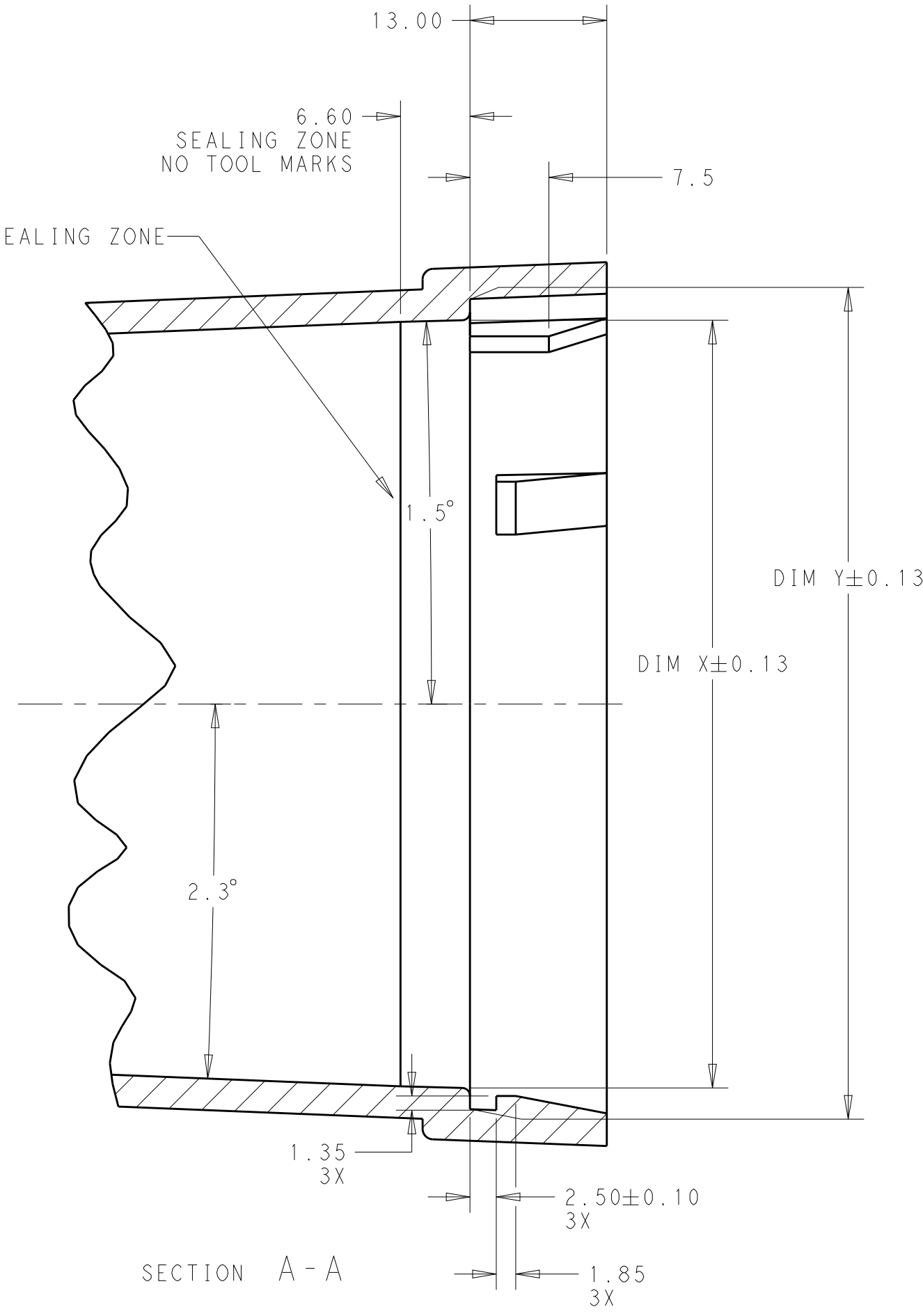
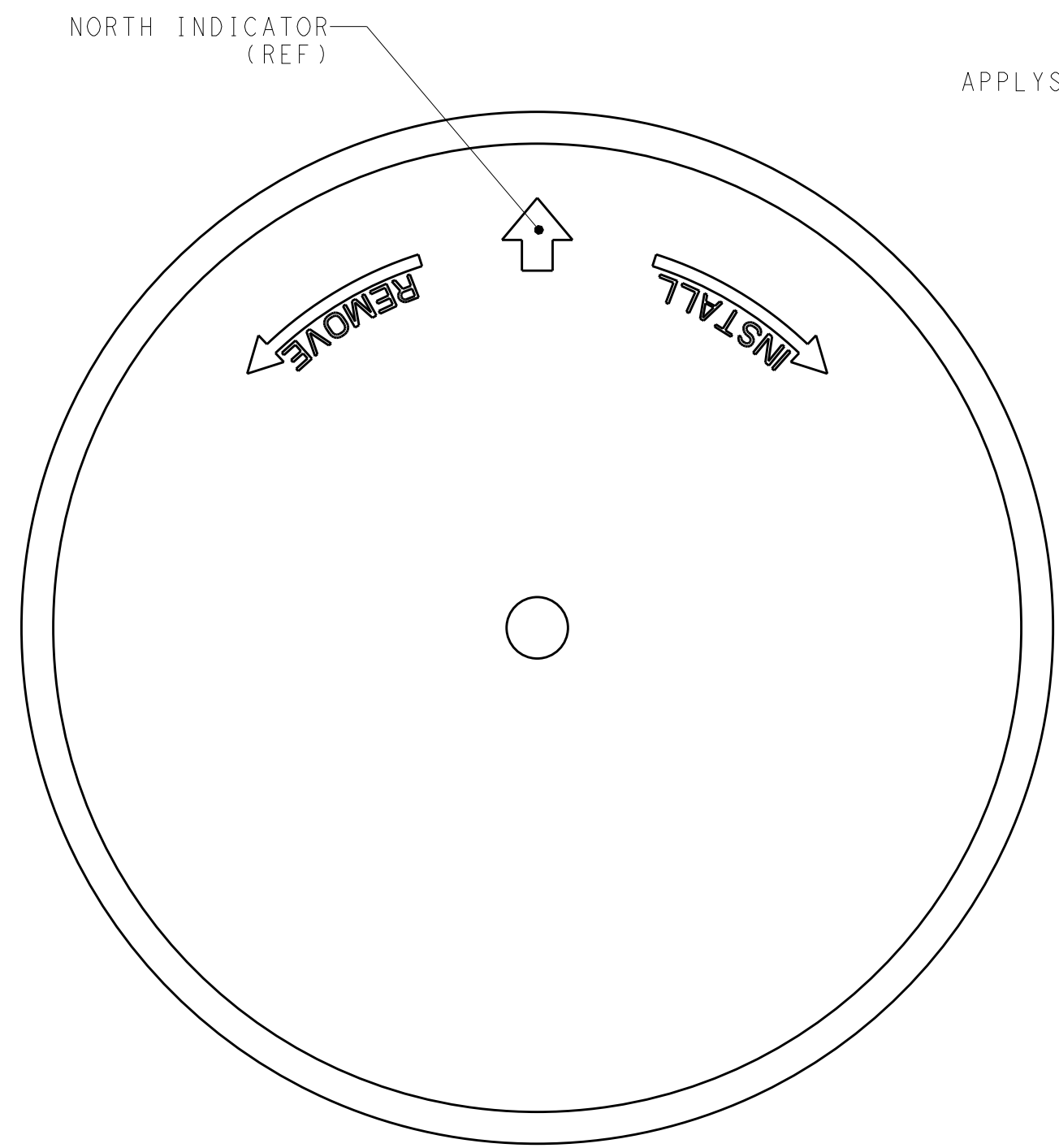

MATING COVER DIMENSIONS  
 FOR  
 76MM DIAMETER BASES  
 (2336396-1, 1-2336396-1)

THIS DRAWING IS A CONTROLLED DOCUMENT.		DWN J. SHAFFER 03MAY2018	 TE Connectivity	
DIMENSIONS: mm		CHK M. MOSTOLLER 03MAY2018		
TOLERANCES UNLESS OTHERWISE SPECIFIED:		APVD -	NAME BASE ASSEMBLY, LIGHT CONTROLLER, SLEEVE COMPATIBLE	
0 PLC ±	1 PLC ±0.2	PRODUCT SPEC 108-32125	SIZE A2	CAGE CODE -
2 PLC ±0.13	3 PLC ±	APPLICATION SPEC 114-32159	DRAWING NO C-2336396	RESTRICTED TO -
4 PLC ±	ANGLES ±3°	WEIGHT -	SCALE 2:1	SHEET 4 OF 5
MATERIAL -	FINISH -	CUSTOMER DRAWING	REV A2	

THIS DRAWING IS UNPUBLISHED. RELEASED FOR PUBLICATION 20  
 © COPYRIGHT 20 BY - ALL RIGHTS RESERVED.

REVISIONS				
P	LTR	DESCRIPTION	DATE	APVD
-	-	SEE SHEET 1	-	-

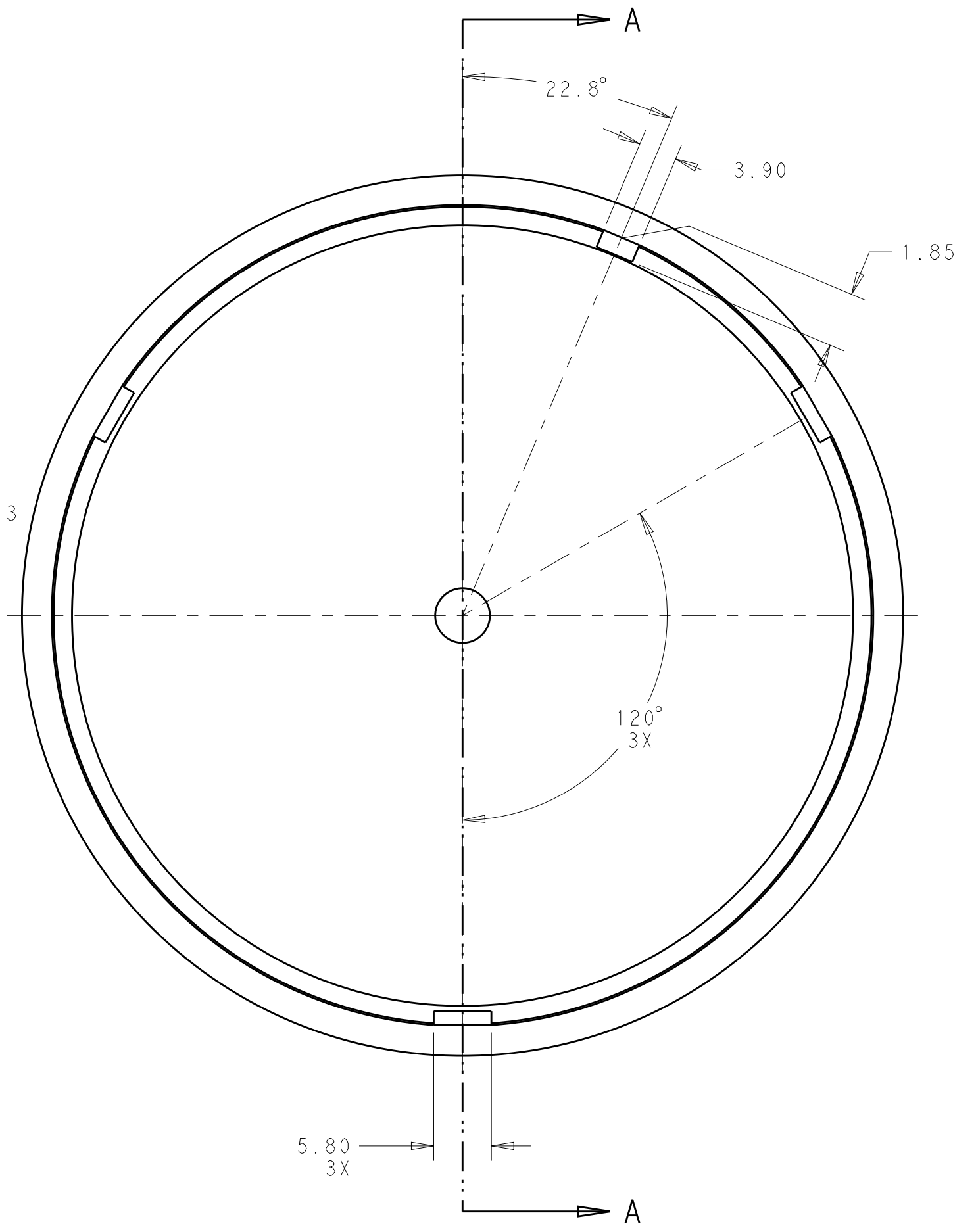
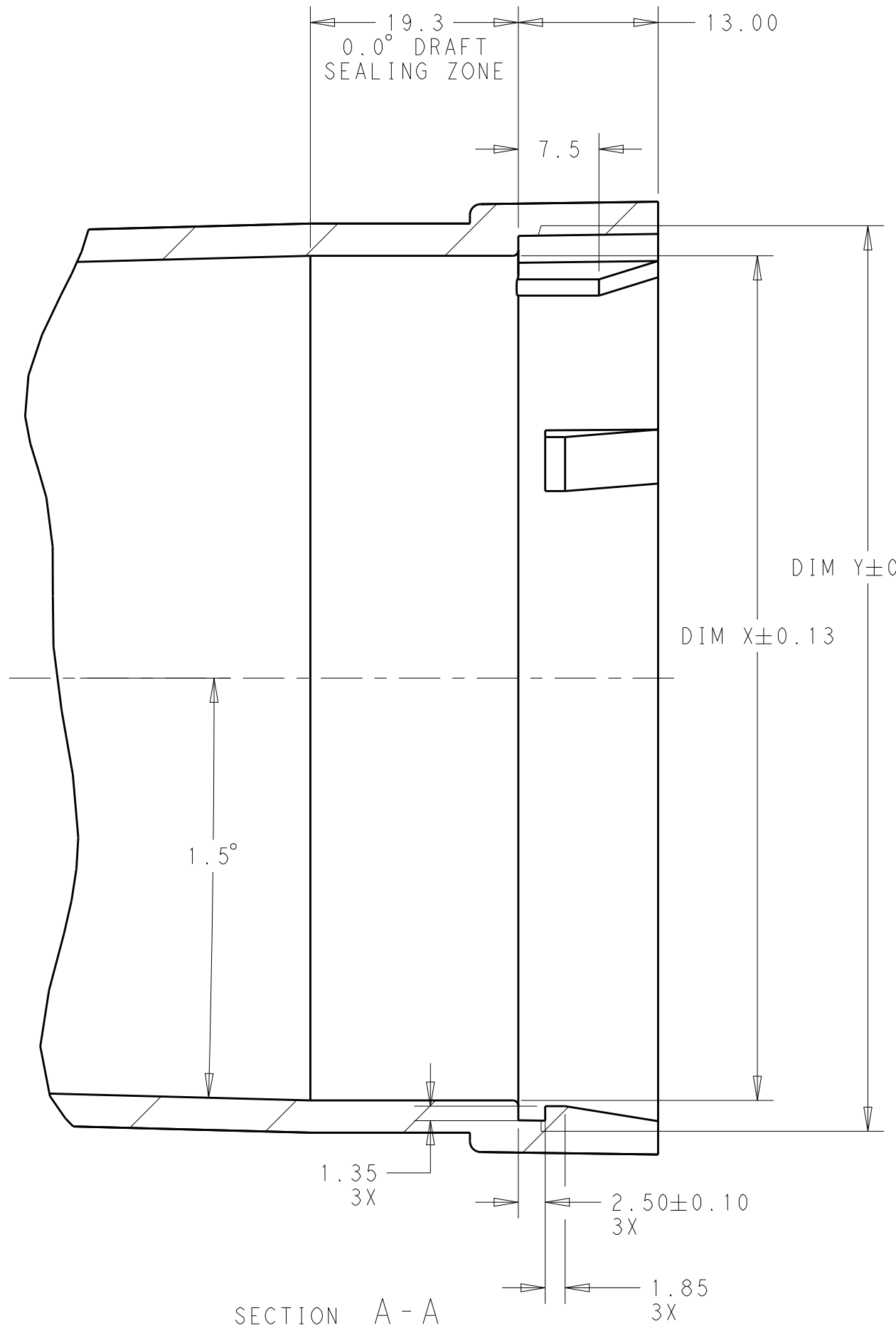
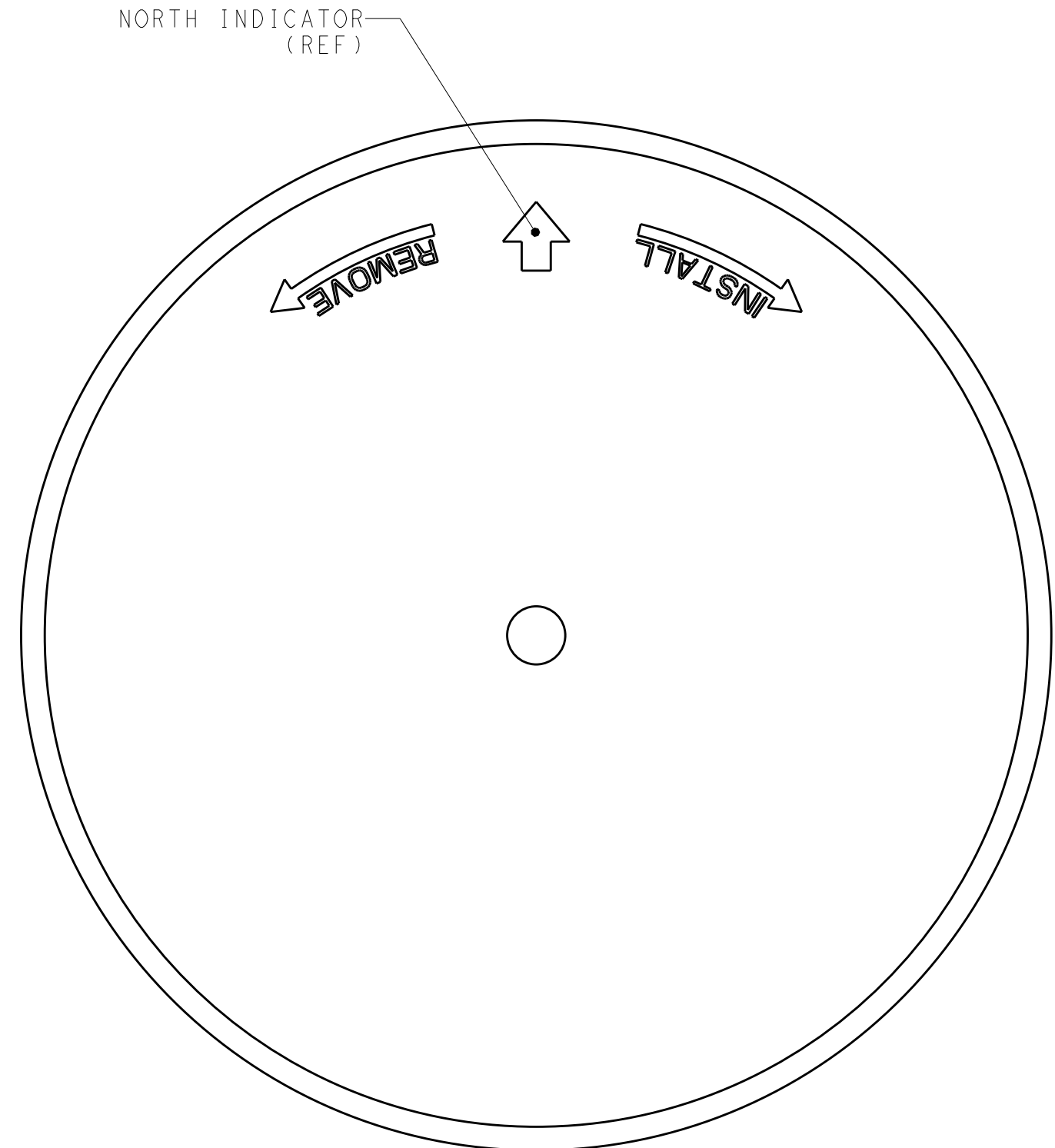

MATING COVER DIMENSIONS  
 FOR  
 81MM DIAMETER BASES  
 (2336396-2, 1-2336396-2)

THIS DRAWING IS A CONTROLLED DOCUMENT.		DWN J. SHAFFER 03MAY2018	 TE Connectivity	
DIMENSIONS:		CHK M. MOSTOLLER 03MAY2018		
mm	TOLERANCES UNLESS OTHERWISE SPECIFIED:	APVD -	NAME BASE ASSEMBLY, LIGHT CONTROLLER, SLEEVE COMPATIBLE	RESTRICTED TO
0 PLC ±	1 PLC ±0.2	PRODUCT SPEC 108-32125	SIZE A2	CAGE CODE -
2 PLC ±0.13	3 PLC ±	APPLICATION SPEC 114-32159	DRAWING NO C-2336396	SCALE 2:1
4 PLC ±	ANGLES ±3°	WEIGHT -	SHEET 5 OF 5	REV A2
MATERIAL -	FINISH -	CUSTOMER DRAWING		