



Model 200i/400i

Recirculating fume extraction is now extremely important with the rising concern for our environment and employee safety. Purex Fume Extractors provide not only a flexible and portable process for plant redesigns and expansions, but also a more stable process by providing a controlled airflow to remove harmful fumes. All this while eliminating the added costs of building modifications, increased air handling systems and lost energy.

## Purex Digital Systems

- ❖ Automatic Flow Control maintains constant extraction rate
- ❖ Adjustable Air Flow extends filter life
- ❖ Blocked Filter Warning
- ❖ Easy to change filters
- ❖ Low energy consumption
- ❖ Quiet operation
- ❖ Welded stainless steel construction
- ❖ Reverse Air Flow prevents condensation and extends filter life
- ❖ Continuous run brushless motors
- ❖ HEPA filtration removes 99.997% of particles down to .3 microns
- ❖ Gas and particle sensors on exhaust
- ❖ Filter Blocked Monitor
- ❖ Gas Safety Sensor
- ❖ Particle Safety Sensor
- ❖ Motor Run Indicator
- ❖ Airflow reading
- ❖ Filtered air temperature
- ❖ Quick-read visual display
- ❖ Remote Machine Interface

# 200i and 400i Vacuum Control

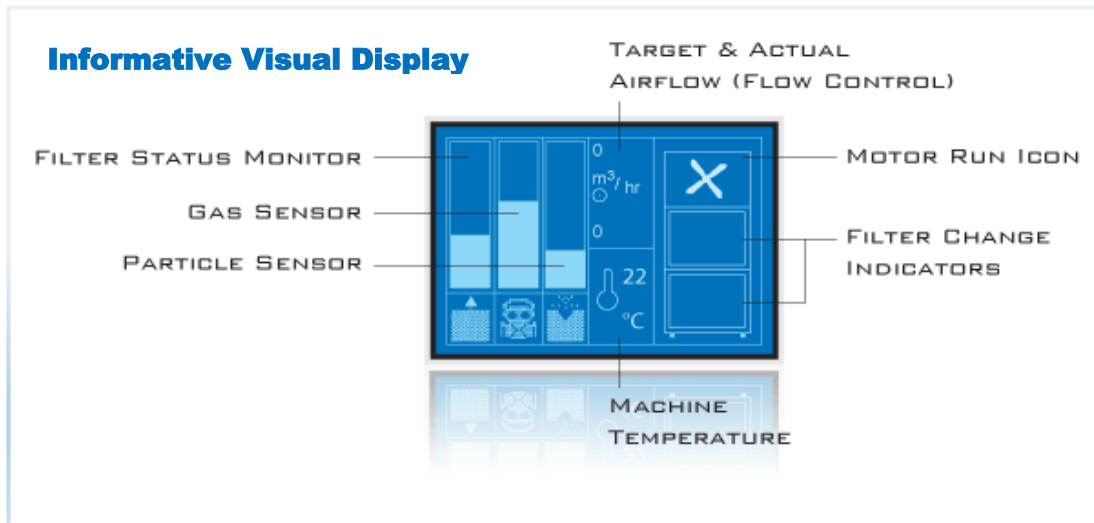

### Main Filter Options



HEPA/Chemical	113505EB
HEPA/Twin Chemical	113579EB
HEPA Chemical Cleanroom*	113512EB
Chemical	113508EB

\*Use F8/F9 Pre-filter

### Labyrinth Pre-Filter Options



F6 (std) 60-80% eff 1-3μ	202268EB
F8/F9 Composite >95% eff .5-1 μ	202271EB

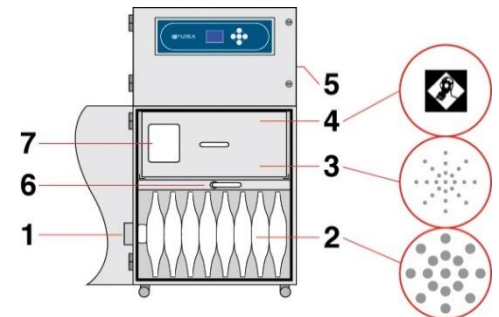

- 1) Air inlet
- 2) Pre-filter
- 3) Main filter (HEPA)
- 4) Main filter (Carbon)
- 5) Clean air return
- 6) Filter lock Handle
- 7) Filter I.D. label

	200i		400i	
<b>Model</b>	081026iDEB	080026iDEB	080411DEB	080410DEB
<b>Voltage (50hz/60Hz)</b>	120v (1ph)	230v (1ph)	120v (1ph)	230v (1ph)
<b>Wattage</b>	0.47 kW	0.46 kW	1.37 kW	1.30 kW
<b>Airflow</b>	88 cfm (150 m <sup>3</sup> /Hr)		275 cfm (467 m <sup>3</sup> /Hr)	
<b>Vacuum</b>	69 inwg (17.29 kPa)		40 inwg (9.92 kPa)	
<b>Air Inlet</b>	3.14in (80mm) Safe Seal			
<b>Sound Rating</b>	52 dBA			
<b>Dimensions (L/W/H)</b>	18.3in x 21in x 42.25in			
<b>Weight</b>	132 lbs			