

DiBO EV CHARGING

Cable Assemblies for Type 1



TE Connectivity redesigned its EV Charging Cable Assemblies for Type 1 with an ergonomical design handle to fit security enclosures. The EV charging cable assemblies offer high mating cycles, magnetically operated solid state switches versus a mechanical switch allowing for an increased life expectancy and TE Madison Cable high flex cable for maximum flex life.

Contact assemblies are sealed with a liquid silicon rubber to prevent against corrosion and moisture inside the connector body. Product meets the SAE J1772 specifications, UL Recognized per UL 2251 and RoHS Compliant. Designed with the end user in mind, materials provide a crush-resistant connector body, meet outdoor classification F1 (UL) and are resistant to common automotive fluids.

Environmental

- IP protection when plugged in - IP44
- IP protection when not plugged in - IP66

Key Features

- Improved housing design
- Housing seal for each contact
- TPA Contact Retention
- Integrated cable clamp exceeds SAE J1772
- Internal cable strain relief
- Latch, Inlet lock capable
- Materials are resistant to UV (FI) exposure and common automotive fluids

KEY BENEFITS

- Individual contact seals prevent moisture and potential corrosion of the crimping zone
- Increased lifetime with magnetically operated solid-state switch
- Latch, Inlet Lock Capable wide enough to meet the SAE spec for inlet locking
- TE Madison Cable high flex cable designed to provide maximum flex life

APPLICATIONS

US - Single-ended termination for integration into EVSE by equipment builder

STANDARDS AND SPECIFICATIONS

- SAE 1772 Compliant
- UL Recognized Per UL 2251
- VDE Certification Pending
- RoHS Compliant

Materials

- Contacts: Brass (500 MPa Stress)
- Housing: UL94-0 rated thermoplastic
- Materials are rated UV exposure performance 5Δe and are resistant to common automotive fluids
- 3 + 2 positions for 1-Phase charging

Electrical Specifications

- 32 amps, 600 volts

Mechanical Specifications

- Housing seal for each contact (Liquid Silicon Rubber Seal)
- TPA Contact Retention
- 10,000 mating cycles
- 3 color options (white, black and gray)
- Customized colors (min volume required)

Product Dimensions

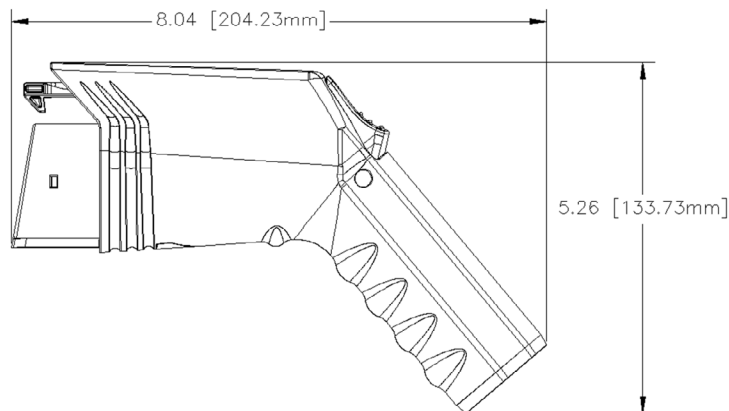

Product Offering

Color Housing Shell	Description	Cable	TE Part No. 10Ft	TE Part No. 15Ft	TE Part No. 20Ft	TE Part No. 25Ft
White	32A, 600 volt	3C 10AWG + 1C 20AWG, black	2267185-1	2267185-2	2267185-3	2267185-4
Gray	32A, 600 volt	3C 10AWG + 1C 20AWG, black	2267220-1	2267220-2	2267220-3	2267220-4
Black	32A, 600 volt	3C 10AWG + 1C 20AWG, black	2267221-1	2267221-2	2267221-3	2267221-4

ENVIRONMENTAL

- IP protection when plugged in - IP44
- IP protection when not plugged in - IP66

CABLE INFORMATION

- 10 AWG, Operating temperature 105 °C