

This document is the property of Amphenol Corporation and is delivered on the express condition that it is not to be disclosed, reproduced or used, in whole or in part, for manufacture or sale by anyone other than Amphenol Corporation without its prior consent, and that no right is granted to disclose or to use any information in this document.

REVISIONS				
SYM	ECN	DESCRIPTION	DATE	APPROVED
A	HK	INITIAL RELEASE	08/15/01	Y.M.LEE

## CUSTOMER INFORMATION DRAWING

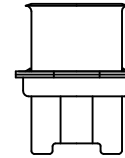
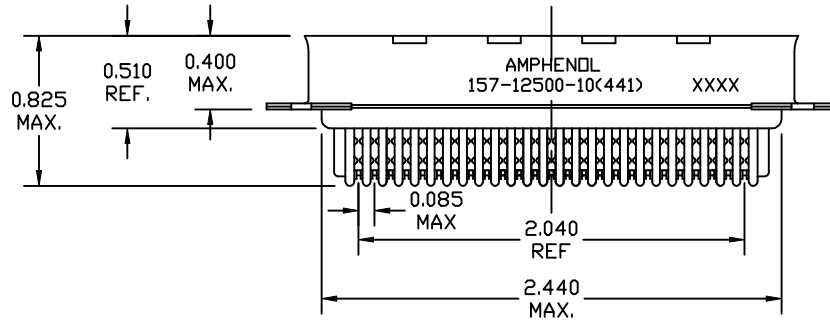
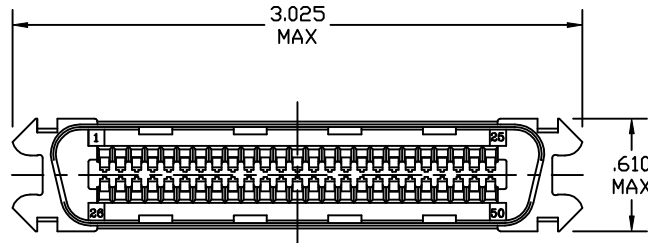

TABLE 1

CONNECTOR SIZES	AVERAGE MATING FORCE (POUNDS)
14	5
24	8
36	12
50	15
64	19

### SPECIFICATIONS:

- 1) INSULATION DISPLACEMENT CONTACTS: TO ACCOMMODATE 24-26 AWG SOLID AND 26-28 STRANDED CONNECTOR WIRES.
- 2) DIELECTRIC: PBT GLASS FIBER RE-INFORCED, UL-94V0
- 3) CONTACT MATERIAL: COPPER ALLOY
- 4) CONTACT: 20 MICRO-INCHES MIN. GOLD MATING AREA: 3-5 MICRO-INCHES GOLD TERMINAL AREA: 50 MICRO-INCHES MIN. NICKEL UNDERPLATING ALL OVER.
- 5) SHELL MATERIAL: TIN-LEAD PLATED STEEL WITH CLEAR CHROMATE COATING
- 6) CURRENT CAPACITY: 5 AMPS/CONTACT
- 7) VOLTAGE RATING: 700 VOLTS D.C. AT SEA LEVEL  
200 VOLTS D.C. AT 70,000 FEET
- 8) INSULATION RESISTANCE: >5000 M OHM

- 9) DIELECTRIC WITHSTANDING VOLTAGE: 1200 VAC (RMS) AT SEA LEVEL
- 10) CONNECTOR MATING FORCE: REFER TO TABLE 1.
- 11) CONTACT RETENTION FORCE: 2 LBS MAX.
- 12) DURABILITY: 250 CYCLES MIN.
- 13) VIBRATION: NO INTERRUPTIONS < 1u SEC.
- 14) OPERATING TEMPERATURE: -55°C TO +105°C (-67°F TO +221°F)

ITEM NO	PART OR IDENTIFICATION NO	NOMENCLATURE OR DESCRIPTION	QTY REQ'D
PARTS LIST			
UNLESS OTHERWISE SPECIFIED TOLERANCES		APPROVAL	DATE
U.S. METRIC		DRAWN Y.M. LEE	08/15/01
.X +/- 0.020		CHECKED Y.M. LEE	08/15/01
.XX +/- 0.010		CHECKED	
.XXX +/- 0.005			
FRACTIONS +/-			
ANGLES +/- 1°			
FOR MATERIALS AND FINISHES SEE NOTES		DRAWING FILE :	TITLE
REMOVE SHARP EDGES		\\DRAWING\157\1571250010441.DWG	50 CONTACT PLUG ASSEMBLY ADAPTED FOR SPRING LATCH WITH "GROUNDING" DIMPLES
DIMENSIONS		ANGLE OF PROJECTION	Amphenol East Asia Limited Manufacturing Operation
U.S. INCHES			SIZE DRAWING NO.
-(METRIC) -(MM)			A3 157-12500-10(441)
		SCALE	REV.
		NONE	A
		SHEET 1 OF 1	