

LOC	DIST	REVISIONS					
		P	LTR	DESCRIPTION	DATE	DWN	APVD
-	-		A	REVISED PER ECR-14-007795	29MAY2014	RS	EC
			B	ECO-15-015144: ADD UL.	25NOV2015	EC	EC
			B2	ECO-16-007046	09MAY2016	RS	HS

SAFETY ORGANIZATIONS

THIS FILTER HAS BEEN FORMALLY RECOGNIZED, CERTIFIED OR APPROVED BY THE LISTED AGENCY. THEREFORE, ALL TEST/REQUIREMENTS SPECIFIED IN THE LATEST REVISION OF THE FOLLOWING AGENCY STANDARDS HAVE BEEN MET:

UL

OPERATING SPECIFICATIONS

LINE CURRENT/VOLTAGE: 1600 A, 690 VAC
 LINE FREQUENCY: 50-60 Hz
 NOMINAL LEAKAGE CURRENT: 10mA
 MAXIMUM LEAKAGE CURRENT: 330mA @ 400V, 50HZ
 OPERATING AMBIENT TEMPERATURE RANGE @ RATED CURRENT, I : -10C TO +40C

IN AN AMBIENT, T, HIGHER THAN 40°C, THE MAXIMUM OPERATING CURRENT, I, IS AS FOLLOWS:

$$I_o = I_R \sqrt{\frac{100 - T_o}{60}}$$

RELIABILITY SPECIFICATIONS

STORAGE TEMPERATURE: -40°C TO +85°C
 HUMIDITY: 21 DAYS @ 40°C AND 95% RH

TEST SPECIFICATIONS

INDUCTANCE, NOMINAL: 28.7 µH
 CAPACITANCE @ 1 kHz, 0.25 VAC MAX., 25°C ±1°C:
 LINE TO GROUND, NOMINAL: 2.62 µF
 LINE TO LINE, NOMINAL: 11.9 µF
 DISCHARGE RESISTOR L/G AND L/L I.R.: 666kΩ / 666kΩ
 IR (NO DISCHARGE RESISTOR) 20°C, 50% RH AND 100VDC, MIN: 6000MΩ

RECOMMENDED RECEIVING INSPECTION HIPOT

LINE TO GROUND FOR 1 MINUTE: 2640 VDC
 LINE TO LINE FOR 1 MINUTE: 2520 VDC

FILTER APPROVAL:

THE BEST WAY TO SELECT AND QUALIFY A FILTER IS FOR YOUR ENGINEERING TO TEST THE UNIT IN YOUR EQUIPMENT.

20

RELEASED FOR PUBLICATION

ALL RIGHTS RESERVED.

THIS DRAWING IS UNPUBLISHED.

BY -

© COPYRIGHT 20

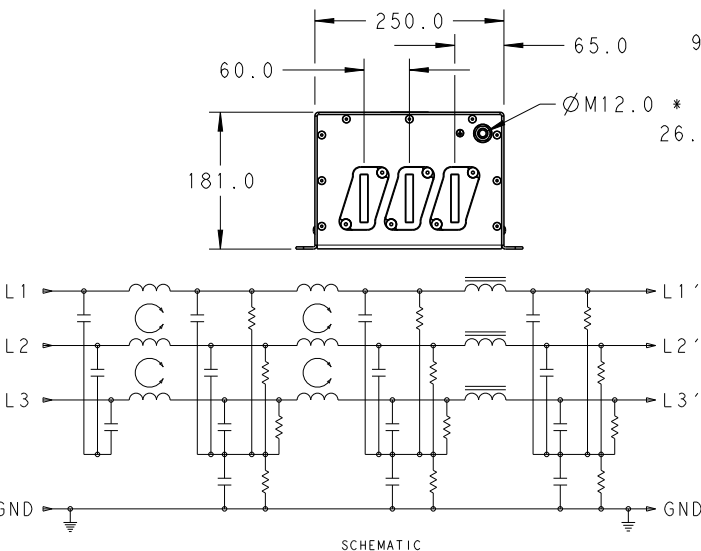
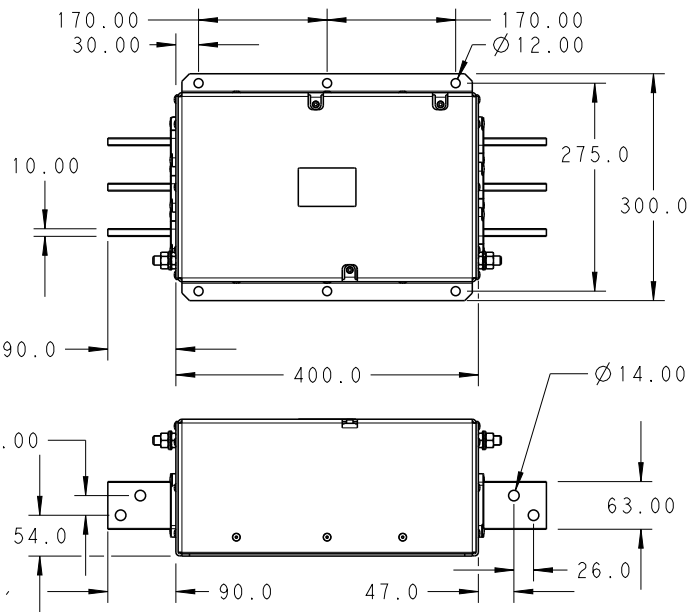
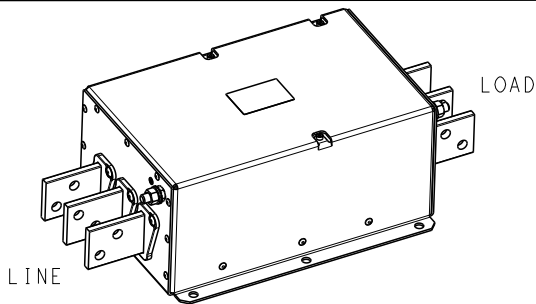

* DO NOT LOOSEN INNER GROUND NUTS. TORQUE OUTER GROUND NUTS TO: 25-30 NM [220-260 IN-LB]

TYPICAL INSERTION LOSS
 COMMON MODE 50/50 Ω; DIFFERENTIAL MODE 100/100 Ω

MHz	0.01	0.05	0.15	0.5	1.0	3.0	5.0	10	30
CM	11	12	56	87	72	60	48	33	22
DM	32	45	70	62	52	42	37	32	24

DIMENSIONS: mm	DWN RS	16DEC2013	MATERIAL	FINISH
TOLERANCES UNLESS OTHERWISE SPECIFIED:	CHK EC	16DEC2013	TE Connectivity	
0 PLC ±2.0 1 PLC ±1.0 2 PLC ±0.50 3 PLC ±0.200 4 PLC ±0.1000 ANGLES ±-	APVD EC	16DEC2013		
	PRODUCT SPEC		NAME 1600APH12P 3-PHASE DELTA FILTER	
	APPLICATION SPEC		SIZE	CAGE CODE
	WEIGHT		A 4	00779
	CUSTOMER DRAWING		DRAWING NO	RESTRICTED TO
			C-9-1609148-1	-
			SCALE	SHEET
			2:15	1 OF 1
				REV
				B2