

PRODUCT DATA DRAWING

REVISION HISTORY			
REV	DESCRIPTION	DATE	APPROVED
-	REL DCN 47096	01/09/18	STW

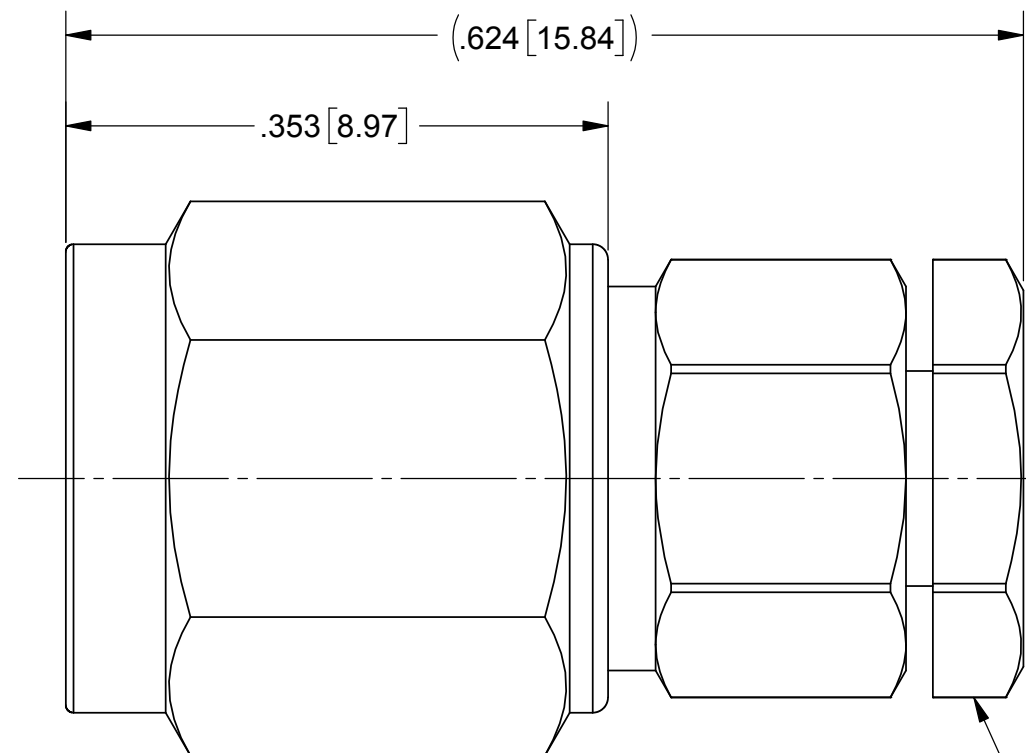

2X .250[6.35] HEX

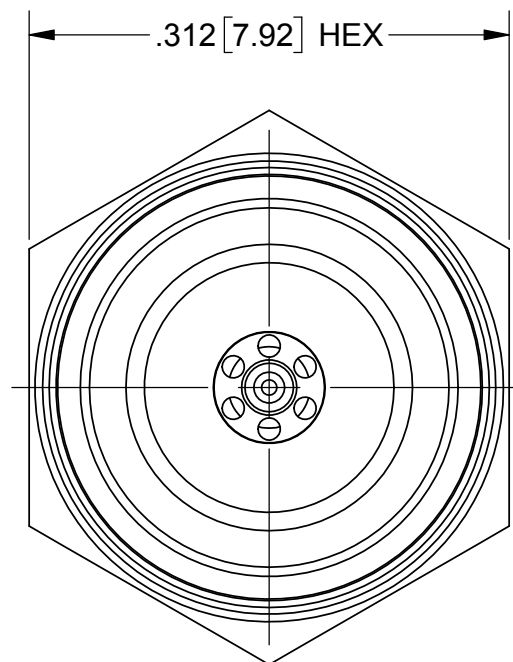
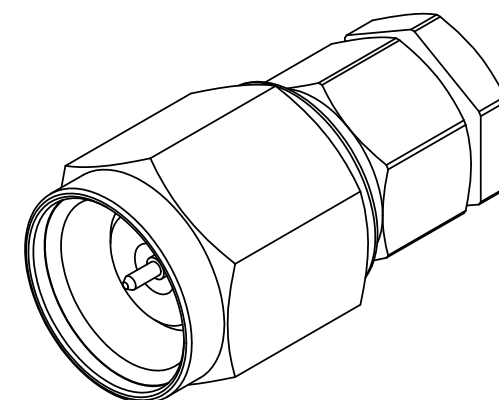

MATERIAL:

BODY, CLAMP NUT,
COUPLING NUT &
FERRULE:

STAINLESS STEEL PER AMS-5640,ALLOY UNS S30300, TYPE 1
OR ASTM A582, TYPE 303, CONDITION A.

CONTACT:

BERYLLIUM COPPER PER ASTM B196, ALLOY No. UNS C17300, TD04.

LOCK RING:

BERYLLIUM COPPER PER ASTM B194, B196 OR B197 ALLOY No.
UNS C17200 OR C17300, TD04.

INSULATOR:

PEI (ULTEM 1000) PER ASTM D2505.

GASKET:

SILICONE RUBBER PER A-A-59588, CLASS 2B, GRADE 60/70.

FINISH:

CONTACTS &
FERRULE:

GOLD PER ASTM B 488, TYPE II, CODE C, CLASS 1.27
OVER NICKEL PER AMS-QQ-N-290, CLASS 1, .00005" MIN.

BODY, CLAMP NUT &
COUPLING NUT:

PASSIVATED PER AMS 2700

PERFORMANCE:

IMPEDANCE: 50 OHMS
FREQ. RANGE: DC TO 65.0 GHz
VSWR: 1.33:1 DC TO 65.0 GHz
INSERTION LOSS: .03 X SQRT F(F IN GHz)
DWV: 500 VRMS
OPERATING TEMP.: -55°C TO +125 °C

ENGAGEMENT/
DISENGAGEMENT: 2 IN-LBS

MATERIAL: SEE NOTES	DIMENSIONS ARE IN INCHES TOLERANCES: FRACTIONAL: ±1/64 ANGULAR: X° ±1'0" X'X' ±15'	UNLESS OTHERWISE SPECIFIED 1) ALL DIMENSIONS ARE IN INCHES (MILLIMETERS) 2) ALL DIMENSIONS ARE AFTER PLATING. 3) BREAK CORNERS & EDGES .005 R. MAX. 4) CHAM. 1ST & LAST THREADS. 5) SURFACE ROUGHNESS 63-MIL-STD-10. 6) DIA. 'S ON COMMON CENTERS TO BE CONCENTRIC WITHIN .005 T.I.R. 7) REMOVE ALL BURRS	 2400 Centrepark West Drive, Suite 100 West Palm Beach, FL 33409 TITLE: 1.85MM PLUG FOR Ø.047 CABLE
FINISH: SEE NOTES	DECIMAL: X ±.030 .XX ±.010 .XXX ±.005	INTERPRET DIMENSIONS AND TOLERANCES PER ASME Y14.5M - 1994	
SURFACE AREA: N/A	THIRD ANGLE PROJECTION	DRAWN: JMC 01/08/18	SIZE: B CAGE CODE: 95077 DWG. NO. SF3311-60008
PROPRIETARY THE INFORMATION CONTAINED IN THIS DRAWING IS THE SOLE PROPERTY OF SV MICROWAVE, INC. ANY REPRODUCTION IN PART OR AS A WHOLE WITHOUT THE WRITTEN PERMISSION OF SV MICROWAVE, INC IS PROHIBITED.		CHECKED: STW 01/09/18	SCALE: 8:1 SHEET 1 OF 1
		APPROVED: STW 01/09/18	