

Power Management

Programmable Power
Universal PMICs

Power Conversion
Power Modules
Switching Regulators
Advanced DrMOS
Switching Controllers
DDR Termination
Linear Regulators
LDOs

System Controls
Power Switches
Voltage References
Supervisors

LED Lighting
AC Step Drivers
Switching Regulators

Table of Contents

Power Management Portfolio.....	3
Programmable Power.....	4
Universal PMICs.....	4
PowerArchitect™ – Configuration Software.....	7
Evaluation Boards.....	7
Power Conversion.....	9
Power Modules.....	9
Switching Regulators.....	10
AEC-Q100 Qualified Regulators.....	10
Step-Down Regulators >20V.....	11
Step-Down Regulators.....	12
Step-Up Regulators.....	14
Advanced DrMOS.....	14
Switching Controllers.....	15
DDR Termination.....	16
Linear Regulators.....	16
LDOs.....	17
System Controls.....	19
Power Switches.....	19
Voltage References.....	19
Supervisors.....	20
LED Lighting.....	21
AC Step Drivers.....	21
Switching Regulators.....	22

Power Management Portfolio

Programmable Power			
Triple PMICs		Quad PMICs	
XR7713		XRP7704	XRP7724
XR77103		XRP7714	XR77128
		XRP7740	MxL7704-A
			MxL7704-X

Power Conversion											
Power Modules	Switching Regulators				Power Stage	Switching Controllers	Linear				
	AEC-Q100 Qualified	Step-Down >20V	Step-Down	Step-Up	Advanced DrMOS	Step-Down	LDOs		DDR Termination	Linear Regulators	
XR79110	XR76203-Q	SP7650	SP6652	SP6641	XR78021	SP6123	LP2951	SPX1117	SPX2941	XRP2997	SP78L05
XR79115	XR76205-Q	SP7651	SP6654	SP6661		SP6128	SP6201	SPX1582	SPX2945		
XR79120	XR76208-Q	SP7652	SP6669	SP6648		SP6132	SP6203	SPX1587	SPX2954		
XR79103		SP7662	XRP6657	SP34063		SP6133	SP6205	SPX2815	SPX3819		
XR79106		XRP7662	XRP6658			SP6134	SP6213	SPX29150	SPX3940		
XR79203		XR76108	XRP6668			XRP6124	SP6260	SPX29152	SPX5205		
XR79206		XR76112	SP34063			XRP6141		SPX29300	XRP29302		
MxL7204		XR76115	XRP6670			XR75100		SPX29301	XRP6272		
		XR76117	XRP7659					SPX29302			
		XR76121	XRP7675								
		XR76203	XRP7664								
		XR76205	XRP7665								
		XR76208									
		XR76201									

System Controls						
Power Switches		Voltage References		Supervisors		
Single	Dual					
SP2525A	SP2526A	SPX1431	SPX2431	SP690	SP691	SP705
SP619	XRP2526	SPX385	SPX431L	SP706	SP707	SP708
		SPX432	SPX431A	SP813	SP809	

LED Lighting				
AC Step Drivers		Switching Regulators		
		Step-Down	Step-Up/Down	Step-Up
XR46203	XR46084	XRP7613	SP6686	SP6699
XR46110	XR46083		SP7685	
XR46073	XR46010			
XR46050	XR46014			
XR46701	XR46000			

Programmable Power

MaxLinear's universal PMICs with programmable power technology offer advanced dynamic control, telemetry and remote reconfigurability. PowerArchitect design and configuration software speeds development and significantly reduces overall time to market compared to legacy analog power solutions. An I²C interface and multiple GPIO pins ensure easy system integration. Configurable warning and fault levels, fault behavior and power up and down sequencing ensure that any load can be properly powered and protected.

Applications

- **FPGA, DSP and ASIC power systems**
- **Base stations**
- **x86 and ARM servers**
- **Networking**
- **Telecommunications**
- **Industrial and embedded systems**

Universal PMICs

Part Number	Ch.	Gate Drive Resistance Up/Down (Ω)	Operating Voltage (V)		Min Output Voltage (V)	Quiescent Current (mA)	Programmable Frequency Range (MHz)	Package	Features
			Min	Max					
XR77103*	3	Integrated MOSFETs	4.5	14	0.8	1.5	0.3 to 2.2	TQFN-32	<ul style="list-style-type: none"> ▪ Synchronous ▪ UVLO, OTP, soft-start ▪ Light load efficiency - PFM and PWM mode ▪ Overcurrent and output overvoltage protection ▪ I²C reconfigurable
MxL7704-A	4	1.5A 1.5A 2.5A 4A	4.5	5.5	3.0 1.3 0.8 0.6	8	1 to 2.1	QFN32	<ul style="list-style-type: none"> ▪ Two configurable power good outputs ▪ LDO and 2-input 8-bit ADC ▪ Temperature monitoring ▪ Supported by Excel configuration tool ▪ Sequencing I/O first, core last
MxL7704-X	4	1.5A 1.5A 2.5A 4A	4.5	5.5	3.0 1.3 0.8 0.6	8	1 to 2.1	QFN32	<ul style="list-style-type: none"> ▪ Two configurable power good outputs ▪ LDO and 2-input 8-bit ADC ▪ Temperature monitoring ▪ Supported by Excel configuration tool ▪ Sequencing for Xilinx® Zynq® UltraScale+™ ZU2/3
XR77129	4	4/2	6	40	0.6	4	0.1 to 1.2	TQFN-44	<ul style="list-style-type: none"> ▪ 40V digital PWM/PFM controller ▪ I²C reconfigurable ▪ Built-in 3.3V/5V LDO ▪ Integrated MOSFET drivers
XR77128	4	4/2 DrMOS output	4.75	25					<ul style="list-style-type: none"> ▪ Updated fault management and GPIO functionality, with the ability to drive MOSFETs and DrMOS
XRP7724	4	4/2	4.75	25	0.6	4	0.1 to 1.2	TQFN-44	<ul style="list-style-type: none"> ▪ Digital PWM controller with DPFM mode ▪ I²C reconfigurable ▪ Built-in 3.3V/5V LDO ▪ Integrated MOSFET drivers ▪ Full protection
XRP7725			4.75	25					<ul style="list-style-type: none"> ▪ Intel® Node Manager compatible ▪ Programmable power system ▪ XRP7724 pin and function compatible
XRP7713	3	6/3	4.75	25	0.9	9	0.3 to 1.5	TQFN-32	<ul style="list-style-type: none"> ▪ Digital PWM controller ▪ Faults, warnings, sequencing, GPIOs and PID compensation are all I²C reconfigurable ▪ 3.3V or 5V selectable LDO ▪ Integrated MOSFET drivers
XRP7714	4							TQFN-40	
XRP7704	4	- / -	6.5	20	0.9	9	0.3 to 1.5	TQFN-40	
XRP7740	4	3/1.8							

* Preliminary

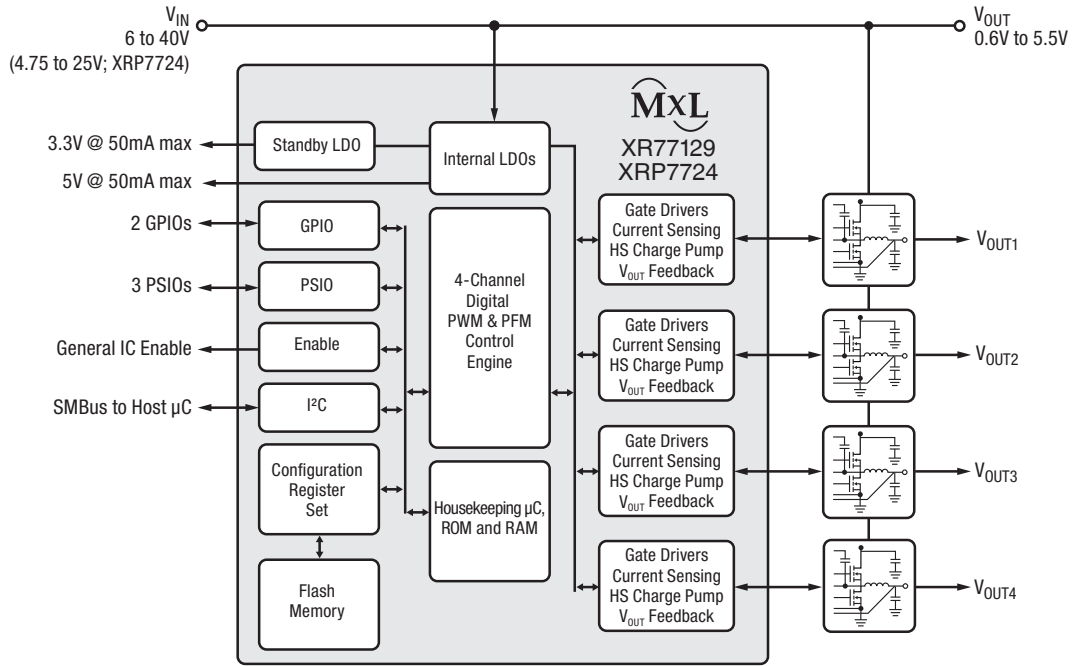

Functional Block Diagram

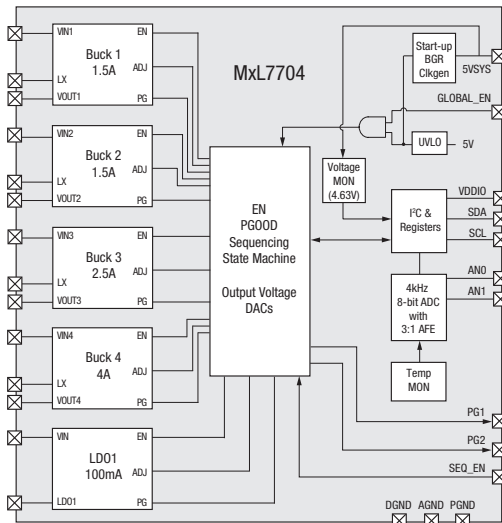

MxL7704 Functional Block Diagram



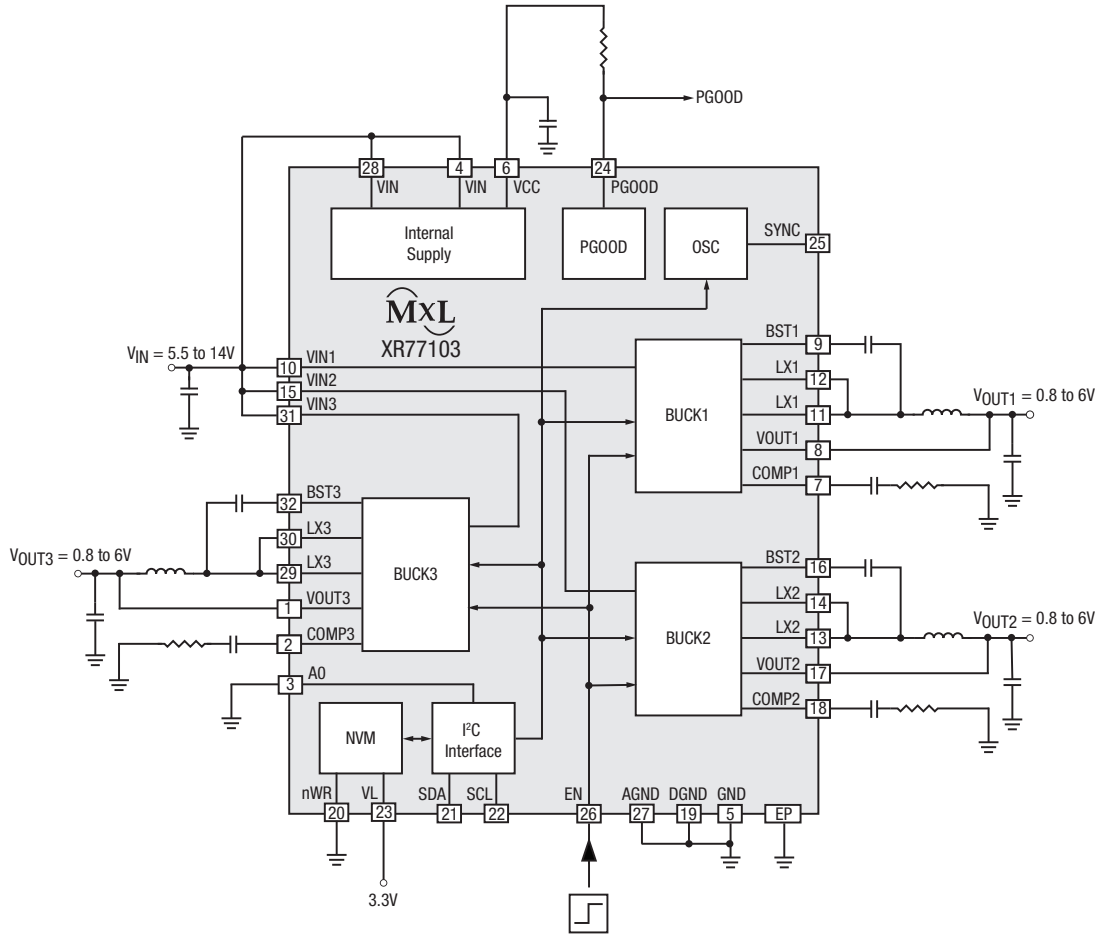

Universal PMIC 3-Output Programmable Buck Regulator Typical Application

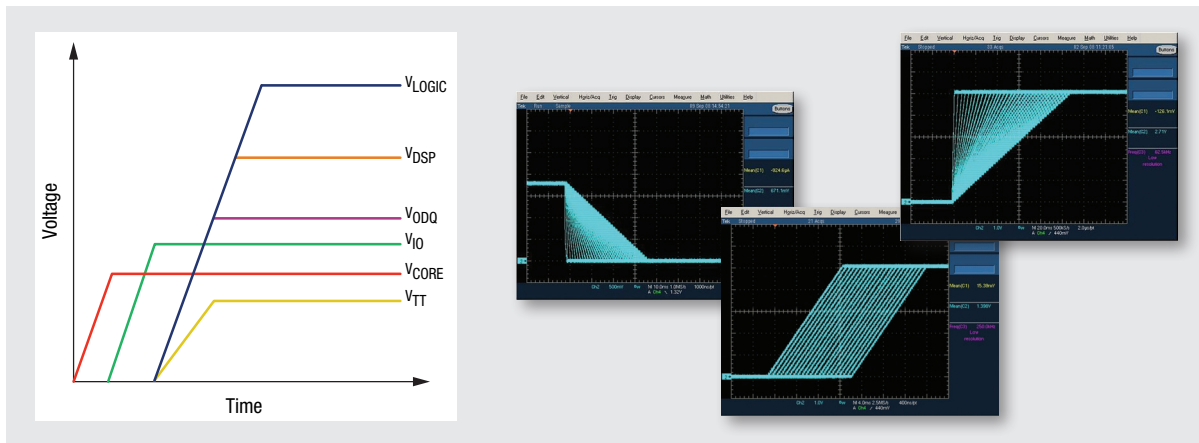

Control Power Up/Down Sequencing with Different Delays and Slopes

PowerArchitect – Configuration Software

MaxLinear's PowerArchitect interactive design tool enables you to create a complete 4- to 6-channel optimized power supply design with complex sequencing and advanced power management features, all with a few clicks of the mouse. A free download of PowerArchitect is available at powerxr.exar.com

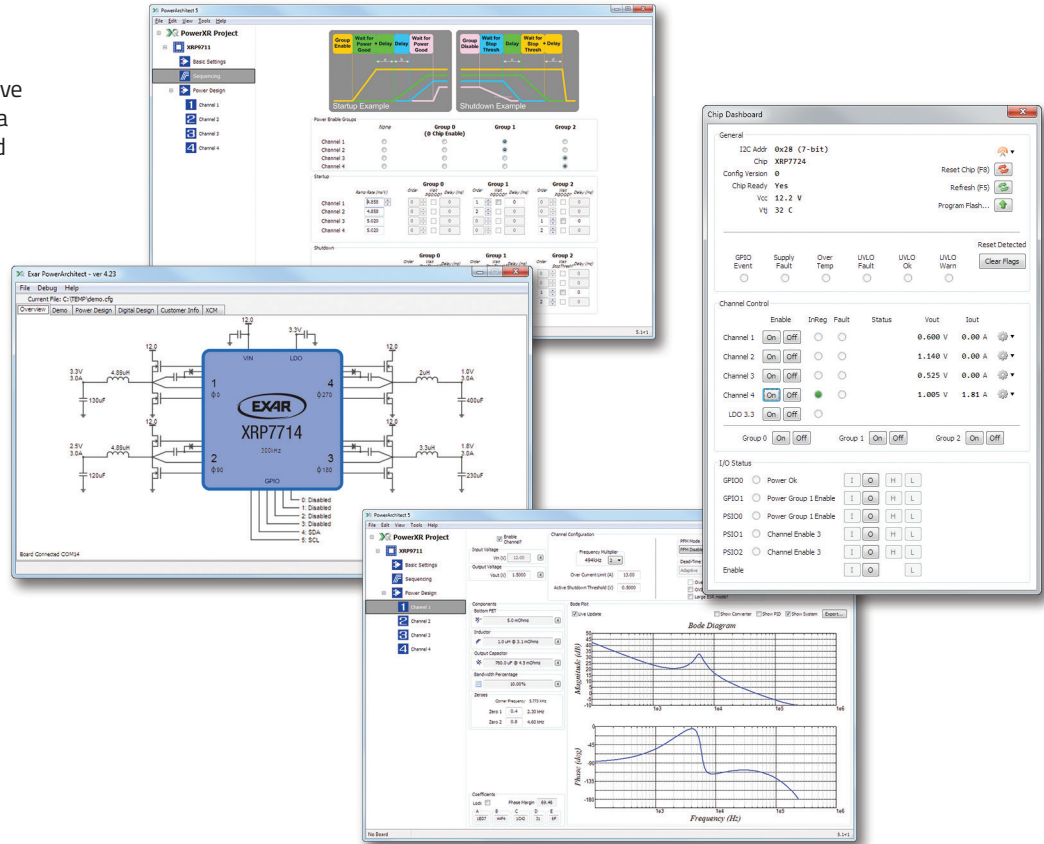

Evaluation Boards

Evaluation boards for all programmable power management devices are available, along with their user manuals.

Complete Programmable Power Kits Available



Zynq-7000 Power System Featuring XRP7714

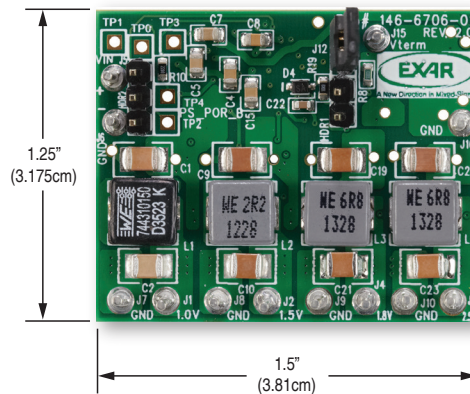

Ready-made configurations for:

- Zynq-7XXX
- i.MX5 and i.MX6
- Smartfusion2
- Cyclone IV
- Cyclone V SOC
- Intel Wellsburg

Power Management Solutions for Xilinx® Zynq® UltraScale+™ MPSoC

MaxLinear offers two power management solutions for use with Xilinx Zynq UltraScale+ MPSoC. These solutions reduce rails to as few as possible yet still meet the UltraScale+ spec. These flexible solutions use internal digital control to easily manage sequencing requirements and allow max current to be adjusted quickly and easily. Visit www.exar.com/xilinx for additional information.

Supported Xilinx UltraScale+ Zynq Devices:

ZU2CG, ZU2EG (A), ZU3CG, ZU3EG, ZU4CG, ZU4EG, ZU4EV, ZU5CG, ZU5EG, ZU5EV, ZU6CG, ZU6EG, ZU7CG, ZU7EG, ZU7EV, ZU9CG, ZU9EG, ZU11EG, ZU15EG, ZU17EG, ZU19EG.

Features

- **Manages sequence and dependency**
- **Provides correctly timed Ps_Por_B**
- **Allows PSU Telemetry**
- **Scalable to meet full Zynq UltraScale+ Family**
- **Optimized to power FPGAs in any system**

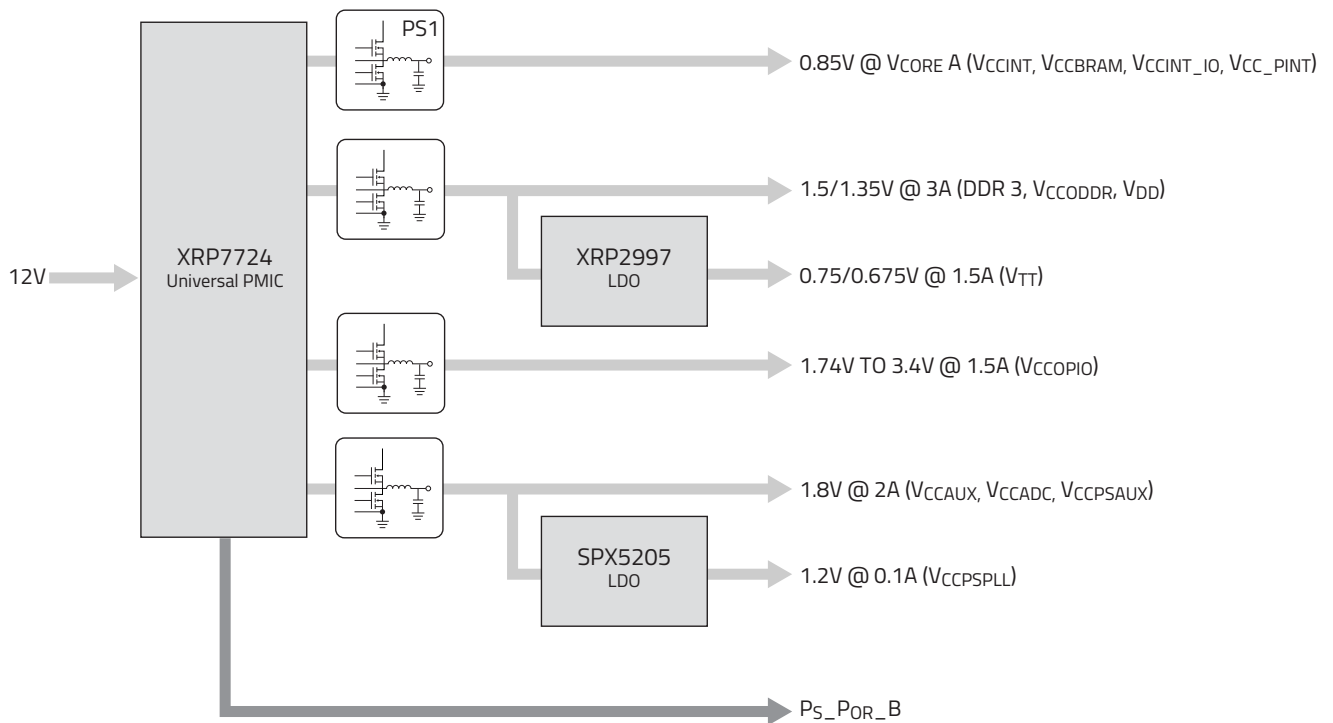

Scalable Zynq UltraScale+ Always on Solution (No MGTs)

Device	Icore (max)	Imgtavtt	Imgtavcc	PS1			
				Qh	Ql	L	C
Zu2, Zu3	8A	3A	3A	FDP8014S (dual)		0.56µH 18A	600µF 3mΩ esr
Zu4, Zu5	16A	3A	3A	FDM3620S (dual)		0.22µH 33A	1200µF 1.6mΩ esr
Zu6, Zu7, Zu9	25A	3A	3A	CSD17304Q3	BSC009NE2LS	0.18µH 50A	1850µF 1.2mΩ esr
Zu11, Zu15, Zu17, Zu19	35A	10A	10A	CSD17304Q4	BSC009NE2LS	0.15µH 80A	2600µF 0.9mΩ esr

Power Modules

MaxLinear's power modules address high-current solutions for various end applications. These synchronous step-down power modules are complete system-in-package power management solutions with fully integrated power converters including MOSFETs, inductors and internal input and output capacitors. Our XR79xxx modules utilize a patented emulated current mode Constant On-Time (COT) control that provides exceptional full range 0.1% line regulation and 1% output accuracy over the full temperature range. This COT control loop enables operation with ceramic output capacitors, eliminating loop compensation components.

Our QFN modules provide superior thermal performance and manufacturability, all in the smallest footprint. The QFN package makes visual inspection of solder joints possible and eases electrical debugging. At 85°C with no airflow, no thermal de-ratings are required for output voltages of 1.8V and below.

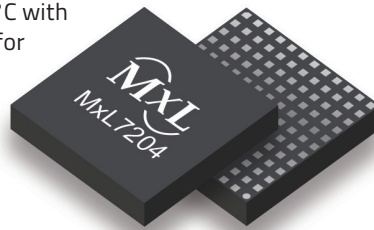

Applications

- FPGA, DSP and ASIC power systems
- Base stations
- Repeaters
- Networking
- Telecommunications
- Industrial and embedded systems

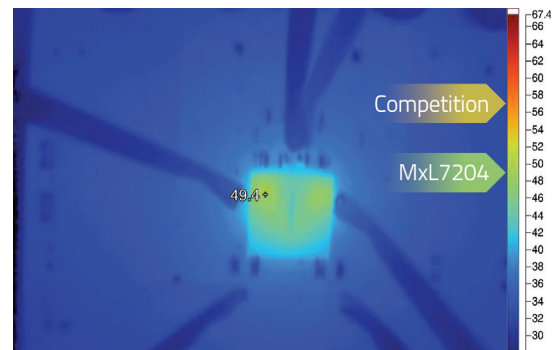
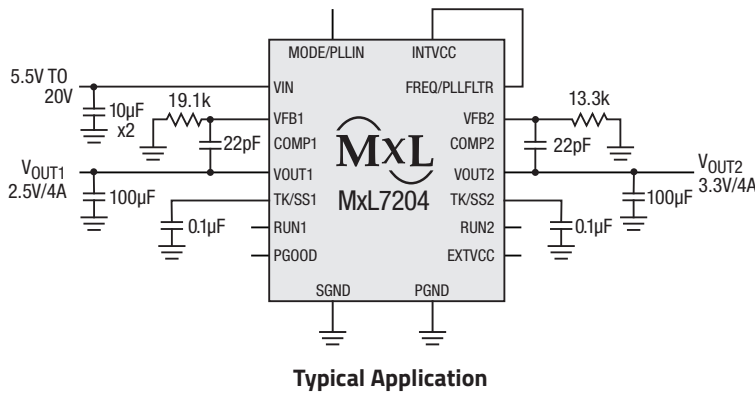
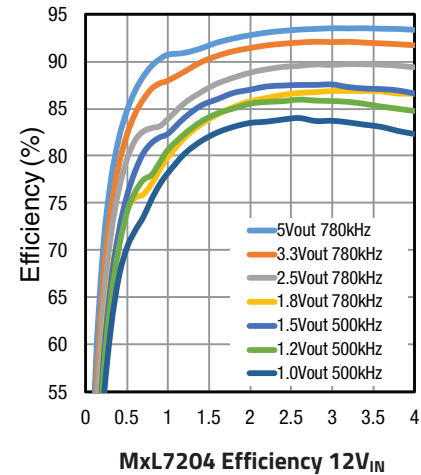

Part Number	Ch.	Output Current (A)	V _{IN} Range (V)	V _{OUT} Range (V)	Frequency (kHz)	Efficiency (%)	X-Y Dimension (mm)	Z Dimension (mm)	Package	Features
XR79203	1	3	3 to 40	0.6 to 13.2	400 to 800	95	8 x 8	4	QFN	<ul style="list-style-type: none"> ▪ Patented COT control ▪ UVLO, OTP, soft-start, adjustable hiccup current limit and short-circuit protection ▪ PGOOD
XR79206		6	3 to 40	0.6 to 13.2	400 to 800	95	10 x 10			
XR79103		3	3 to 22	0.6 to 5.5	600 to 800	95	6 x 6			
XR79106		6	3 to 22	0.6 to 5.5	600 to 800	95	8 x 8			
XR79110		10	3 to 22	0.6 to 5.5	400 to 800	96	10 x 10			
XR79115		15	3 to 22	0.6 to 5.5	400 to 600	96	12 x 12			
XR79120		20	3 to 22	0.6 to 5.5	400 to 600	93	12 x 14			
MxL7204	2	4	4.5 to 20	0.6 to 5.0	250 to 780	93	15 x 15	2.82	LGA	<ul style="list-style-type: none"> ▪ PFM ▪ Adjustable frequency ▪ UVLO, OTP, soft-start, and over current/over voltage/short-circuit protection ▪ Frequency synchronization ▪ PGOOD

AEC-Q100 Qualified Step-Down Switching Regulators

This family of synchronous step-down regulators combine the controller, drivers, bootstrap diode and MOSFETs in a single package for point-of-load supplies well suited for automotive applications.

Applications

- Automotive infotainment
- Advanced Driver Assistance Systems (ADAS)
- GPS / Navigation systems
- Event data recorders
- Automotive systems

Part Number	Output Current (A)	Frequency (kHz)	Operating Voltage (V)		Output Voltage	Output Voltage Range (V)		Accuracy (%)	Efficiency (%)	Package (mm)	Features
			Min	Max		Min	Max				
XR76203-Q	3	100 to 800	3	40	Adj.	0.6	30	0.5	95	5x5 QFN	<ul style="list-style-type: none"> ▪ AEC-Q100 Qualified Automotive ▪ Patented COT control ▪ UVLO, OTP, soft-start, hiccup, PGOOD ▪ Current limit and short protection
XR76205-Q	5								96		
XR76208-Q	8								96		

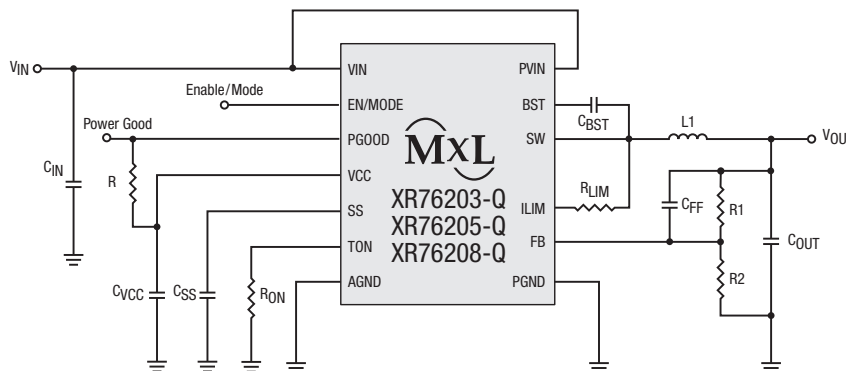

3A, 5A, 8A Step-Down Regulator

Step-Down Regulators >20V

Exar's family of synchronous and non-synchronous step-down regulators provides a fully integrated single-chip solution for Point-of-Load (POL) applications with high current output requirements. With high input voltage range and operating switching frequency options, these regulators fit in a wide range of applications and power architectures by enabling step-down DC/DC conversions from various intermediate power bus levels and providing a highly efficient and high performing solution in the most compact footprint.

Applications

- Distributed power architectures
- Point-of-Load (POL) converters
- Point-of-Load (POL) modules
- FPGAs, DSPs and processor power supplies

Part Number	Output Current (A)	Frequency (kHz)	Operating Voltage (V)		Output Voltage	Output Voltage Range (V)		Accuracy (%)	Efficiency (%)	Package (mm)	Features
			Min	Max		Min	Max				
XR76203	3	100 to 800	3	40	Adj.	0.6	30	0.5	95	5 x 5 QFN	<ul style="list-style-type: none"> ▪ Patented COT control ▪ UVLO, OTP, soft-start, hiccup, PGOOD ▪ Current limit and short protection
XR76205	5										
XR76208	8										
SP7650	3	300	2.5	28	Adj.	0.8	27	1	95	7 x 4 DFN	<ul style="list-style-type: none"> ▪ Synchronous ▪ UVLO, OTP, soft-start ▪ Short-circuit protection/auto-restart
SP7652	6	600	2.5	28	Adj.	0.8	27	1	92	7 x 4 DFN	<ul style="list-style-type: none"> ▪ Synchronous ▪ UVLO, OTP, soft-start ▪ Short-circuit protection/auto-restart
SP7662/ XRP7662	12	300	3	22	Adj.	0.8	20.2	1	93	7 x 4 DFN	<ul style="list-style-type: none"> ▪ Synchronous ▪ UVLO, OTP, soft-start, current limiting ▪ Short-circuit protection/auto-restart
XR76108	8	200 to 800	3	22	Adj.	0.6	18	0.5	96	5 x 5 QFN	<ul style="list-style-type: none"> ▪ Patented COT control ▪ UVLO, OTP, soft-start, hiccup, PGOOD ▪ Current limit and short protection
XR76112	12										
XR76115	15										
XR76117	15	200 to 800	4.5	22	Adj.	0.6	18	0.5	97	5 x 6 QFN	<ul style="list-style-type: none"> ▪ Patented COT control ▪ UVLO, OTP, soft-start, hiccup, PGOOD ▪ Current limit and short protection
XR76121	20	200 to 800	4.5	22	Adj.	0.6	18	0.5	97	5 x 6 QFN	<ul style="list-style-type: none"> ▪ Patented COT control ▪ UVLO, OTP, soft-start, hiccup, PGOOD ▪ Current limit and short protection
SP7651	3	900	2.5	20	Adj.	0.8	19	1	92	7 x 4 DFN	<ul style="list-style-type: none"> ▪ Synchronous ▪ UVLO, OTP, soft-start ▪ Short-circuit protection/auto-restart

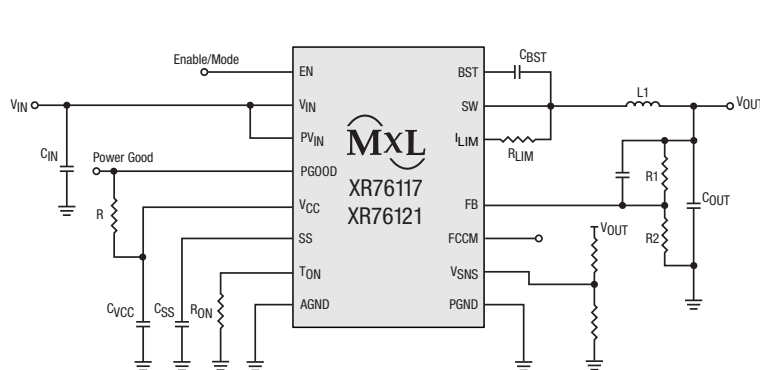

15A and 20A Step-Down Regulator

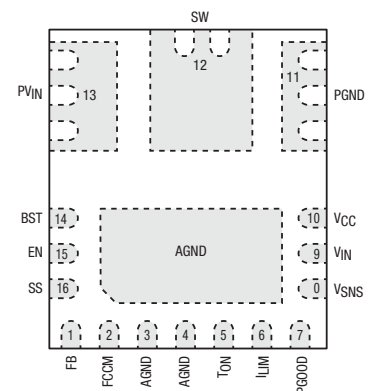

XR76121 Pin Assignment

Step-Down Regulators

Step-down regulators, also known as buck regulators, are used to lower the input voltage to the desired output level with higher efficiency than an LDO. A step-down regulator integrates power FET ICs, providing a monolithic power converter.

Applications

- Distributed power architectures
- Point-of-Load (POL) converters
- Point-of-Load (POL) modules
- FPGAs, DSPs and processor power supplies

Part Number	Ch.	Output Current	Frequency Mode (MHz)	Operating Voltage (V)		Output Voltage	Output Voltage Range (V)		Quiescent Current (µA)	Efficiency (%)	Package	Features
				Min	Max		Min	Max				
SP6669	1	600mA	1.5	2.5	5.5	Adj.	0.6	5	200	95	SOT23-5	<ul style="list-style-type: none"> ▪ Synchronous ▪ Enable pin ▪ Pulse skipping at light load ▪ Over temperature protection
SP6654	1	800mA	PFM	2.7	5.5	Adj.	0.8	5	20	98	DFN-10	<ul style="list-style-type: none"> ▪ Synchronous ▪ Enable pin ▪ Power good indicator ▪ Adjustable UVLO, over temperature protection
SP6652	1	1A	1.4	2.7	5.5	Adj.	0.75	5	1mA	97	MSOP-10	<ul style="list-style-type: none"> ▪ Synchronous ▪ Enable pin, soft-start ▪ External clock synchronization ▪ Overcurrent and over temperature protection
XRP6658	1	1A	1.5	2.5	5.5	Adj.	0.6	5	15	97	SOT23-5	<ul style="list-style-type: none"> ▪ Synchronous ▪ Light load efficiency, PFM and PWM mode ▪ Enable pin ▪ UVLO and over temperature protection
SP34063	1	Adj. <1.5A	0.11	3	36	Adj.	1	27	4mA	80	NSOIC-8	<ul style="list-style-type: none"> ▪ Can be implemented in buck, boost or inverting topologies
XRP6657	1	1.5A	1.3	2.5	5.5	Adj.	0.6	5	240	95	DFN-6	<ul style="list-style-type: none"> ▪ Synchronous ▪ Enable pin ▪ Pulse skipping at light load ▪ Over temperature protection
XRP7659	1	1.5A	1.4	4.5	18	Adj.	0.81	15	800	92	SOT23-6	<ul style="list-style-type: none"> ▪ Non synchronous ▪ Enable pin, soft-start ▪ Internal compensation ▪ Overcurrent, over temperature and UVLO protection
XRP7664	1	2A	0.3	4.5	18	Adj.	0.925	16	1.2mA	95	SOIC-8	<ul style="list-style-type: none"> ▪ Synchronous ▪ UVLO, OTP, soft-start ▪ Light load efficiency and PWM mode ▪ Overcurrent and output overvoltage protection
XRP6670	1	3A	Prog. 0.3 to 2.5	2.6	5.5	Adj.	0.8	5	460	95	DFN-10	<ul style="list-style-type: none"> ▪ Synchronous, programmable frequency ▪ Enable pin, Power Good flag ▪ OTP, OCP and UVLO protection

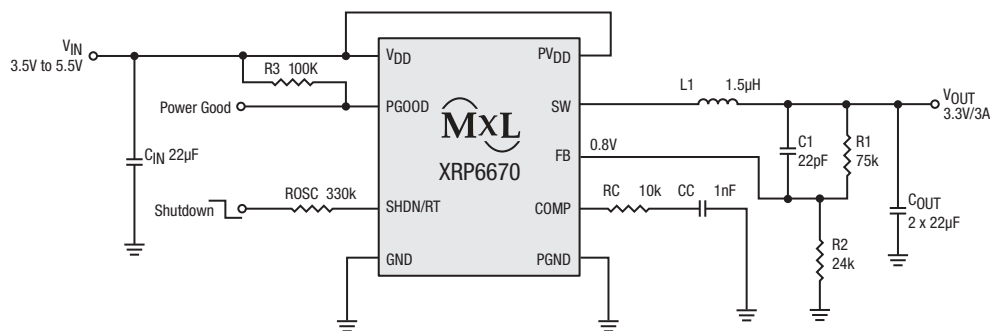

3A Synchronous Step-Down Regulator

Part Number	Ch.	Output Current	Frequency Mode (MHz)	Operating Voltage (V)		Output Voltage	Output Voltage Range (V)		Quiescent Current (μ A)	Efficiency (%)	Package	Features
				Min	Max		Min	Max				
XRP7665	1	3A	0.34	4.5	18	Adj.	0.925	16	1.2mA	95	HSOIC-8	<ul style="list-style-type: none"> Synchronous UVLO, OTP, soft-start Light load efficiency, PFM and PWM mode Overcurrent and output overvoltage protection
XRP7675	1	3A	0.34	4.5	18	Adj.	0.925	16	1.2mA	95	HSOIC-8	<ul style="list-style-type: none"> Synchronous UVLO, OTP, soft-start Light load efficiency, PFM and PWM mode Overcurrent and output overvoltage protection
XRP6668	2	1A/1A	1.5	2.5	5.5	Adj.	0.6	5	30	97	NSOIC-8	<ul style="list-style-type: none"> Synchronous Light load efficiency, PFM and PWM mode Individual enable pin UVLO and over temperature protection
XR77103-A1R0	3	2A	1	4.5	14	Adj.	0.8	6	2.8mA	93	TQFN-32	<ul style="list-style-type: none"> Synchronous UVLO, OTP, soft-start Light load efficiency, PSM and PWM mode Overcurrent and output overvoltage protection
XR77103-AOR5	3	2A	0.5	4.5	14	Adj.	0.8	6	2.6mA	93	TQFN-32	<ul style="list-style-type: none"> Synchronous UVLO, OTP, soft-start Light load efficiency, PSM and PWM mode Overcurrent and output overvoltage protection

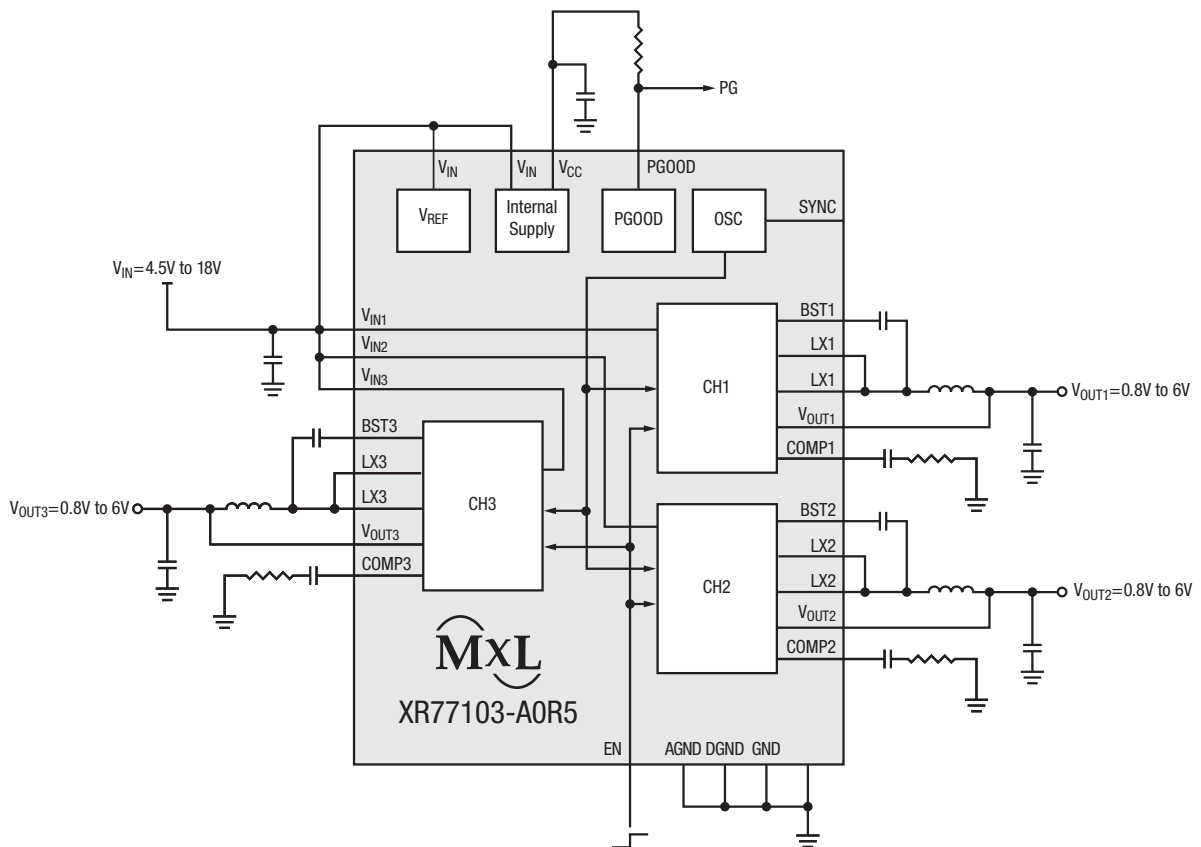

3-Output Synchronous Buck Regulator

Step-Up Regulators

Step-up regulators, also known as boost regulators, are used to step up an input voltage to the desired higher output level. They are typically used in portable equipment where the power supply is provided by a battery.

Applications

- Handheld and portable equipment
- Bias supplies

Part Number	Output Current	Operating Voltage (V)		Startup Voltage (V)	Output Voltage	Output Voltage Range (V)		Quiescent Current (µA)	Efficiency (%)	Package	Features
		Min	Max			Min	Max				
SP6641A	100mA	0.9	4.5	0.85	Fixed	3.3		10	87	SOT23-5	<ul style="list-style-type: none"> ▪ Non synchronous ▪ Enable pin ▪ Current limiting
					Fixed	5					
SP6661	200mA	1.5	5.3	n/a	Inverter	-5	-1.5	3mA	89	SOIC-8 MSOP-8	<ul style="list-style-type: none"> ▪ Charge pump topology ▪ Selectable oscillator ▪ External oscillator input
		2.5	5.3		Doubler	5	10		94		
SP6648	400mA	0.7	4.5	0.85	Adj.	2.5	5.5	13	94	MSOP-10	<ul style="list-style-type: none"> ▪ Synchronous ▪ Enable pin ▪ Programmable low battery detection ▪ Undervoltage lockout protection
SP6641B	500mA	0.9	4.5	0.85	Fixed	3.3		10	87	SOT23-5	<ul style="list-style-type: none"> ▪ Non synchronous ▪ Enable pin ▪ Current limiting
					Fixed	5					
SP34063	Adj. <1.5A	3	36	n/a	Adj.	1	27	4mA	80	NSOIC-8	<ul style="list-style-type: none"> ▪ Can be implemented in buck, boost or inverting topologies

Advanced DrMOS

This integrated power stage contains a synchronous buck gate driver packaged with both half bridge MOSFETs. Also known as DrMOS (Driver plus MOSFETs), this package design provides very low thermal impedance and minimizes parasitic inductances resulting in excellent EMI performance.

Applications

- Servers
- Networking equipment
- Industrial PC

Part Number	I _{out} (A)	V _{IN} MIN (V)	V _{IN} MAX (V)	V _{OUT} MAX (V)	Minimum On-Time (ns)	Switching Frequency (kHz)	Efficiency (%) [V _{IN} =12V, V _{OUT} = 1V, full load, 600kHz]	Junction Temp Range (°C)	Package	Features
XR78021	20A	4.5	17	3.3	30	1500	84	-40 to 125	QFN	<ul style="list-style-type: none"> ▪ UVLO, TMON, IMON

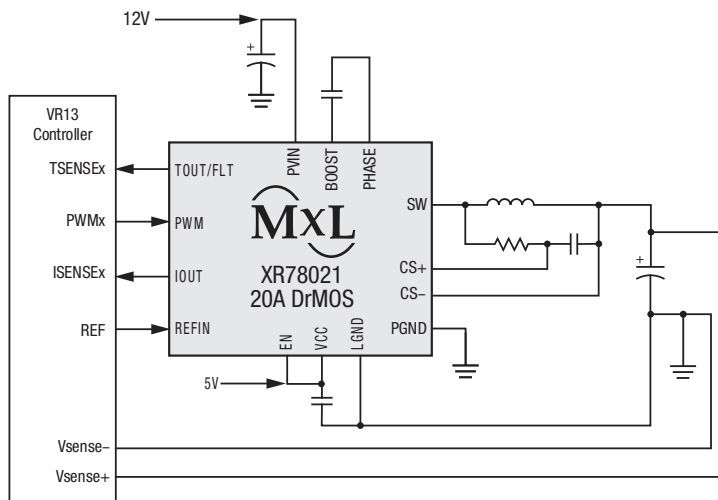

XR78021 Typical Application

Switching Controllers

Switching controllers, also known as buck controllers or Step-down, are the basic building blocks for high efficiency and high power point-of-loads. Step-down controllers allow maximum flexibility and customization for high performance conversions.

Applications

- Distributed power architectures
- Point-of-Load (POL) converters/modules
- Set-top boxes

Part Number	Rec. Output Current (A)	Operating Voltage (V)		Min. Output Voltage (V)	Quiescent Current (μ A)	Frequency (kHz)	Efficiency (%)	Package	Features
		Min	Max						
XR75100	<20	3	40	0.6	700	200 to 800	96	QFN-16	<ul style="list-style-type: none"> ▪ Proprietary emulated current mode constant on-time architecture ▪ No external compensation ▪ Adjustable frequency ▪ Precision enable, soft-start, force PWM ▪ Adjustable temperature compensated current limit
XRP6124	<5	3	18	1.2	500	200 to 1000	92	SOT23-5	<ul style="list-style-type: none"> ▪ Non synchronous, 500ns constant on-time ▪ Enable pin, soft-start ▪ UVLO and output short-circuit protection
XRP6124HV		4.5	30						
SP6134H	<15	3	28	0.8	1.5mA	600	94	MSOP-10	<ul style="list-style-type: none"> ▪ Synchronous voltage mode PWM ▪ Programmable soft-start ▪ UVLO, over temperature and output short-circuit protection
SP6132H	<20	3	28			300	95		
SP6133	<30	3	24	0.8	1.5mA	300	95	QFN-16	<ul style="list-style-type: none"> ▪ Synchronous voltage mode PWM ▪ Enable pin, Power Good flag indicator ▪ Programmable soft-start, current limiting ▪ UVLO, over temperature and output short-circuit protection
XRP6141	<35	3	22	0.6	700	200 to 800	95	QFN-16	<ul style="list-style-type: none"> ▪ Proprietary emulated current mode constant on-time architecture ▪ No external compensation ▪ Adjustable frequency ▪ Precision enable, soft-start, force PWM ▪ Adjustable temperature compensated current limit
SP6123	<10	3	5.5	0.8	500	300	95	NSOIC-8	<ul style="list-style-type: none"> ▪ Synchronous voltage mode PWM ▪ Soft-start, on/off mode ▪ UVLO and overcurrent protection
SP6128A	<10	3	5.5	0.8	500	300	95	TSSOP-14	<ul style="list-style-type: none"> ▪ Synchronous voltage mode PWM ▪ Soft-start, on/off mode ▪ UVLO and overcurrent protection

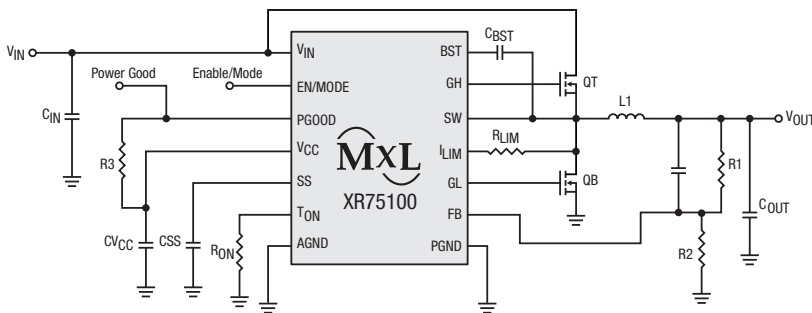

40V Synchronous Step-Down COT Controller

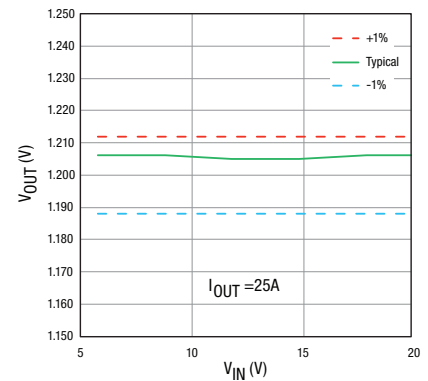

XR75100 Line Regulation

DDR Termination

Part Number	Output Current	Output Voltage	Accuracy (%)	Operating Voltage (V)		Quiescent Current (µA)	Package	Features
				Min	Max			
XRP2997	2A	Adjustable	1	1.1	5.5	2	HSOIC-8	<ul style="list-style-type: none"> ▪ DDR I/II/III/IV bus termination ▪ Over temperature protection ▪ Overcurrent protection

Linear Regulators

Part Number	Output Current (mA)	Output Voltage (V)	Accuracy (%)	Operating Voltage (V)		Quiescent Current (mA)	Package	Features
				Min	Max			
SP78L05	100	5	5	7.5	18	1.5	NSOIC-8	<ul style="list-style-type: none"> ▪ Over temperature protection ▪ Short-circuit protection

LDOs

Exar manufactures a broad line of low dropout linear regulators (LDO). The simplest and lowest cost technique for stepping down a DC voltage, LDOs offer a quiet, well-regulated DC voltage supply with excellent transient response.

Applications

- Portable equipment
- Handheld devices
- Mobile phones and PDAs
- Medical and industrial instrumentation

Part Number	Output Current	Output Voltage (V)	V _{OUT} (V) Adjustable		Accuracy (%)	Typical Dropout Voltage (mV)	Operating Voltage (V)		Quiescent Current (μA)	Package	Features
			Min	Max			Min	Max			
SP6213	100mA	3.3			2.5	250	2.5	7	65	SC70-5	<ul style="list-style-type: none"> ▪ Enable pin ▪ Current limiting and thermal protection
LP2951	100mA	3.3, 5			0.5, 1	380	2.4	30	150	NSOIC-8	<ul style="list-style-type: none"> ▪ Enable pin ▪ Output error flag indicator ▪ Current limiting and thermal protection
SPX5205	150mA	Adj., 1.8, 3, 3.3, 5	1.24	15.725	1	210	2.5	16	70	SOT23-5	<ul style="list-style-type: none"> ▪ Reverse battery protection ▪ Current limiting and thermal protection
SP6201	200mA	1.8, 3, 3.3, 5			2	320	2.5	7	28	SOT23-5	<ul style="list-style-type: none"> ▪ Enable pin ▪ Power good indicator
SP6260	200mA	3.3			2	200	2	6	25	SOT23-5	<ul style="list-style-type: none"> ▪ Low noise: 30μV_{RMS}, no bypass cap needed ▪ Enable pin ▪ Current limiting and thermal protection
SPX2954	250mA	5			0.5	310	2.4	30	150	NSOIC-8 SOT223-3	<ul style="list-style-type: none"> ▪ Enable pin ▪ Output error flag indicator ▪ Current limiting and thermal protection
		3.3, 5			1					NSOIC-8 SOT223-3	
SP6203	300mA	2.8			2	180	2.7	6	45	SOT23-5	<ul style="list-style-type: none"> ▪ Low noise: 12μV_{RMS} ▪ Enable pin ▪ Current limiting and thermal protection
SPX2945	400mA	3.3			0.5, 1	420	4.1	30	100	SOT223-3	<ul style="list-style-type: none"> ▪ Enable pin ▪ Output error flag indicator ▪ Current limiting and thermal protection
SP6205	500mA	Adj., 3, 3.3	2.7	5.7	2	300	2.7	6	45	SOT23-5	<ul style="list-style-type: none"> ▪ Low noise: 12μV_{RMS} (fixed voltage version) ▪ Enable pin ▪ Current limiting ▪ Over temperature protection
		Adj.								DFN-8	
SPX3819	500mA	Adj., 1.2, 1.5, 1.8, 2.5, 3, 3.3, 5	1.235	15.45	1	340	2.5	16	90	SOT23-5	<ul style="list-style-type: none"> ▪ Enable pin ▪ Reverse battery protection ▪ Current limiting and thermal protection
		Adj., 1.2								DFN-8	
		Adj., 5								NSOIC-8	
SPX1117	800mA	Adj., 1.5, 1.8, 2.5, 3.3, 5	1.25	15	1	1100	2.6	15	5mA	SOT223-3	<ul style="list-style-type: none"> ▪ Current limiting and thermal protection
SPX2941	1A	Adj.	1.24	15.45	3	280	3	16	12mA	TO263-5	<ul style="list-style-type: none"> ▪ Enable pin ▪ Reverse battery protection ▪ Current limiting and thermal protection
SPX3940A	1A	3.3, 5			1	280	3.1	16	18mA	SOT223-3	<ul style="list-style-type: none"> ▪ Reverse battery protection ▪ Current limiting and thermal protection
		3.3			2					TO263-3	
SPX3940	1A	2.5, 5			2					SOT223-3	
		3.3								TO263-3	
SPX2815	1.5A	Adj., 3.3	1.25	8.8	1, 2	1100	2.5	10	4mA	TO263-3	<ul style="list-style-type: none"> ▪ Current limiting and thermal protection

Part Number	Output Current	Output Voltage (V)	V _{OUT} (V) Adjustable		Accuracy (%)	Typical Dropout Voltage (mV)	Operating Voltage (V)		Quiescent Current (μA)	Package	Features
			Min	Max			Min	Max			
SPX29150	1.5A	3.3, 5.0			1	390	2.5	16	12mA	TO263-3	<ul style="list-style-type: none"> Reverse battery protection Current limiting and thermal protection
SPX29152	1.5A	Adj.	1.25	15.4	1	390	2.5	16	12mA	TO263-5	<ul style="list-style-type: none"> Enable pin Current limiting and thermal protection
XRP6272	2A	Adj., 5	0.7	5.3	2	550	1.8	6	30	TO252-5 HSOIC-8	<ul style="list-style-type: none"> Enable and power good functions Current limiting and thermal protection
SPX1582	3A	Adj.	1.25	6	2	400	1.8	5.5	5mA	TO263-5	<ul style="list-style-type: none"> Enable pin External sense pin Current limiting and thermal protection
SPX1587	3A	Adj., 2.5, 3.3	1.25	8.8	1	1100	2.8	10	4mA	TO263-3	<ul style="list-style-type: none"> Current limiting Over temperature protection
SPX29300	3A	2.5, 3.3, 5			1	600	2.5	16	37mA	TO263-3	<ul style="list-style-type: none"> Current limiting and thermal protection Reverse battery protection
SPX29301	3A	5			1	600	4	16	37mA	TO263-5	<ul style="list-style-type: none"> Enable pin Output error flag indicator Current limiting and thermal protection
SPX29302	3A	Adj.	1.25	16	1	600	2.8	16	37mA	TO263-5	<ul style="list-style-type: none"> Enable pin Current limiting and thermal protection Reverse battery protection

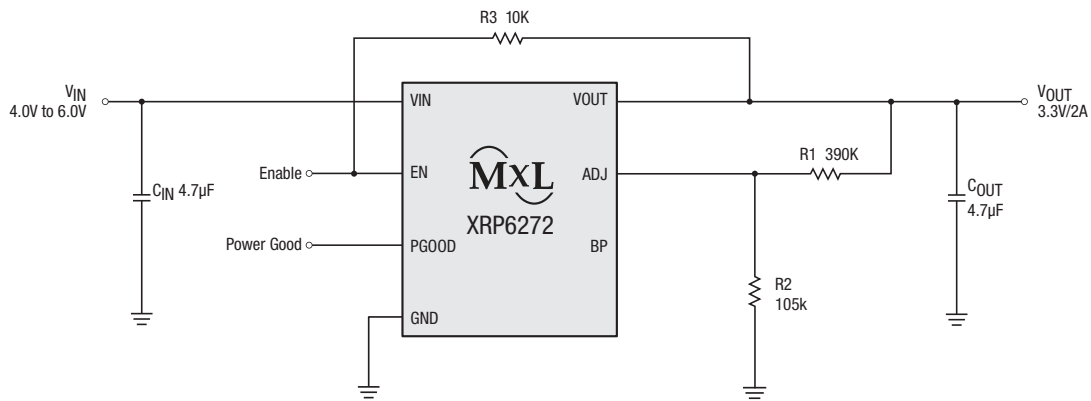

XRP6272 Typical Application

Power Switches

Power switches provide low loss, high efficiency power management, monitoring and fault handling capabilities for any power distribution network. Use of these compact devices results in safer, more stable and more reliable interconnecting systems.

Applications

- USB V_{BUS} power management
- Set-top boxes
- USB peripherals
- Battery charger circuits

Part Number	Channel(s)	Output Current	Current Limit	Operating Voltage (V)		Quiescent Current (μ A)	Package	Features
				Min	Max			
SP2525A	1	500mA	850mA	3	5.5	75	NSOIC-8	<ul style="list-style-type: none"> ▪ Active high or low enable pin(s) ▪ USB 2.0 compliant ▪ Current limiting ▪ Fault flag indicator(s) ▪ Over temperature protection ▪ Undervoltage lock out protection
SP2526A	2	500mA	850mA	3	5.5	110	NSOIC-8	
SP619	1	600mA	800mA	2.5	5.5	350	SOT23-6	<ul style="list-style-type: none"> ▪ Active high enable pin ▪ Current limiting ▪ Short-circuit protection ▪ Over temperature protection
XRP2526	2	900mA	1.15A	1.8	5.5	65	NSOIC-8	<ul style="list-style-type: none"> ▪ Active high or low enable pin(s) ▪ USB 3.0 compliant ▪ Current limiting ▪ Blanking fault flag indicator(s) ▪ Over temperature/reverse current protection ▪ Undervoltage lock out protection

Voltage References

Voltage references provide a precise and stable output voltage over a wide range of conditions such as input voltage fluctuations and/or operating temperature change. These devices guarantee system accuracy and performance.

Applications

- Power supplies
- Mother boards
- Medical and industrial instrumentation

Part Number	V_{REF} (V)	Accuracy (%)	Operating Current (mA)	Max Operating Voltage (V)	I_{REF} (μ A)	Operating Temperature Range ($^{\circ}$ C)	Temperature Coefficient (ppm/ $^{\circ}$ C)	Package	Features
SPX385	2.5 5	1	0.01 to 20	–	–	-40 to 85	80	SOT23-3	<ul style="list-style-type: none"> ▪ Shunt reference ▪ Replacement for LM285/385
SPX431A	2.5	0.5	1 to 150	36	0.7	-40 to 125	30	SOT89-3	<ul style="list-style-type: none"> ▪ V_{REF} adjustable up to 36V ▪ Replaces TL431 and AS431
SPX431L	2.5	1	1 to 100	20	0.7	0 to 105	30	SOT89-3	<ul style="list-style-type: none"> ▪ V_{REF} adjustable up to 20V ▪ Replaces TL431 and AS431
SPX432	1.24	1	1 to 80	15	3	0 to 105	50	SOT23-3	<ul style="list-style-type: none"> ▪ V_{REF} adjustable to 15V ▪ Replaces TLV431 and AS432
SPX1431	2.5	0.4	1 to 150	36	0.7	-55 to 125	30	SOT89-3	<ul style="list-style-type: none"> ▪ V_{REF} adjustable up to 36V ▪ Replaces TL1431
SPX2431	2.5	0.5, 1	1 to 100	20	0.7	0 to 105	30	SOT23-3	<ul style="list-style-type: none"> ▪ V_{REF} adjustable up to 20V ▪ Replaces TL2431 and AS2431

Supervisors

Supervisory circuits ensure safe operating conditions for microprocessor and memory-based systems. By monitoring one or more system supplies, supervisory circuits provide basic protection such as power-on reset as well as fault monitoring during power-up, power down and undervoltage (brownout) conditions. Additional functions typically include a watchdog timer, a manual reset and battery backup supply switching.

Applications

- Mother boards
- Telecom and datacom equipment
- Medical and industrial instrumentation

Part Number	Channel(s)	Reset Threshold (V)	Reset Accuracy	Reset Active	Operating Voltage(V)		Quiescent Current (µA)	Package	Features
					Min	Max			
SP690A	1	4.65	125mV	Low	1	5.5	35	NSOIC-8	<ul style="list-style-type: none"> ▪ Watchdog timer ▪ Back-up battery switchover ▪ Power fail, low battery indicator
SP690S	1	2.925	75mV	Low	1	5.5	25	NSOIC-8	<ul style="list-style-type: none"> ▪ Watchdog timer ▪ Back-up battery switchover ▪ Power fail, low battery indicator
SP691	1	4.65	125mV	Low/High	1	5.5	35	NSOIC-16 WSOIC-16	<ul style="list-style-type: none"> ▪ Programmable watchdog timer ▪ Back-up battery switchover ▪ Power fail, low battery indicator ▪ Chip enable gating
SP705	1	4.65	150mV	Low	1.1	5.5	40	NSOIC-8	<ul style="list-style-type: none"> ▪ Watchdog timer ▪ Power fail, low battery indicator ▪ Manual reset
SP706	1	4.40	150mV	Low	1.1	5.5	40	NSOIC-8	<ul style="list-style-type: none"> ▪ Watchdog timer ▪ Power fail, low battery indicator ▪ Manual reset
SP706R	1	2.63	80mV	Low	1.1	5.5	25	NSOIC-8	<ul style="list-style-type: none"> ▪ Watchdog timer ▪ Power fail, low battery indicator ▪ Manual reset
SP706S	1	2.93	80mV	Low	1.1	5.5	25	NSOIC-8 MSOP-8	<ul style="list-style-type: none"> ▪ Watchdog timer ▪ Power fail, low battery indicator ▪ Manual reset
SP706T	1	3.08	80mV	Low	1.1	5.5	25	NSOIC-8 MSOP-8	<ul style="list-style-type: none"> ▪ Watchdog timer ▪ Power fail, low battery indicator ▪ Manual reset
SP707	1	4.65	150mV	Low/High	1.1	5.5	40	NSOIC-8	<ul style="list-style-type: none"> ▪ Power fail, low battery indicator ▪ Manual reset
SP708	1	4.40	150mV	Low/High	1.1	5.5	40	NSOIC-8	<ul style="list-style-type: none"> ▪ Power fail, low battery indicator ▪ Manual reset
SP708S	1	2.93	80mV	Low/High	1.1	5.5	25	NSOIC-8 MSOP-8	<ul style="list-style-type: none"> ▪ Power fail, low battery indicator ▪ Manual reset
SP708T	1	3.08	80mV	Low/High	1.1	5.5	25	NSOIC-8	<ul style="list-style-type: none"> ▪ Power fail, low battery indicator ▪ Manual reset
SP809	1	2.3, 2.6, 2.9	1.50%	Low	0.9	6	1	SOT23-3	<ul style="list-style-type: none"> ▪ 140ms reset pulse width ▪ Push-pull output
SP809N	1	3.1	1.50%	Low	0.9	6	1	SOT23-3	<ul style="list-style-type: none"> ▪ 140ms reset pulse width ▪ Open drain output
SP813	1	4.65	150mV	High	1.1	5.5	40	NSOIC-8	<ul style="list-style-type: none"> ▪ Watchdog timer ▪ Manual reset

AC Step Drivers

Exar is the world leader in AC step driver solutions for LED bulbs, tubes, troffers, downlights and decorative LED applications. Our patented distributed architecture eliminates the need for magnetics, MOVs and electrolytic capacitors providing robust, cost effective and extremely small solutions with low flicker, high power factor and low THD.

Applications

- Downlight
- High bay
- Specialty
- Architectural

Part Number	Steps	Max Voltage (V)	I _{OUT} MAX (mA)	Power Line Regulation	Dimming	Package	Features
XR46203	2	78	180	Y	Y; Triac	TDFN-8	<ul style="list-style-type: none"> ▪ 2-step integrated driver ▪ Better thermal performance ▪ Built in thermal foldback and VIN pin clamp
XR46110	1	78	180	Y	Y; Triac	TDFN-6	<ul style="list-style-type: none"> ▪ 1-step driver ▪ Improved line regulation ▪ Built in thermal foldback and VIN pin clamp
XR46073	2	78	180	Y	Y; Triac	TDFN-6	<ul style="list-style-type: none"> ▪ 2-step integrated driver ▪ Improved line regulation ▪ Built in thermal foldback and VIN pin clamp
XR46050	2	78	180	N	Y; Triac	TDFN-6	<ul style="list-style-type: none"> ▪ 2-step integrated driver ▪ Smallest footprint solution ▪ Built in thermal foldback and VIN pin clamp
XR46084	1	80	130	N	Y; Triac	TDFN-6, SOT-89-5	<ul style="list-style-type: none"> ▪ 1-step driver ▪ For use in non-dimmable applications
XR46083	1	80	130	N	N	TDFN-6, SOT-89-5	<ul style="list-style-type: none"> ▪ 1-step driver ▪ For use in non-dimmable applications
XR46010	1	80	60	-	Y; Improved Triac	SOT23-3	<ul style="list-style-type: none"> ▪ Improves TRIAC dimmable performance when used with other AC step drivers
XR46014	1	80	250	N	Y; Triac	SOT223-3	<ul style="list-style-type: none"> ▪ 1-step driver ▪ For use in dimmable applications and full balance systems
XR46000	-	600	-	-	-	SOT223-3	<ul style="list-style-type: none"> ▪ N-Channel Power MOSFET ▪ Use with all Exar step driver solutions ▪ Provides > 750V native surge capability
XR46701	1	40	-	Y	Y; Analog/PWM	TDFN-8, MSOP-8	<ul style="list-style-type: none"> ▪ Supports dual voltage range lighting engines and low power smart lighting
XR46004-Q	1	75	600	N	PWM	TO-252-5	<ul style="list-style-type: none"> ▪ Internal pass device

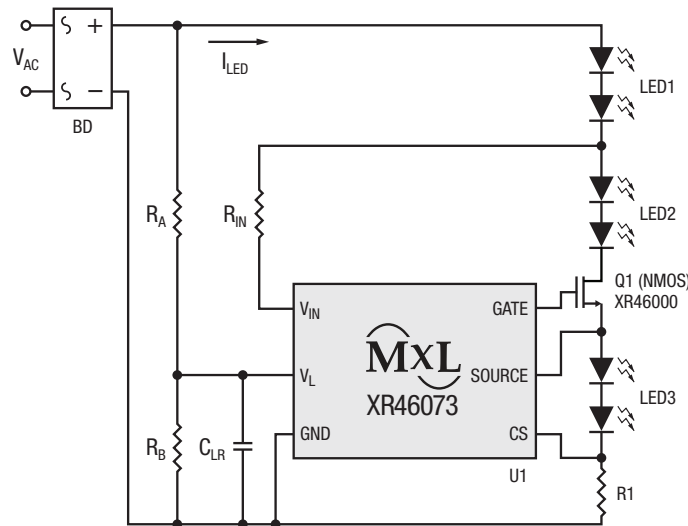

Two-Step LED Current Controller

Switching Regulators

Efficiency, performance, size and reliability are rapidly imposing LEDs as the lighting solution of choice in space-constrained portable electronic equipment as well as in architectural and accent lighting fixtures. Exar's LED lighting products offer compact and efficient solutions for line and battery-operated devices and are capable of driving multiple LEDs in various series or parallel topologies.

Applications

- General lighting and display
- Medical and industrial instrumentation
- Keypad and signage backlighting

Part Number	Ch.	Max Current/Ch.	LEDs/Ch.	Operating Voltage (V)		Ref. Voltage (mV)	Freq. (MHz)	Max Output Voltage (V)	Quiescent Current (µA)	Efficiency (%)	Package	Application	Features
				Min	Max								
XRP7613	1	1.2A	8	7	36	100	<1	36	35	95	SOIC-8	High-powered LED	<ul style="list-style-type: none"> ▪ Hysteretic PFM control ▪ Enable and soft-start functions ▪ Analog and PWM dimming ▪ Dynamic LED current thermal control
SP7685	1	1.2A	1	2.7	5.5	50	2.4	5.5	500	94	DFN-10	Flash	<ul style="list-style-type: none"> ▪ Charge pump topology ▪ Enable pin, flash/torch mode ▪ Adjustable flash current, soft-start ▪ Flash timeout protection ▪ Overvoltage, overcurrent and temperature protection
SP6686	1	400mA	1	2.7	5.5	50	2.4	5.5	500	94	DFN-10	Flash	<ul style="list-style-type: none"> ▪ Charge pump topology ▪ Enable pin, flash/torch mode ▪ Adjustable flash current, soft-start ▪ Overvoltage, overcurrent and temperature protection
SP6699	1	20mA	6	2.5	16	200	1.2	27	3.2	84	SOT23-6	Backlight	<ul style="list-style-type: none"> ▪ Integrated Schottky diode ▪ Enable pin, PWM dimming ▪ Soft-start

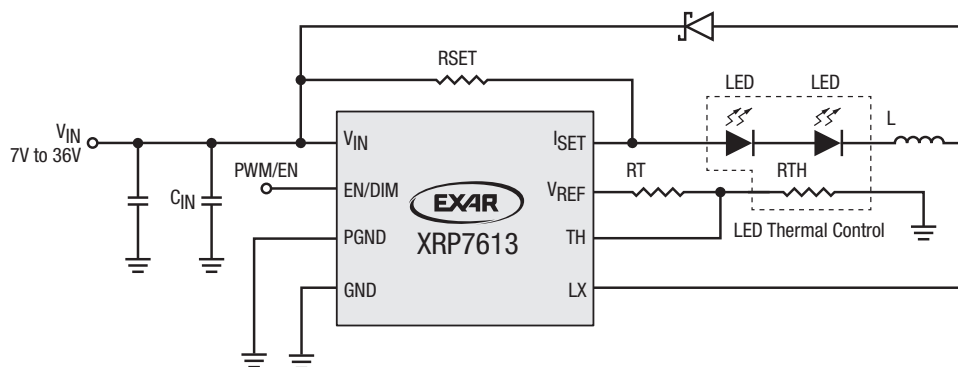

1.2A 36V Step-Down LED Driver

The content of this document is furnished for informational use only, is subject to change without notice, and should not be construed as a commitment by MaxLinear, Inc.. MaxLinear, Inc. assumes no responsibility or liability for any errors or inaccuracies that may appear in the informational content contained in this guide. Complying with all applicable copyright laws is the responsibility of the user. Without limiting the rights under copyright, no part of this document may be reproduced into, stored in, or introduced into a retrieval system, or transmitted in any form or by any means (electronic, mechanical, photocopying, recording, or otherwise), or for any purpose, without the express written permission of MaxLinear, Inc.

Maxlinear, Inc. does not recommend the use of any of its products in life support applications where the failure or malfunction of the product can reasonably be expected to cause failure of the life support system or to significantly affect its safety or effectiveness. Products are not authorized for use in such applications unless MaxLinear, Inc. receives, in writing, assurances to its satisfaction that: (a) the risk of injury or damage has been minimized; (b) the user assumes all such risks; (c) potential liability of MaxLinear, Inc. is adequately protected under the circumstances.

MaxLinear, Inc. may have patents, patent applications, trademarks, copyrights, or other intellectual property rights covering subject matter in this document. Except as expressly provided in any written license agreement from MaxLinear, Inc., the furnishing of this document does not give you any license to these patents, trademarks, copyrights, or other intellectual property.

Company and product names may be registered trademarks or trademarks of the respective owners with which they are associated.

© 2017 MaxLinear, Inc. All rights reserved



Corporate Headquarters:
5966 La Place Court
Suite 100
Carlsbad, CA 92008
Tel.: +1 (760) 692-0711
Fax: +1 (760) 444-8598
www.maxlinear.com

High Performance Analog:
1060 Rincon Circle
San Jose, California 95131 USA
Tel.: +1 (669)265-6100
Fax: +1 (669)265-6101
www.exar.com