

PIN diode Vector Modulators - Fundamentals and Drive Requirements

Rev. V4

Introduction

M/A-COM's **Chip Scale Package (CSP)** vector modulator platform offers a means of varying attenuation and phase in a single surface mount package. These vector modulators offer linear phase and minimal amplitude ripple in their bands of operation. Due to using PIN diodes as the active devices, these vector modulators have high intercept points. These vector modulators operate in tandem with a dual linearizer, MADRCC0002 that has been developed by M/A-COM.

Basic Vector Modulator Operation

The block diagram for the vector modulator is given in Figure 1. The vector modulator consists of four elements: an input quadrature hybrid, two voltage variable attenuators (four-port quadrature hybrids with both outputs terminated in PIN diodes), and an output power combiner.

One of the keys to understanding how vector modulators work is to understand that there is a phase shift of 180° when the impedance of the diodes (for a single VVA) crosses 50 ohms. For diode impedance of greater than 50 ohms, there is no phase change when the signal reflects off of the diodes. This can also be noted on the Smith Chart. Note that when the impedance of the diodes is less than 50 ohms, there is no phase shift. The following will describe the vectors in three cases. See Figure 2 for additional insight into how single vectors pass through the vector modulator.

- Case 1. If the diodes in the bottom VVA are set to an impedance of 50 ohms, the bottom VVA will be in a high loss state. The output of the top VVA will have a phase of 0° or 180°, depending on the impedance of the terminating diodes. See the "A" or "/A" labels.

- Case 2. If the diodes in the top VVA are set to an impedance of 50 ohms, the top VVA will be in a high loss state. The output of the bottom VVA will have a phase of -90° or 90°, depending on the impedance of the terminating diodes. See the "B" or "/B" labels.
- Case 3. If the output of the top VVA has a phase of 0° with a magnitude of 1, and the output of the bottom VVA has a phase of 90° with a magnitude of 1, the resultant vector will have a magnitude of 1.414 (square root of 2) at an angle of 45°.

Definition of RF Parameters

It is helpful to define some of the parameters used to specify the electrical performance of a vector modulator, so that the specifications are clearly understood. Note that this type of vector modulator is designed to have continuous phase shift over 360°.

Reference Loss: This is the minimum loss where all phases from 0° to 360° are available. This is measured at the center frequency of the specified band.

Attenuation Range: This is the attenuation (relative to the reference loss), where the performance of the vector modulator is defined. For example, if a vector modulator has an attenuation range of 10 dB, and a reference loss of 12 dB, the vector modulator will operate over an absolute loss range between 12 and 22 dB. Note that in the case of SA90-0001, the vector modulator has a higher attenuation range than the specified range, but the attenuation is difficult to control, and the phase linearity and amplitude ripple start to degrade.

Frequency Band (MHz)	Band	Model Number	Model Number of Prototype with Driver	Availability
925 - 960	GSM	MAMDCC0005	MAMDCC0005-DC000	Q2 2002
1930 - 1990	PCS	MAMDCC0002	MAMDCC0002-DC000	In Stock
2040 - 2240	UMTS	SA90-0001	SA90-0001-DC000	In Stock

Table 1. Selection Guide for Vector Modulator

**PIN diode Vector Modulators -
Fundamentals and Drive Requirements**

Rev. V4

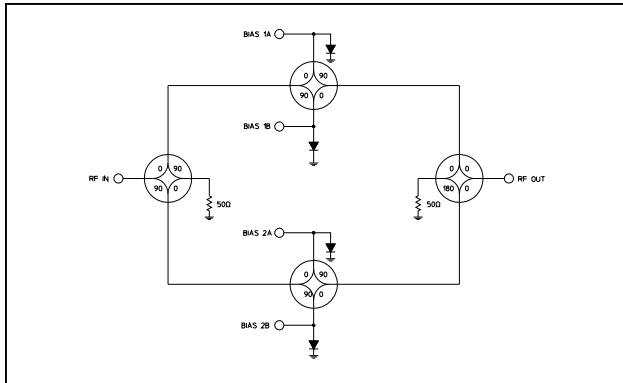

Figure 1. Block Diagram

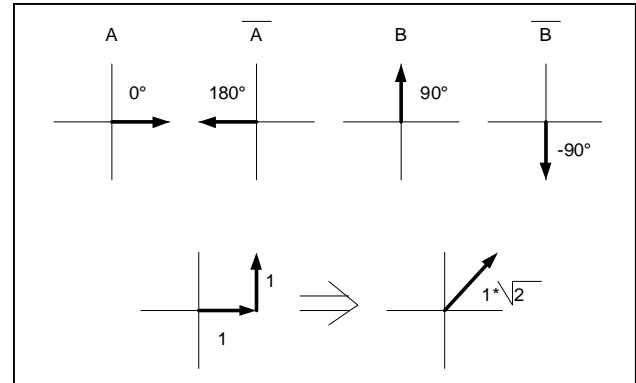

Figure 2. Summation of Vectors

Amplitude Ripple: This is one half of the peak-to-peak ripple in the specified frequency band. For example, if the minimum loss is 11.8 dB, and the maximum loss is 12.2 dB, the peak to peak ripple is 0.4 dB, so the Amplitude Ripple would be 0.2 dB.

Deviation from Linear Phase: This is a test to see how linear the phase of the vector modulator is. To find Deviation from Linear Phase, a line that best approximates the measured data points by using the method of least squares must be found. The deviation from linear phase is the difference between the calculated and measured line.

Drive Requirements for a Vector Modulator

Driving a vector modulator requires a solid understanding of the transfer function from the Bias1 and Bias2 inputs to the amplitude and phase change of the vector modulator. It should be noted that vector modulators are driven by current, due to the PIN diode construction. The following description will focus on how PIN diode vector modulators are driven by dual linearizers. A chart of the drive characteristics when driven by current will also be provided.

M/A-COM has designed a dual linearizer, MADRCC0002, so that the amplitude and phase of the vector modulators is linearized relative to the control voltages at the inputs of the linearizer. See the circuit in Figure 3 for the schematic of MADRCC0002 driving the SA90-0001 vector modulator. This same schematic also holds when driving the MAMDCC0002 and MAMDCC0005 vector modulators.

The first step is to determine the reference loss of the vector modulator. See Figure 4, which provides the transfer function of the test.

The four outer curves are found by sweeping the biases as follows:

1. Set Bias2 to 0.0V. Sweep Bias1 from 0.0 to 5.0V in 0.1V increments.
2. Keep Bias1 at 5.0V. Sweep Bias2 from 0.0 to 5.0V in 0.1V increments.
3. Keep Bias2 at 5.0V. Sweep Bias1 from 5.0 to 0.0V in 0.1V increments.
4. Keep Bias1 at 0.0V. Sweep Bias2 from 5.0 to 0.0V in 0.1V increments.

The circle that is tangent to the inside of the plot is the reference loss circle, which is about 12 dB in this example. Note that the plots in Figures 4 and 5 are the same, but the lines of different bias voltages were removed to clarify the curves that are used to find reference loss. Figures 5 and 6 use the same axes and scales. The tick marks on the axes are reflection coefficients in steps of 0.1. The equation that calculates loss from reflection coefficient is:

$$\text{Mag} = 10^{(\text{loss_in_dB}/20)}$$

Figure 5 provides a plot of insertion loss (in magnitude) and phase as the control inputs are varied in 0.5V increments from 0.0V to 5.0V. This gives a good representation of the loss and phase. However, it should be noted that this plot will vary lot to lot. The primary reason for the variation is that the resistance vs. current of PIN diodes had some lot to lot variation. Both graphs in Figure 5 have the same data. Due to the number of labels, the plot was repeated to ensure legibility.

Figure 6 is similar to Figure 5, but is a plot of insertion loss (in magnitude) and phase vs. control current.

PIN diode Vector Modulators - Fundamentals and Drive Requirements

Rev. V4

PCB Design Guidelines

The outline drawing for the vector modulator is provided in Figure 7. The recommended PC board layout is provided in Figure 8. Note that the topology of the bias components on the layout is similar to the topology of bias components on the schematic. It is important to have the inductors as close to the vector modulator as possible. If the inductors are rotated around the Smith chart, they will look like capacitors, and will not provide the high impedance to the RF signal. If the RF signal is not blocked, there can be coupling between the output ports of the 90° hybrids, which will degrade the performance of the vector modulator. The capacitors should be centered between the inductors and as close as possible to the inductors, as shown in the PC board layout.

The paddle (base) of the package is grounded to optimize the RF performance of the vector modulator. A chip scale package (CSP) was used to minimize the amount of PC board space that the end user would require. There are two RF connections (RF IN and RF OUT) and four bias connections. All of the other connections are ground. RF IN and RF OUT should be connected to 50 ohm transmission lines. It is preferred to select the PC board material so that the RF lines are less than 20 mils wide to minimize coupling from the RF lines to the bias circuit. The lines in the bias circuit should be approximately 6 mils wide to minimize cross coupling.

The recommended solder for mounting surface mount packages is Sn63 (63% Sn, 37% Pb) because it is a eutectic compound with a melting point (183°C) high enough to exceed the standard operating limit of the devices, but low enough to avoid damaging internal circuitry during proper solder reflow operations.

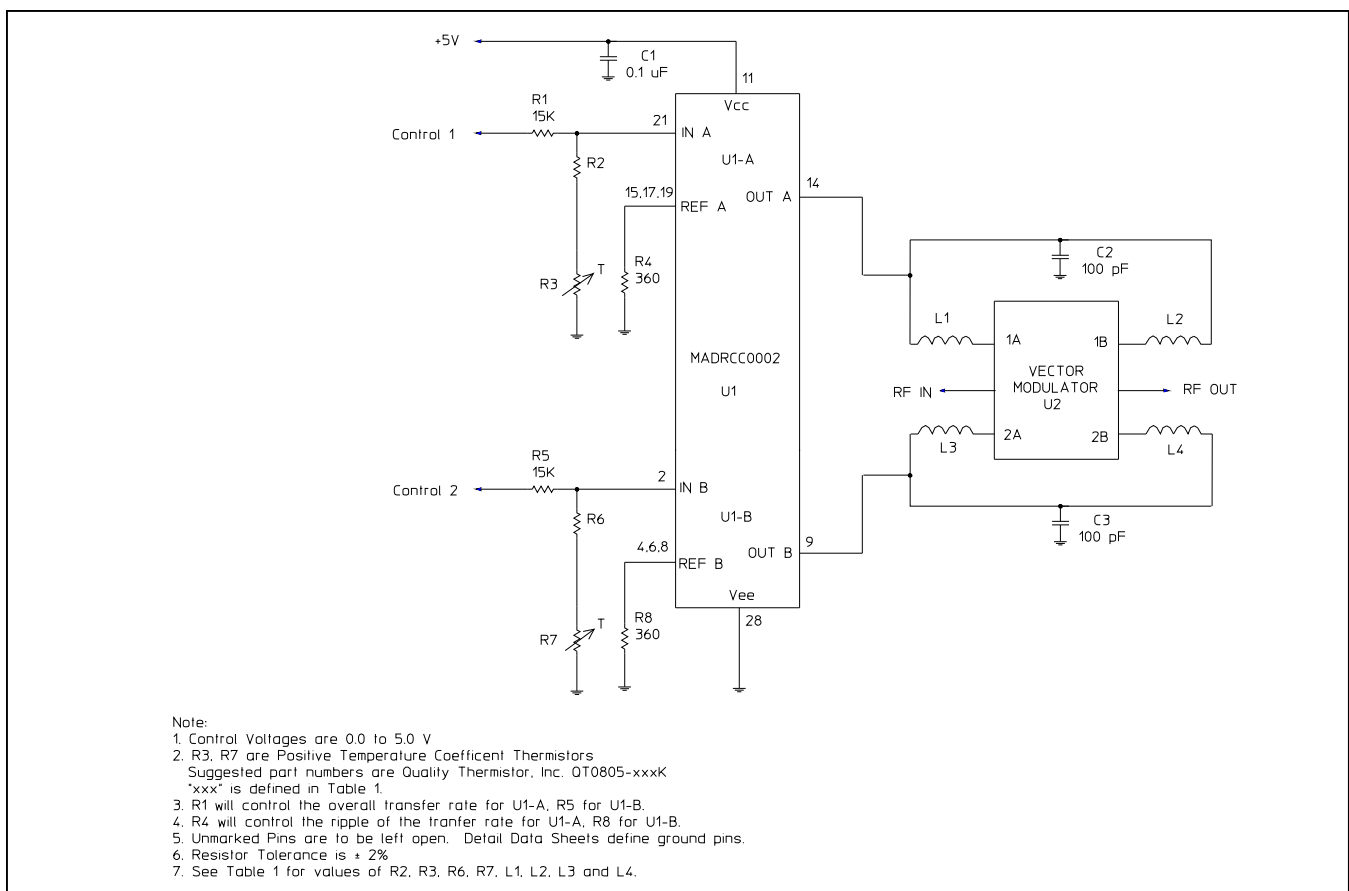

Figure 3. Schematic of Dual Linearizer Driving Vector Modulator

**PIN diode Vector Modulators -
Fundamentals and Drive Requirements**

Rev. V4

Model Number	Frequency Range (MHz)	Coilcraft P/N L1 - L4	Description of L1 - L4	Resistor Values R2, R6	Thermistor Values R3, R7	Quality Thermistor P/N for R3, R7
MAMDCC0005	925 - 960 (GSM)	0603CS-68NXJBC	Inductor, 68 nH, $\pm 5\%$	270 Ohms	750 Ohms	QT0805-751K
MAMDCC0002	1930 - 1990 (PCS)	0603CS-27NXJBC	Inductor, 27 nH, $\pm 5\%$	360 Ohms	680 Ohms	QT0805-681K
SA90-0001	2040 - 2240 (UMTS)	0603CS-27NXJBC	Inductor, 27 nH, $\pm 5\%$	270 Ohms	750 Ohms	QT0805-751K

Table 2. Selection Table for Bias Inductors

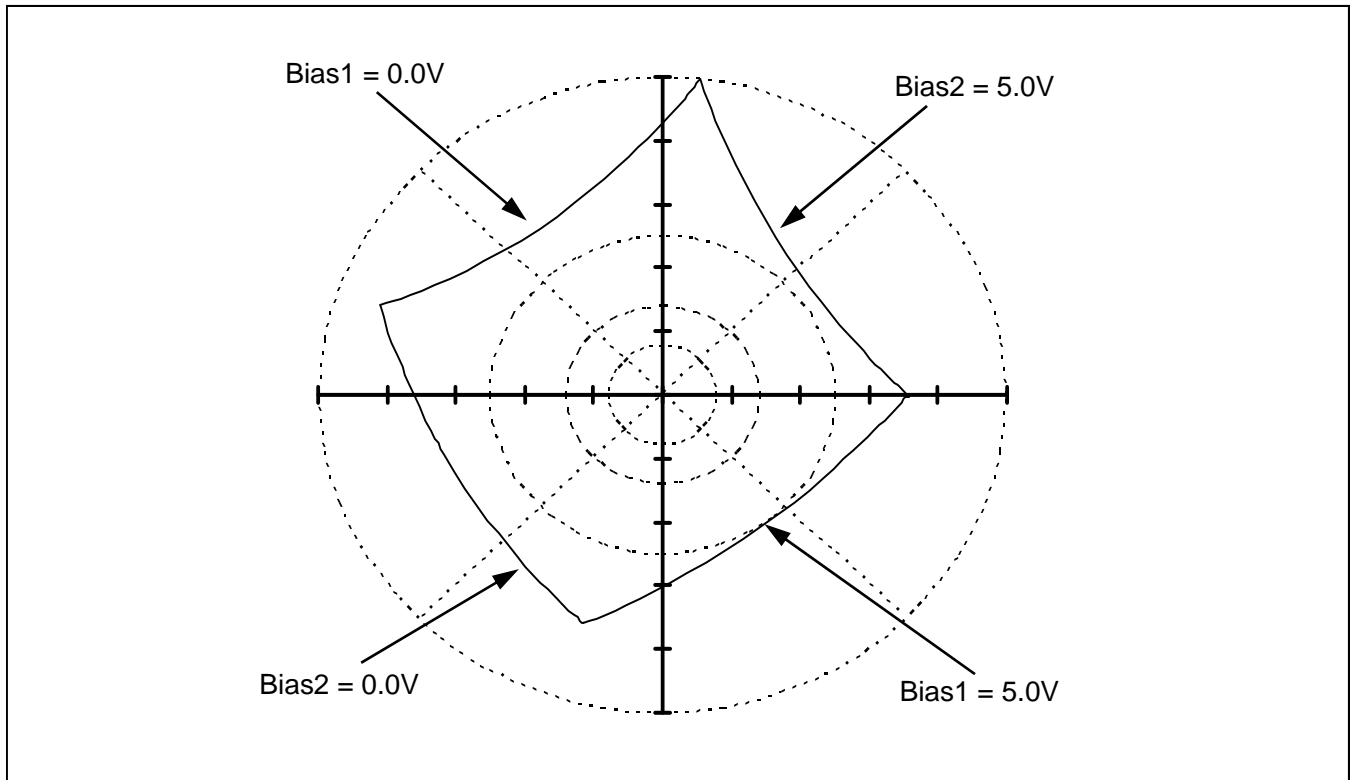
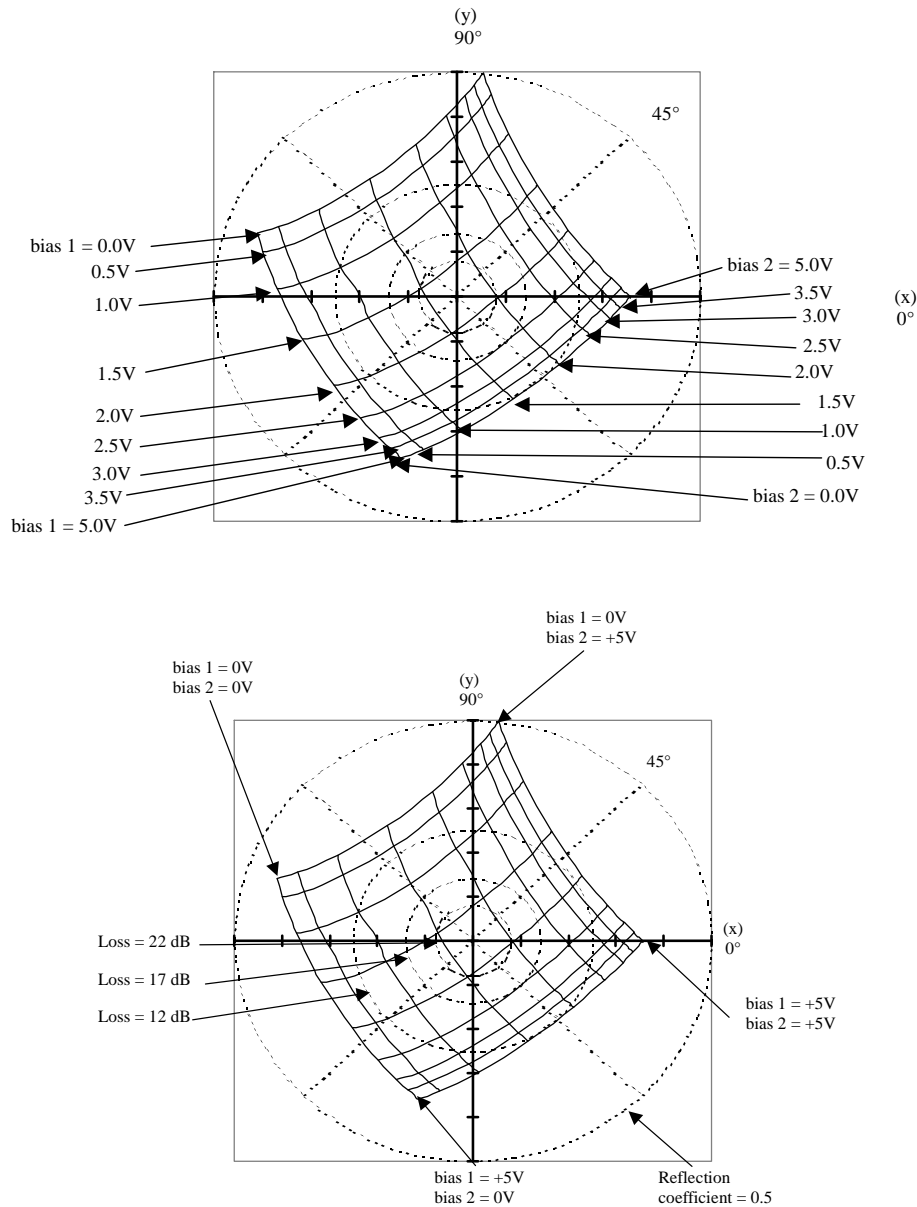

Figure 4. Transfer Function of Test to Determine Reference Loss

**PIN diode Vector Modulators -
Fundamentals and Drive Requirements**

Rev. V4



1. Tic marks on x,y axes refer to reflection coefficient in increments of 0.1V. Reflection coefficients vary from -0.5 to +0.5 on both the x and y axes.
2. Data is for vector modulators driven by linearizers per attached schematic.
3. Inputs to the linearizers vary from 0 to 5V.
4. The phase with the inputs to both linearizers set to +5V is arbitrarily called zero degrees.

Figure 5. Phase and Attenuation of MAMDCC0006, Vector Modulator Linearized with MADRCC0002 Linearizer

**PIN diode Vector Modulators -
Fundamentals and Drive Requirements**

Rev. V4

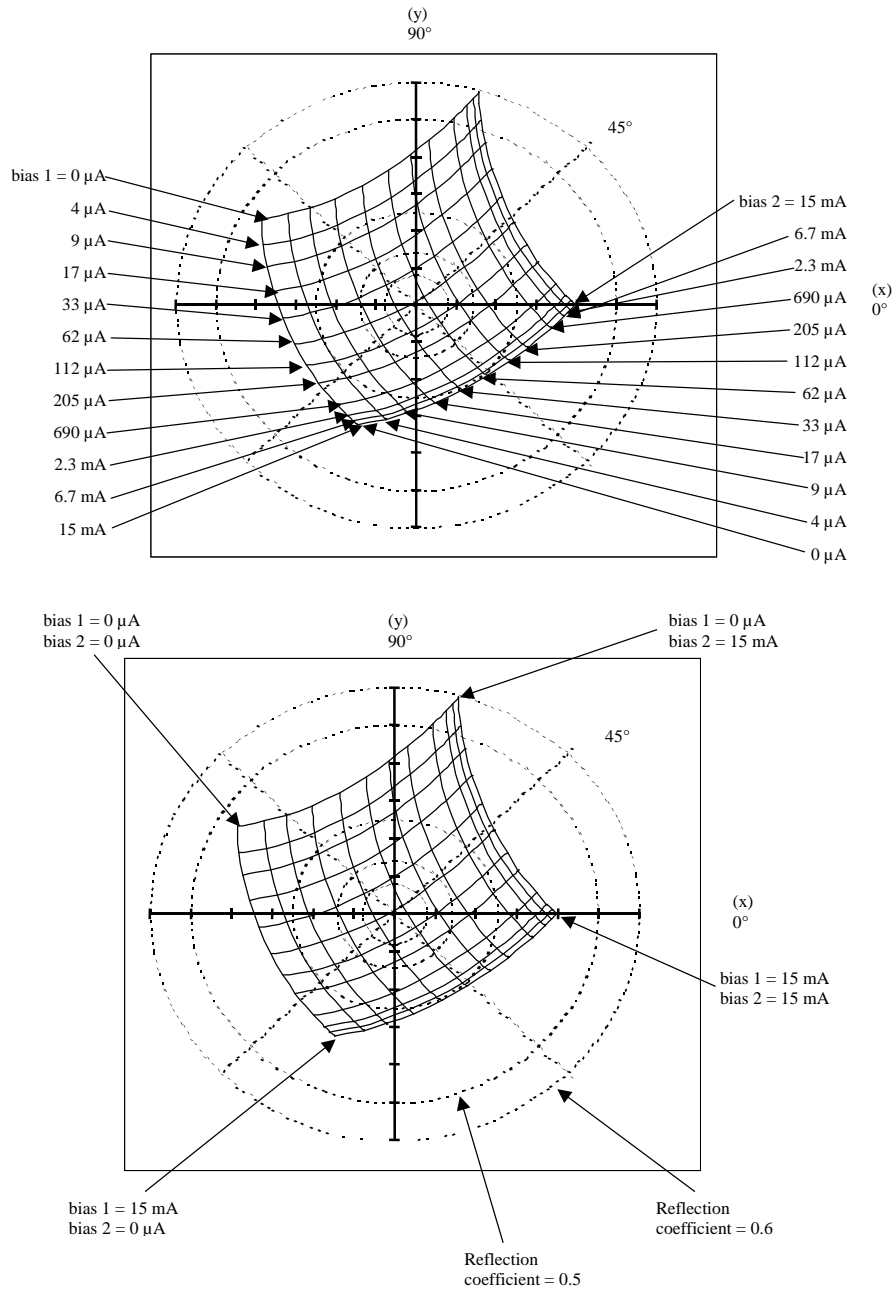

1. Tic marks on x,y axes refer to reflection coefficient in increments of 0.1. Reflection coefficients vary from -0.6 to $+0.6$ on both the x and y axes.
2. The phase with the inputs to both linearizers set to $+15V$ is arbitrarily called zero.

Figure 6. Phase and Attenuation of MAMDCC0006 vs. Bias Current

**PIN diode Vector Modulators -
Fundamentals and Drive Requirements**

Rev. V4

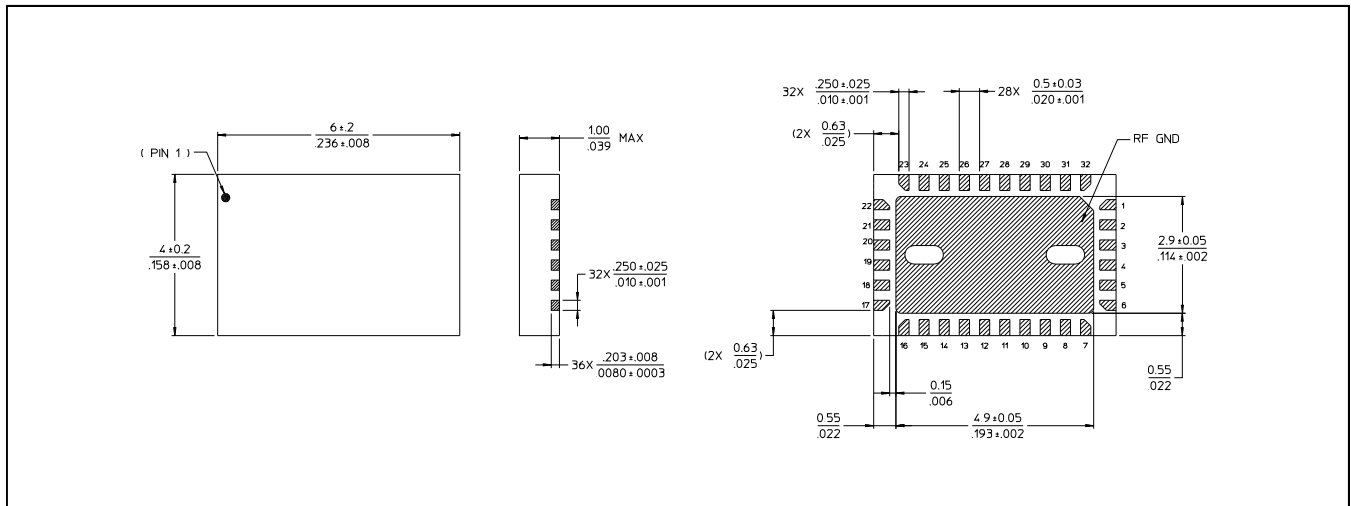

Figure 7. Outline Drawing

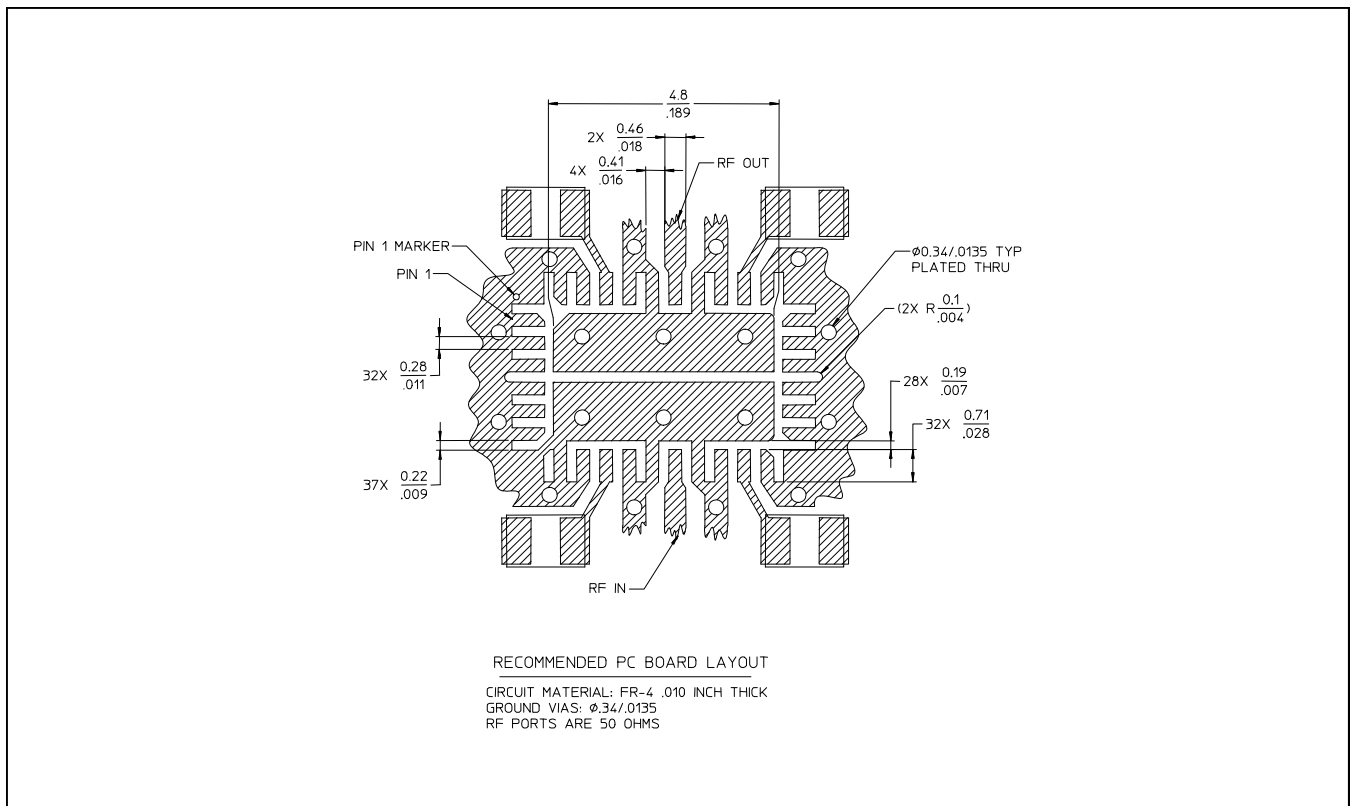

Figure 8. Recommended PC Board Mounting Pattern for Vector Modulators