

# ASL2417SHN

Enhanced two channel LED buck driver with limp-home

Rev. 4 — 16 September 2019

Product data sheet

## 1. Introduction

---

The ASL2417SHN is a two channel buck mode LED driver IC with a Limp-home mode. It delivers constant average DC current to LEDs independent of the input voltage. The ASL2417SHN supports up to two output channels. It means that with one driver IC, 1 or 2 LED strings can be driven independently of each other. It provides a cost effective design solution, specifically targeting automotive exterior and interior lighting applications.

## 2. General description

---

The ASL2417SHN has a hysteretic buck DC-to-DC topology. With input voltages from 10 V to 80 V, it allows maximum flexibility on output voltages for each channel, enabling applications with up to 20 LEDs. It also provides an output current of up to and above 1.5 A per channel.<sup>1</sup> Furthermore, the output channels can be connected together to provide an even higher current. It drives an external high-side N channel MOSFET from an internally regulated adjustable supply. The ASL2417SHN buck driver gives a flexible system design which can be used to drive two LED strings with the same architecture.

The ASL2417SHN provides an SPI interface for extensive control and diagnostic communication with an external microcontroller. Furthermore, the ASL2417SHN integrates a customer programmable Limp-home mode. It allows configurable operation in Limp-home mode in case SPI communication with the microcontroller has failed.

The ASL2417SHN offers an adjustable hysteresis for optimizing external components as well as minimizing LED current ripple.

In addition, the ASL2417SHN provides an output voltage of up to 70 V. It has a measurement capability that can be used to identify LED open or short circuit conditions. The microcontroller can read this voltage and use it to detect open or short circuit conditions. There are also additional diagnostic features such as current reached status.

Additional features include input under-voltage lockout and thermal shutdown when the junction temperature of the ASL2417SHN exceeds +175 °C.

It is housed in a very small HVQFN32 pin package with an exposed thermal pad and is designed to meet the stringent requirements of automotive applications. It is fully AEC Q100 grade 1 qualified. It operates over the ambient automotive temperature range of -40 °C to +125 °C.

---

1. The ASL2417 provides an accurate current over a 1 : 12.5 range. This range can be scaled up or down using external components. Depending on the operating conditions and component choices, output currents of min 30 mA and more than 3 A can be achieved.



### 3. Features and benefits

---

- The ASL2417SHN is an automotive grade product that is AEC-Q100 grade 1 qualified.
- Operating ambient temperature range of  $-40\text{ }^{\circ}\text{C}$  to  $+125\text{ }^{\circ}\text{C}$
- Wide operating input voltage range from  $+10\text{ V}$  to  $+80\text{ V}$
- Able to drive up to 20 LEDs, wide operating LED voltage range regulated from  $2.5\text{ V}$  to  $70\text{ V}$
- Output current of up to and above  $1.5\text{ A}$  with high LED current accuracy of  $\pm 5\%$  over the complete operating temperature range
- Output current programmable via SPI interface
- Read back programmed current via SPI
- Customer programmable Limp-home mode.
- Two output current ranges, programmable via SPI interface with  $5\%$  accuracy
- Hysteretic converter
- Fast gate drive for high efficiency
- Programmable internal gate driver voltage regulator
- Support logic level and standard level FETs
- Integrated bootstrap diode
- PWM inputs for individual dimming of each channel
- Low Electro Magnetic Emission (EME) and high Electro Magnetic Immunity (EMI)
- Input voltage monitoring and input under voltage protection
- Output voltage monitoring
- Control signal to enable the device
- Junction temperature monitoring via SPI
- Small package outline HVQFN32
- Low quiescent current  $< 5\text{ }\mu\text{A}$  at  $25\text{ }^{\circ}\text{C}$  when  $\text{EN} = 0$
- Short-circuit and open-circuit output protection

### 4. Applications

---

- Automotive LED lighting
  - ◆ Daytime running lights
  - ◆ Position or park light
  - ◆ Low beam
  - ◆ High beam
  - ◆ Turn indicator
  - ◆ Fog light
  - ◆ Cornering light
  - ◆ Advanced front lighting

## 5. Ordering information

Table 1. Ordering information

Type number	Package		Version
	Name	Description	
ASL2417SHN	HVQFN32	plastic thermal enhanced very thin quad flat package; no leads; 32 terminals; body 5 × 5 × 0.85 mm	SOT617-12

## 6. Block diagram

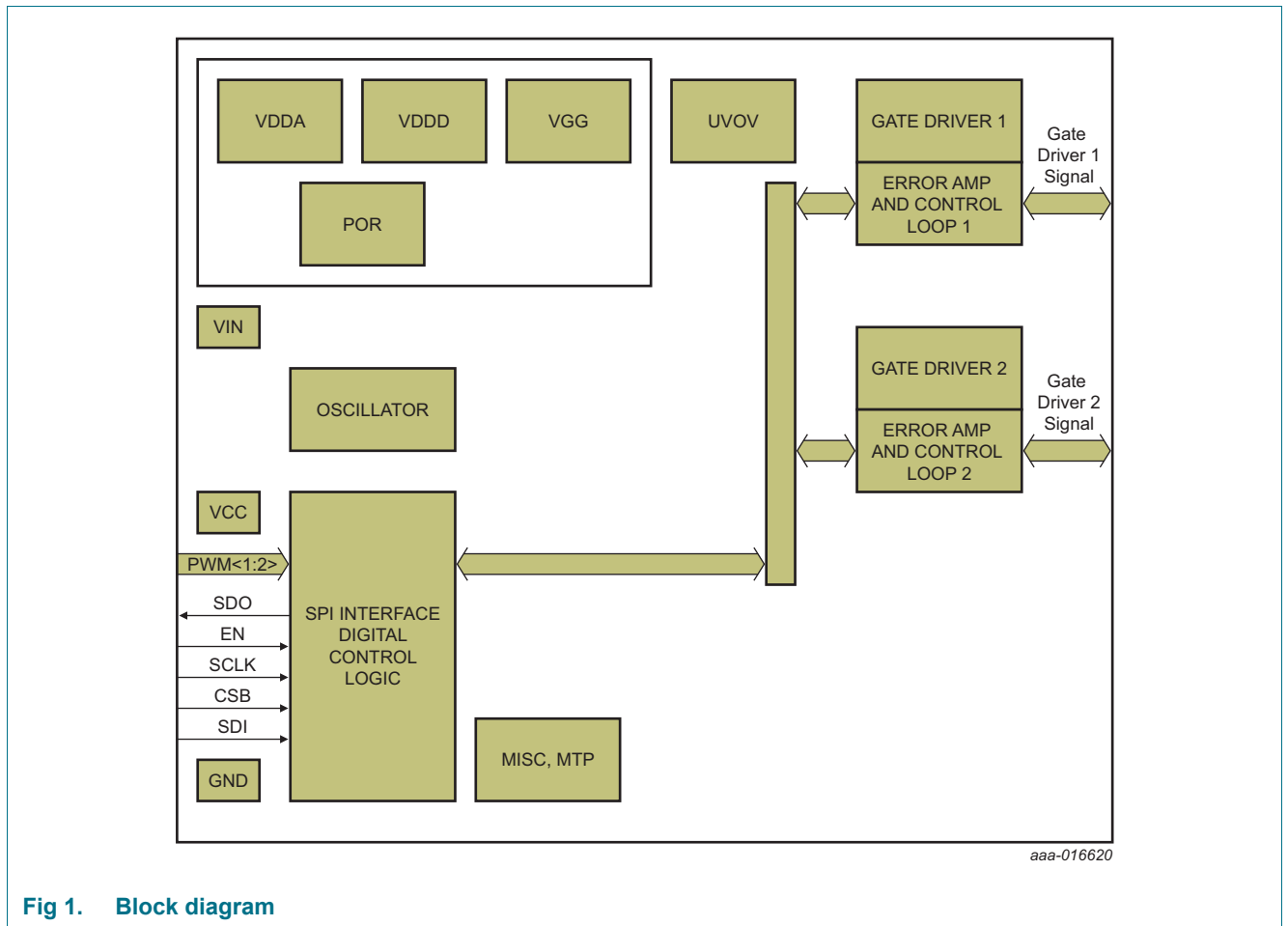
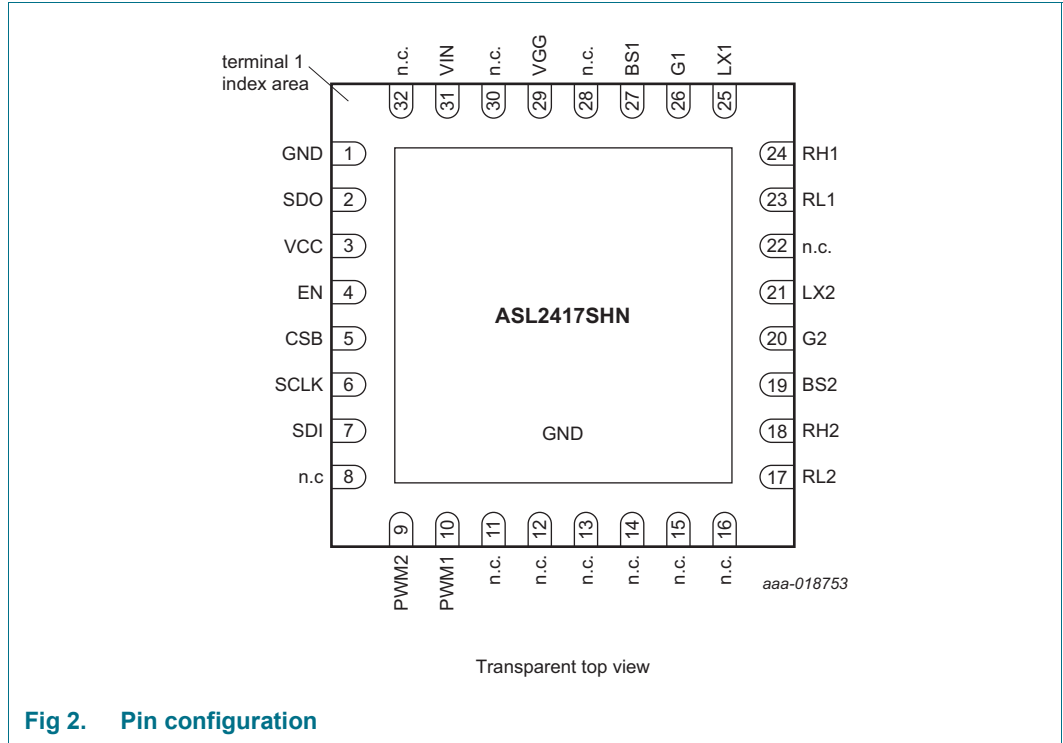

Fig 1. Block diagram

## 7. Pinning information

### 7.1 Pinning



### 7.2 Pin description

Table 2. Pin description<sup>[1]</sup>

Symbol	Pin	Description
GND	1	chip ground
SDO	2	SPI data out
VCC	3	external 5 V supply
EN	4	enable signal
CSB	5	SPI chip select
SCLK	6	SPI clock
SDI	7	SPI data input
n.c.	8	not connected
PWM2	9	external PWM signal channel 2
PWM1	10	external PWM signal channel 1
n.c.	11	not connected
n.c.	12	not connected
n.c.	13	not connected
n.c.	14	not connected
n.c.	15	not connected
n.c.	16	not connected

Table 2. Pin description<sup>[1]</sup>...continued

Symbol	Pin	Description
RL2	17	sense resistor low side channel 2
RH2	18	sense resistor high side channel 2
BS2	19	boot supply channel 2
G2	20	channel 2 gate driver
LX2	21	inductor connection to switching FET channel 2
n.c.	22	not connected
RL1	23	sense resistor low side channel 1
RH1	24	sense resistor high side channel 1
LX1	25	inductor connection to switching FET channel 1
G1	26	channel 1 gate driver
BS1	27	boot supply channel 1
n.c.	28	not connected
VGG	29	gate driver supply
n.c.	30	not connected
VIN	31	input voltage
n.c.	32	not connected

[1] Not connected (n.c.) pins are internally not connected and must be left floating to maintain high-voltage separation.

For enhanced thermal and electrical performance, the exposed center pad of the package should be soldered to board ground (and not to any other voltage level).

## 8. Functional description

### 8.1 Operating modes

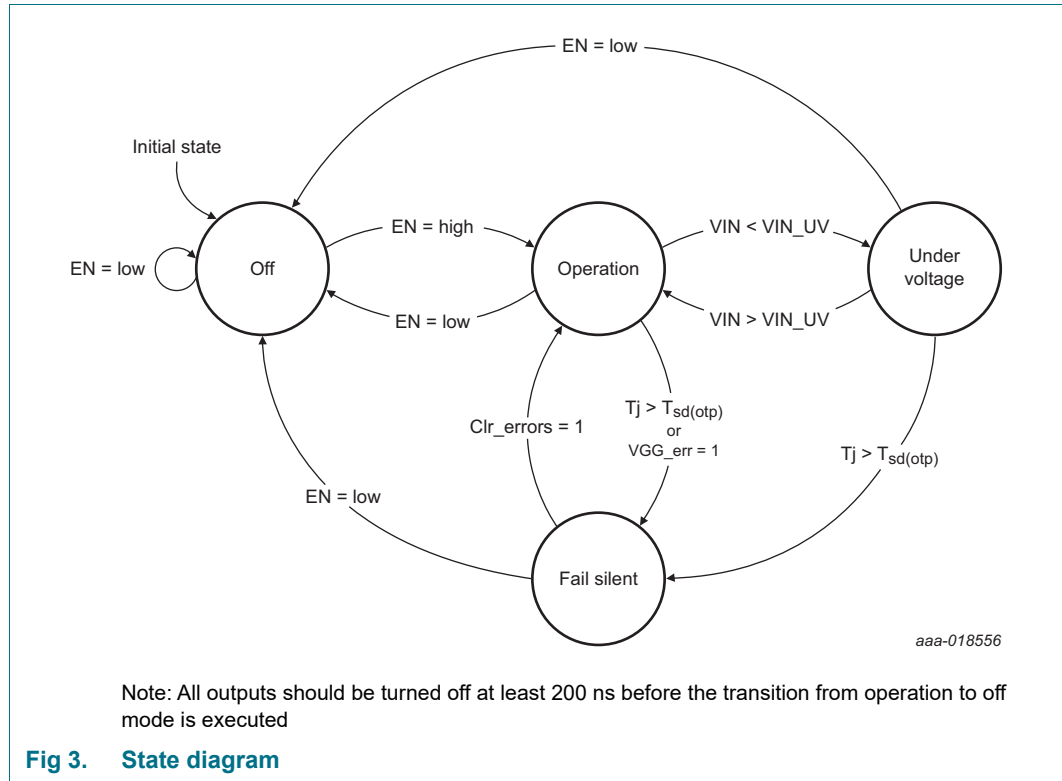

#### 8.1.1 Off mode

If the EN pin goes low, the ASL2417SHN switches to off mode.

In Off mode, the SPI interface and all outputs are turned off. Before off mode is entered, all channels should be turned off.

#### 8.1.2 Operation mode

The ASL2417SHN switches from Off mode to Operation mode when the input voltage is above the power-on detection threshold ( $V_{th(det)pon}$ ) and the EN pin is high. In operation mode, all outputs are available as configured via the SPI interface.

#### 8.1.3 Under voltage mode

The ASL2417SHN switches from operation mode to under voltage mode as soon as the input voltage drops below the programmed voltage. In under voltage mode, all outputs, including the gate voltage supply are off.

#### 8.1.4 Fail silent mode

The ASL2417SHN switches from Operation mode to Fail silent mode, when the junction temperature exceeds the over temperature shutdown threshold or a VGG error is detected.

In Fail silent mode, all outputs are turned off and only the SPI interface remains operational.

### 8.2 Buck converter

The ASL2417SHN is a buck converter IC delivering constant current to the LEDs. It is a hysteretic controller that regulates the inductor current. It switches off the external FET when the inductor current rises above the upper threshold current. It switches on when the current falls below the lower threshold. The width of the hysteresis window can be programmed via SPI to keep the switching frequency between bounds. The anode of the LED string is connected to the driver, while the cathode of the LED string is connected to ground. This arrangement helps to reduce the total number of connections to the LEDs.

### 8.3 Input voltage measurement

The ASL2417SHN measures the supply voltage of the device and makes this measurement available via the SPI interface.

Table 3. VIN voltage measurement register, address 0x38h[1]

Bit	Symbol	Description	Value	Function
7:0	V_VIN[7:0]	VIN voltage measurement	0x00h	voltage measurement not available
			...	VIN voltage = 0.3548 × V_VIN[7:0] – 0.56 V

[1] A write to the VIN voltage measurement register does not set the SPI error bit high.

### 8.4 Input under voltage detection

The ASL2417SHN offers a variable undervoltage detection threshold.

When the supply voltage is above the under voltage detection threshold, the bit VIN\_stat is high, when the supply voltage is below, the bit is low.

For effects of this bit on the functionality of the device, see [Section 8.12.1.1](#).

Table 4. Undervoltage threshold register, address 0x0Fh

Bit	Symbol	Description	Value	Function
7:0	V_VIN_UV[7:0]	undervoltage threshold	0x00h	undervoltage detection threshold = 0 V
			...	undervoltage detection threshold = 0.3548 × V_VIN_UV[7:0] – 0.56 V

### 8.5 Output current programmability

The ASL2417SHN provides the possibility to program the LED current and LED current hysteresis via the SPI interface.

#### 8.5.1 Output target current programming

The ASL2417SHN target output current, can be programmed via the LED current range registers and the LED current registers of channel 1 and 2. The sense voltage that is set via SPI, and the value of the external sense resistor, determine the actual level.

$$I_{LED} = \frac{V_{LEDcurrent}}{R_{sense}} \tag{1}$$

**Table 5. LED current range register, address 0x05h**

Bit	Symbol	Description	Value	Function
7:2		reserved	000000	reserved; keep clear for future use
1	I_CH2	LED current range bit channel 2	0	maximum sense voltage is approximately 300 mV
			1	maximum sense voltage is approximately 120 mV
0	I_CH1	LED current range bit channel 1	0	maximum sense voltage is approximately 300 mV
			1	maximum sense voltage is approximately 120 mV

**Table 6. LED current channel 1 register, address 0x02h**

Bit	Symbol	Description	Value	Function
7:0	I_LED_CH1[7:0]	LED current channel 1	0x00h; 0xF6h...0xFFh	not recommended
			...	When I_CH1 is 0: 1.179 mV × I_LED_CH1 + 0.74 mV
				When I_CH1 is 1: 0.47882 mV × I_LED_CH1 – 0.6 mV

**Table 7. LED current channel 2 register, address 0x03h**

Bit	Symbol	Description	Value	Function
7:0	I_LED_CH2[7:0]	LED current channel 2	0x00h; 0xF6h...0xFFh	not recommended
			...	When I_CH2 is 0: 1.179 mV × I_LED_CH2 + 0.74 mV
				When I_CH2 is 1: 0.47882 mV × I_LED_CH2 – 0.6 mV

The LED current is the result of the voltage drop across the  $R_{sense}$  resistor in mV.

Example:

To achieve an output current of e.g. 300 mA with 200 mΩ  $R_{sense}$  resistor on channel 1, two settings are possible:

1. Set bit I\_CH1 to 1 and the LED current channel 1 register to 0x7Eh
2. Set bit I\_CH1 to 0 and the LED current channel 1 register to 0x32h

For higher granularity and higher accuracy, use setting 1. When the LED current is dynamically adjusted to higher levels than offered when bit I\_CHx = 1, deviations are possible.

### 8.5.2 Hysteresis programming via SPI

ASL2417SHN provides an option to program the level of hysteresis via the SPI interface. The hysteresis setting is independent of the I\_CH1 and I\_CH2 bits in LED current range registers.

The hysteresis voltage that is set via SPI, and the value of the external sense resistor, determine the actual level.

$$I_{Hyst} = \frac{V_{Hyst}}{R_{sense}} \tag{2}$$

Depending on the hysteresis level, the values of the external components, the input and the output voltage, and the switching frequency varies.



The ASL2417SHN is specified for switching frequencies from 100 kHz to 2 MHz.

Note: For all hysteresis settings, the hysteresis, specified in mV, corresponds with the lowest average LED current in the static characteristics section.

**Table 8. Hysteresis channel 1 register, address 0x0Bh**

Bit	Symbol	Description	Value	Function
7:2		reserved	000000	reserved; keep clear for future use
1:0	HCH1[1:0]	hysteresis channel 1	00	setting 0
			01	setting 1
			10	setting 2
			11	setting 3

**Table 9. Hysteresis channel 2 register, address 0x0Ch**

Bit	Symbol	Description	Value	Function
7:2		reserved	000000	reserved; keep clear for future use
1:0	HCH2[1:0]	hysteresis channel 2	00	setting 0
			01	setting 1
			10	setting 2
			11	setting 3

By increasing the hysteresis level, the switching frequency is reduced, leading to less switching events and lower overall switching losses. However, the ripple of the LED current increases.

Calculation example:

A system has 40 V input voltage, an LED voltage of 15 V, a 200 mΩ R<sub>sense</sub>, and an inductor of 220 μH. It operates with a hysteresis of 20 mV at:

$$f = \frac{I}{T} = \frac{I}{T_{on} + T_{off}} = \frac{I}{I_{Hyst} \cdot \frac{L}{V_{IN} - V_{LED}} + I_{Hyst} \cdot \frac{L}{V_{LED}}} = \frac{V_{IN} \cdot V_{LED} - V_{LED}^2}{I_{Hyst} \cdot L \cdot V_{IN}} \approx 426 \text{ kHz} \quad (3)$$

Remarks:

The calculation above does not account for delays in the switching. Due to these delays, the measured switching frequency is lower than calculated here.

To avoid that the device is operating with undesired settings, pull the PWM pin high only when a channel is completely configured.

In case the PWM functionality is not needed, it is possible to connect the PWM pin directly to pin VCC. In this case, the PWM pin control bits can be used to enable or disable the channel. To avoid operation at an undesired frequency, the hysteresis for the channel should be set before the LED current register is set.

The hysteresis and LED current level can be adapted during operation of the device to enable smooth fade-in/fade-out scenarios down to very low output currents. It does it in combination with the PWM inputs.

### 8.5.3 Overcurrent protection

The ASL2417SHN offers an overcurrent protection feature in addition to the set trip points to protect the system. If the output voltage suddenly changes very fast, the upper and lower hysteric thresholds may deviate from actual target values. In case the deviation is too large the built-in overcurrent protection feature prevents the system from excessive current build-up.

In case such an event is detected, the gate driver will immediately be turned off for approximately 16 ms after which the system is restarted.

### 8.5.4 Output diagnostics

The diagnostic options for the outputs are:

- measurement of the output voltages during the LED on and off state - details can be found in [Section 8.6](#)
- indication that the target LED current is reached - details can be found in [Section 8.11](#)
- indication that a channel is operating with low voltage headroom - details can be found in [Section 8.12.3.1](#)

## 8.6 Output voltage measurement

The ASL2417SHN measures the output voltage of all channels every  $t_{meas\_per}$ . On a transition from the PWM pin of a channel, the measurement results are stored in the corresponding registers. The registers  $V\_LEDx\_on$ , contain the voltage information when the PWM input of the channel is high. The registers  $V\_LEDx\_off$ , contain the voltage information when the PWM input is low. It ensures that the registers contain the latest measured value of the individual channels with respect to the status of the PWM pin. If the PWM input of one channel stays constant for  $T_{LEDmeas\_stat}$ , the  $V\_LEDx\_on$  voltage register and the  $V\_LEDx\_off$  voltage register of this channel are updated.

**Table 10. LED on voltage channel 1 register, address 0x20h**

Bit	Symbol	Description	Value	Function
7:0	V_LED1_on[7:0]	LED on voltage channel 1	0x00h	LED on voltage = 0 V
			...	LED on voltage = $0.3548 \times V\_LED1\_on[7:0] - 0.56$ V

**Table 11. LED off voltage channel 1 register, address 0x21h**

Bit	Symbol	Description	Value	Function
7:0	V_LED1_off[7:0]	LED off voltage channel 1	0x00h	LED off voltage = 0 V
			...	LED off voltage = $0.3548 \times V\_LED1\_off[7:0] - 0.56$ V

**Table 12. LED on voltage channel 2 register, address 0x22h**

Bit	Symbol	Description	Value	Function
7:0	V_LED2_on[7:0]	LED on voltage channel 2	0x00h	LED on voltage = 0 V
			...	LED on voltage = $0.3548 \times V\_LED2\_on[7:0] - 0.56$ V

Table 13. LED off voltage channel 2 register, address 0x23h

Bit	Symbol	Description	Value	Function
7:0	V_LED2_off[7:0]	LED off voltage channel 2	0x00h	LED off voltage = 0 V
			...	LED on voltage = $0.3548 \times V\_LED2\_off[7:0] - 0.56$ V

## 8.7 External PWM input

The ASL2417SHN provides a dedicated PWM input for each of the two channels. It allows full control over the PWM frequency and duty cycle and allows phase shifting of the PWM cycles to balance the input current variations.

Pin PWM1 controls channel 1 and PWM2 controls channel 2. A high level at the pins represents that the corresponding channel is turned on and the configured current is delivered to the output.

As soon as the pin is pulled high, pin Gx of the corresponding channel starts toggling. It switches the MOSFET attached to the pin on and off and the system starts to deliver the configured output current.

As soon as the pin is pulled low, pin Gx of the corresponding channel is no longer turned on. The MOSFET stays off and no current is delivered to the output of the corresponding channel.

### 8.7.1 Control for PWM pins

The ASL2417SHN provides the option to disable the PWM input for each channel individually. In case the PWM input of one channel is disabled, this channel stays off, independent of any other conditions.

The bits to disable the PWM inputs are located in the function control register (refer to [Section 8.8](#) for details of the function control register).

### 8.7.2 Diagnostics for PWM functionality

The diagnostic options for the PWM functionality comprise the toggle information for the individual PWM pins. Details of the functionality can be found in [Section 8.8](#).

## 8.8 Function control register

To monitor the status of the SPI interface, use the function control register. It allows a reset of the fail silent mode and offers the control of the PWM inputs.

After enabling the device, the SPI\_status bit should be set. When a query returns that the bit is set, the SPI interface is operational and the device can be configured. Configuration of the device is not permitted before this bit is set.

When the device enters fail silent mode due to an error condition, bit Clr\_error can be set to bring the device back into operation mode. Once the error bits are cleared, the device clears the Clr\_error bit automatically. If the Clr\_error bit is set, when no error is present, the Clr\_error bit remains set, until an error occurs. This error is cleared automatically.

The functionality of bits PWMctrl1 and PWMctrl2, is described in [Section 8.7.1](#).

Table 14. Function control register, address 0x00h

Bit	Symbol	Description	Value	Function
7	SPI_status	SPI status bit	0	SPI is not available
			1	SPI is operating
6	Clr_error	clear error bits	0	no pending clear request
			1	request to clear error bits and reset fail silent mode pending
5:4		reserved	0	reserved; keep clear for future use
2	PWMctrl2	PWM control for pin PWM2	0	PWM2 is disabled, channel stays off
			1	PWM2 is enabled, LED current depends on PWM state and Register settings
1	PWMctrl1	PWM control for pin PWM1	0	PWM1 is disabled, channel stays off
			1	PWM1 is enabled, LED current depends on PWM state and Register settings
0		reserved	0	reserved; keep clear for future use

## 8.9 Gate voltage supply

The ASL2417SHN has an integrated linear regulator to generate the supply voltage of the gate drivers. The voltage generated by the linear regulator can be set via the VGG control register.

Table 15. VGG control register, address 0x01h

Bit	Symbol	Description	Value	Function
7:0	VGG[7:0]	VGG control	0x00h	not allowed
			...	not allowed
			0x5Dh	maximum output voltage = 10.20 V
			...	$16.1 \text{ V} - \text{VGG}[7:0] \times 63.4 \text{ mV}$
			0xA6h	minimum output voltage = 5.58 V
			...	not allowed
			0xFFh	not allowed

The actual value of VGG can deviate from the target setting due to the tolerances of the VGG regulation loop (see  $V_{o(\text{reg})\text{acc}}$  in [Table 39](#)).

When a setting between 0x00h and 0x5Dh is used, the resulting gate driver target voltage exceeds the limiting values of the IC. The limiting values of the VGG pin can also be violated with target settings of 0xA6h to 0x5Dh due to these tolerances. A violation of the limiting values with the actual VGG voltage must be avoided. To ensure that only allowed settings are used for the gate driver target voltage, an immediate read back of the programmed value is required after setting the registers.

If a setting between 0xFFh and 0xA6h is used, the device may shut down and signal a BS\_UV error. If the device operates, parameters of VGG are not guaranteed.

- VGG available. Details can be found in [Section 8.12](#)
- VGG overload protection active. Details can be found in [Section 8.12](#)

## 8.10 Junction temperature information

The ASL2417SHN provides a measurement of the IC junction temperature. The measurement information is available in the junction temperature register.

**Table 16.** Junction temperature register, address 0x26h

Bit	Symbol	Description	Value	Function
7:0	T_junction[7:0]	junction temperature	0xD8h	device junction temperature = $-40\text{ }^{\circ}\text{C}$
			...	device junction temperature = $(256 - T\_junction[7:0])\text{ }^{\circ}\text{C}$
			0xFFh	device junction temperature = $-1\text{ }^{\circ}\text{C}$
			0x00h	device junction temperature = $0\text{ }^{\circ}\text{C}$
			0x01h	device junction temperature = $1\text{ }^{\circ}\text{C}$
			...	device junction temperature = $T\_junction[7:0]^*\text{ }^{\circ}\text{C}$
			0xAFh	device junction temperature = $175\text{ }^{\circ}\text{C}$

The reading of the junction temperature register should be in the range as given in [Table 16](#). If not, the Tj\_err bit (Bit 5 in diagnostic register 1, address 0x37h) can be used to indicate whether the temperature is below  $175\text{ }^{\circ}\text{C}$  (Tj\_err = Low) or above  $175\text{ }^{\circ}\text{C}$  (Tj\_err = High).

## 8.11 Bootstrap recharge mechanism

The gate drivers and current delivered to the gate pins of the ASL2417SHN is supplied by the bootstrap capacitors. These capacitors are attached between the LXx and the BSx pins of the device. To allow a proper drive of the external FET, the voltage across this capacitor must remain near the target level of the gate drive voltage.

During device operation, if the external FET switches periodically at relatively high frequency, the bootstrap capacitor is charged when the Lx node is low. It is the case when the external FET is off and the converter coil is delivering current to the output.

When the external FET is not switching periodically, the bootstrap capacitor is recharged regularly every  $t_{\text{period}}$  when:

- the PWM pin is low for more than  $T_{\text{LEDmeas\_stat}}$
- the PWM is high and the CR0 bit is low

### 8.11.1 Bootstrap charge maintaining

There is an additional mechanism to maintain the bootstrap charge. This mechanism avoids a discharge of the bootstrap capacitors when the system is operated with long PWM off times and short PWM on times.

The ASL2417SHN compensates for the current consumption of the IC on the BS pins. As a result, the BS cap no longer discharges, but slowly settles around VBS-LX.

The compensating mechanism is enabled when the gate driver is enabled, the PWM is low, and no bootstrap undervoltage or low voltage headroom condition is detected.

## 8.12 Diagnostic information

Diagnostic registers contain useful information for diagnostic purposes. Details of each bit can be found in the following subchapters.

### 8.12.1 Diagnostic Register 1

The diagnostic register 1 contains information about the operational status of the ASL2417SHN.

**Table 17. Diagnostic register 1, address 0x37h**

Bit	Symbol	Description	Value	Function
7	VIN_stat	VIN status	0	VIN below under voltage detection threshold
			1	VIN above under voltage detection threshold
6	SPI_err	SPI error	0	last SPI command was executed correctly
			1	last SPI command was erroneous and has been discarded
5	Tj_err	device temperature is too high	0	device temperature below 175 °C
			1	device temperature above 175 °C
4	VGG_err	VGG error	0	VGG overload protection not active
			1	VGG overload protection has turned on and VGG is deactivated
3	VGG_ok	VGG regulation ok	0	VGG is not available
			1	VGG is available
2		reserved	0	reserved; keep clear for future use
1	I-CH2	target current reached on channel 2	0	target current was not reached during last PWM cycle
			1	target current was reached during last PWM cycle
0	I-CH1	target current reached on channel 1	0	target current was not reached during last PWM cycle
			1	target current was reached during last PWM cycle

#### 8.12.1.1 Bit VIN\_stat

The bit VIN\_stat indicates the VIN voltage status of the device. This bit is set once the VIN voltage is higher than programmed under voltage threshold value. When VIN is less than the programmed under voltage threshold value, the bit is cleared (see [Section 8.4](#) for details about the input under voltage detection functionality).

When the bit is high, the gate pins start switching. The device starts to deliver the output current as requested via the PWM inputs of the corresponding channels. The bits VGG\_ok and VGG\_err indicate the functional status of VGG.

When the bit is low, the VGG regulator and gate drivers are turned off. The gate pins stop switching, resulting in a turn-off of the output currents. The bit VGG\_ok is reset, the bit VGG\_err is not changed and the VLED measurement registers are no longer updated.

**Table 18. Effect of VIN\_stat on device functionality**

Status of VIN	VIN_stat	VGG_ok	VGG_err	Output current	VLED measurement
below under voltage detection threshold	0	reset	cannot be set	disabled	no update
above under voltage detection threshold	1	no influence	no influence	enabled	updated when VGG_ok is 1

### 8.12.1.2 Bit SPI\_err

The bit SPI\_err indicates if some error has occurred during the last SPI transfer. When this bit is set after a write access to the device, the device discards the command. When the bit is set after a read command, the microcontroller should discard the information delivered by the device. The SPI\_err bit is set in the following cases:

- SPI write is attempted to a read-only location or reserved location
- SPI read is attempted from a reserved location
- SPI command does not consist of a multiple of 16 clock counts

The SPI\_err bit is cleared on a write to the diagnostic register 1.

In case a SPI\_error has been detected, the device will return the diagnostic register 1 (default read) and diagnostic register 2 for the next SPI access.

### 8.12.1.3 Bit Tj\_err

When the junction temperature rises above the maximum allowable temperature ( $T_{sd(otp)}$ ), bit Tj\_err is set high. It turns off the gate driver and the gate driver voltage regulator, and clears bit VGG\_ok. If VGG\_ok was already set high, bit VGG\_err is set. The output current is no longer delivered. Only the SPI remains operational.

Bit Tj\_err must only be cleared with the Clr\_errors command when the junction temperature is below the maximum allowable temperature threshold again. Bit VGG\_err, that is set together with bit Tj\_err, is cleared together with bit Tj\_err.

### 8.12.1.4 Bit VGG\_err

The bit VGG\_err is set when VGG cannot be regulated to its target value. During start-up, the device waits for 12 ms until the bit gets set, during normal operation the device waits only 1 ms. Once the bit is set, it turns off the gate driver, VGG voltage regulator and clears the bit VGG\_ok. Consequently, output current can no longer be delivered. Only the SPI remains operational.

In case the VGG\_err bit is set, the LED voltage measurement is no longer updated.

To reset the bit, the bit Clr\_errors in the function control register can be set. Alternatively, the device must be set to off mode, e.g. by EN going low, or a power-on reset.

### 8.12.1.5 Bit VGG\_ok

The bit VGG\_ok is set, as soon as the VGG output is regulated to the target value. The bit is cleared on an under voltage condition at VIN, or an error on VGG.

### 8.12.1.6 Bits I-Ch1 and I-CH2

The bits I-CH1 and I-CH2 indicate whether the targeted output current was reached or not in the last PWM cycle. Reasons for not reaching the target current can be e.g. an open LED string or a too low input voltage.

The bits are updated for a:

- falling edge of the PWM
- write of the CR copy pulse bit

The bits are cleared for a:

- VIN undervoltage event
- low voltage headroom event on the representative channel

### 8.12.1.7 CR copy pulse

The bits CCH1 and CCH2 can be used to force an update of the LED current reached information. Setting a bit high, initiates an update of the I-CHx bit in the diagnostic register 1 and clears the CR0\_CHx bit. The device automatically clears the bit that was set high, after the update.

**Table 19. CR copy pulse register, address 0x06h**

Bit	Symbol	Description	Value	Function
7:2		reserved	000000	reserved; keep clear for future use
1	CCH2	update request for bit I-CH2	0	no pending update request
			1	update request for bit I-CH2
0	CCH1	update request for bit I-CH1	0	no pending update request
			1	update request for bit I-CH1

### 8.12.2 Diagnostic register 2

The diagnostic register 2 contains the PWM toggle information of the ASL2417SHN.

**Table 20. Diagnostic register 2, address 0x36h**

Bit	Symbol	Description	Value	Function
7		reserved	0	reserved; keep clear for future use
6		reserved	1	reserved; keep clear for future use
5		reserved	000	reserved; keep clear for future use
4	NVM_fail	NVM_access failed	0	no NVM access failed
			1	NVM access failed
3	NVM_ok	NVM_access completed	0	no NVM access completed
			1	NVM access completed
2		reserved	000	reserved; keep clear for future use
1	PWM2	toggle information for pin PWM2	0	PWM2 has not toggled since last time the register was read
			1	PWM2 has toggled since last time the register was read
0	PWM1	toggle information for pin PWM1	0	PWM1 has not toggled since last time the register was read
			1	PWM1 has toggled since last time the register was read

#### 8.12.2.1 Bit NVM\_fail

When the ASL2417SHN rejects the write to the particular NVM address location, bit NVM\_fail is set. The bit is reset on a write to diagnostic register 2.

#### 8.12.2.2 Bit NVM\_ok

When the ASL2417SHN accepts the write/read to/from the particular NVM address location and the write/read process is completed, the NVM\_ok bit is set. The bit is reset on a write to diagnostic register 2.



### 8.12.2.3 PWM toggle information (bits PWM1 and PWM2)

To allow the detection of errors in the control of the PWM pins, the ASL2417SHN allows some diagnostics of the PWM inputs via diagnostic register 2. This register contains the toggle information of the PWM inputs.

The bits are set when a change in the level of the pin is detected. The bits are reset on a write to diagnostic register 2.

### 8.12.3 Diagnostic register 3

Diagnostic register 3 contains the low voltage headroom warning information and the output current state bits.

#### 8.12.3.1 Low voltage headroom warning

When the ASL2417SHN operates with low voltage headroom, it could lead to very high duty cycles. Subsequent long on-times for the external FET, could result in low switching frequencies. To avoid long on-times of the external FET, the supply voltage and output voltages are continuously monitored while the channel is on and VIN\_stat is high. Once the output voltage is measured to be above  $V_{in}$  minus  $V_{Head\_low}$ , the gate pin is pulled low. It results in the FET being turned off. At the same moment in time, the low voltage headroom bit (LV\_CHx in diagnostic register 3) for the corresponding channel is set.

If the voltage difference is again above  $V_{Head\_low}$ , the device starts to operate again.

Bits LV\_CH1 and LV\_CH2 remain set until a write to the diagnostic register 3 is performed. If the bits are cleared while the channels are turned off or VIN\_stat is low, the bits might be set again if the last sampled voltage indicates a low voltage headroom condition.

#### 8.12.3.2 Output current state

Diagnostic register 3 also contains bits CR0\_CH1 and CR0\_CH3. The bits indicate the target current reached information of the individual channels for the current PWM cycle.

The bits are set as soon as the target current of the channel is reached.

The bits are cleared under the following conditions:

- a falling edge on the PWM pin
- a VIN under voltage event
- a CR0 copy pulse request via SPI
- the gate is driven high for more than 1 ms while PWM is high

### 8.12.3.3 Register content

Table 21. Diagnostic register 3, address 0x35h

Bit	Symbol	Description	Value	Function
7:5		reserved	00	reserved; keep clear for future use
4	CR0_CH2	current reached CH2	0	output current is not reached
			1	output current is reached
3	CR0_CH1	current reached CH1	0	output current is not reached
			1	output current is reached
2		reserved	00	reserved; keep clear for future use
1	LV_CH2	low voltage headroom in CH2	0	no low headroom event occurred
			1	at least one low headroom event occurred
0	LV_CH1	low voltage headroom in CH1	0	no low headroom event occurred
			1	at least one low headroom event occurred

### 8.12.4 Diagnostic register 4

Diagnostic register 4 contains the BS undervoltage detection bits.

#### 8.12.4.1 Bootstrap undervoltage detection

The integrated bootstrap undervoltage detection monitors the voltage between the BS and the LX pins during the off time of the LX pin. If the voltage drops below VBS\_UV, the ASL2417SHN prevents the gate from being turned-on and prevent the MOSFET being driven at a low voltage.

When this condition is detected on a channel, the channel is turned off and the appropriate error bit is set. A write command to the device clears the error bit and any bits to be cleared are set high. Once the error is cleared, the channel is enabled again.

Table 22. BS\_UV register - read access, address 0x34h

Bit	Symbol	Description	Value	Function
7:2		reserved	00000	reserved; keep clear for future use
1	BS_UV2	low BS warning CH2	0	no low BS event occurred
			1	at least one low BS event occurred
0	BS_UV1	low BS warning CH1	0	no low BS event occurred
			1	at least one low BS event occurred

Table 23. BS\_UV register - write access, address 0x34h

Bit	Symbol	Description	Value	Function
7:2		reserved	00000	reserved; keep clear for future use
1	BS_UV2	low BS warning CH2	0	no action
			1	clear low BS warning for channel 2
0	BS_UV1	low BS warning CH1	0	no action
			1	clear low BS warning for channel 1

### 8.13 Limp-home mode

The ASL2417SHN offers a Limp-home mode and the detection of a loss of SPI communication, activates it. In Limp-home mode, the outputs are operating according to a pre-defined condition stored in a non-volatile memory (NVM). [Figure 4](#) shows the operation state diagram of the Limp-home mode and [Table 24](#) gives an overview of the behavior of the ASL2417SHN in the states.

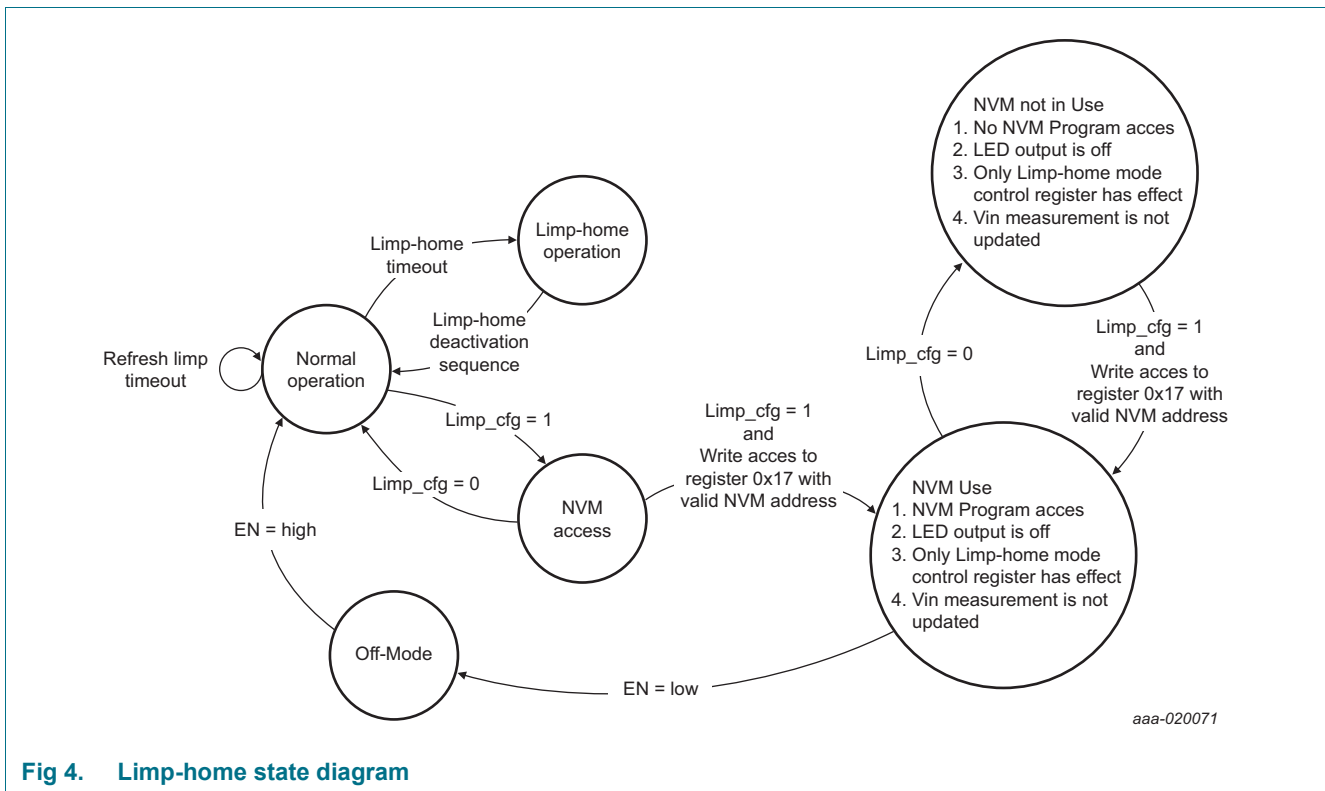

Fig 4. Limp-home state diagram

Table 24. Limp-home state overview

Mode	Outputs	Register access	MTP access	Remark
Normal operation	as defined via registers and PWM input	full access to SPI registers	no	normal operation consists of operation, undervoltage and fail silent mode (see <a href="#">Figure 3</a> )
Limp-home operation	as defined per limp-home configuration	write to limp home control register allowed; other control registers are set to the NVM values.	no	limp-home operation offers same states as normal operation mode
NVM access	as defined via registers and PWM input	full access to SPI registers	no	once NVM access mode is entered, the limp-home refresh timer is stopped.
NVM Use	outputs disabled	SPI registers are programmable but values have no effect	read/write	to restart it, a power-on reset via EN is required
NVM not in use	outputs disabled	SPI registers are programmable but values have no effect	no	the use of this state is not recommended

The settings with which the device operates in limp-home settings can be configured in NVM Use mode. In NVM Use mode, the outputs are disabled. After configuration, the limp-home settings will be permanently stored. Once the ASL2417SHN detects a loss of the communication, the device populates these settings into the registers and operates according to them.

In case the system recovers from the error, Limp-home mode can be left via the exit Limp-home mode sequence. With the completion of the exit sequence, the device already operates according to the applied levels on the PWM pin inputs. The configuration registers are open for write configuration again.

Limp-home and normal mode operation offer the same operational behavior. It includes the undervoltage behavior as well as the fails silent behavior. When the fail silent mode is entered, the system cannot execute an automatic recovery in either the normal operation mode or the Limp-home mode.

### 8.13.1 Limp-home mode activation

Limp-home mode is automatically entered if no write to the Limp-home mode exit bits (register 0x33h, bits 6:4) with data 111, is executed for the time-out time. The time-out time is defined in the Limp-home mode control register.

### 8.13.2 Limp-home mode operation

Once the system has entered Limp-home mode, the ASL2417SHN switches to the configuration as defined in the NVM memory for Limp-home mode. The ASL2417SHN modifies the control registers accordingly. During Limp-home mode operation, the SPI interface remains functional, but only the Limp-home mode control register can be written. The other registers offer only read access.

### 8.13.3 Limp-home mode deactivation

To deactivate Limp-home mode, a dedicated Limp-home mode deactivation sequence must be written to the Limp-home mode control register.

**Table 25. Limp-home mode deactivation sequence**

Deactivation step	Data to Limp_exit [2:0]
step 1	001
step 2	010
step 3	100

Once the deactivation sequence is completed, the ASL2417SHN immediately starts to react on the PWM inputs. The registers remain as set for the Limp-home mode. As the system is now back to operation mode, all registers are accessible as defined for operation mode again.

### 8.13.4 Limp-home mode control register

The Limp-home mode control register allows control of the Limp-home mode.

**Table 26.** Limp-home mode control register, address 0x33h

Bit	Symbol	Description	Value	Function
7	Limp_status	Limp-home mode status	0	device is not in limp-home mode
			1	device is in limp-home mode
6:4	Limp_exit	Limp-home mode exit bits <sup>[1]</sup>	...	bits for limp home mode deactivation sequence and SPI time-out trigger
3:1	Limp_timeout	time-out setting for activation of limp-home mode <sup>[2]</sup>	000	Limp-home time-out setting 1
			001	Limp-home time-out setting 2
			010	Limp-home time-out setting 3
			011	Limp-home time-out setting 4
			100	Limp-home time-out setting 5
			101	Limp-home time-out setting 6
			110	Limp-home time-out setting 7
			111	Limp-home time-out setting 8
0	Limp_cfg	Limp-home mode configuration mode	0	not in limp-home mode configuration mode
			1	system in limp-home mode configuration mode

[1] When refreshing the time-out timer, the limp home mode time-out setting must be written as well.

[2] When changing the limp home mode time-out setting, the limp\_exit bits should be set to 111 to refresh the time-out timer.

### 8.13.5 NVM Write Sequence

The limp home configuration of the ASL2417SHN can be stored in a non-volatile-memory (NVM). In NVM Use mode, data can be written to the NVM using the following sequence:

1. Clear the previous NVM bits by writing the Diagnostic Summary Register 2 (address 0x36h) with any data.
2. Write required NVM data [7:0] into SPI register 0x18h.
3. Write required NVM data [15:8] into SPI register 0x19h.
4. Finally, to start the programming process, write the NVM address into SPI register 0x17h with bit NVM\_write set high.
  - a. If access to the NVM is allowed at these address locations, the ASL2417SHN programs the NVM memory. After programming, the bit NVM\_ok is set.
  - b. If access to the NVM is not allowed at these address locations, the ASL2417SHN does not modify the NVM memory and set bit NVM\_fail high.
5. The next operation can be initiated after the NVM write is completed.

### 8.13.6 NVM read sequence

The limp-home configuration of the ASL2417SHN can be stored in a non-volatile-memory (NVM). To read data to the NVM, use the following sequence:

1. Clear the previous NVM bits by writing the Diagnostic Summary Register 2 (address 0x36h) with any data.
2. To start the read process, write the NVM address into SPI register 0x17h with bit NVM\_read set high.

3. Obtain the read completion status by reading the Diagnostic Summary Register 2 (0x36h).
4. NVM data [7:0] is now available via SPI register 0x28h.
5. NVM data [15:8] is now available via SPI register 0x29h.
6. The next operation can be initiated after the NVM read is completed.

### 8.13.7 NVM register map

The ASL2417SHN allows limp home values for all control registers that can be configured during normal operation to be set. [Table 27](#) links the NVM addresses to the register addresses.

**Table 27. Mapping of NVM registers to control registers**

NVM address linked to SPI register 0x17h [4:0]	NVM data linked to SPI register 0x19h [15:8] <sup>[1]</sup>	NVM data linked to SPI register 0x18h [7:0] <sup>[1]</sup>
0x10h	LED current channel 2 (SPI register address 0x03h) default: 0x00h	LED current channel 1 (SPI Register Address 0x02h) default: 0x00h
0x11h	VGG control (SPI register address 0x01h) default: 0x96h	-
0x12h	NVM_Hyst, default: 0x00h (see <a href="#">Table 28</a> )	Under voltage threshold (SPI Register Address 0x0Fh) default: 0x00h
0x13h	-	NVM_PWM_ctrl, default: 0x2Ah (see <a href="#">Table 28</a> )

[1] Register 0x18h and 0x19h are used for write to NVM and register 0x28h and 0x29h are used for read from NVM.

The content NVM Data fields that contain more than just one register are shown in [Table 28](#).

**Table 28. Overview of multi-content NVM data fields**

NVM Address	Name	7	6	5	4	3	2	1	0
0x12h; Data[15:8]	NVM_Hyst	LED current range_CH2 (SPI register address 0x05h bit 1)	LED current range_CH1 (SPI register address 0x05h bit 0)	-		[2:3] Hysteresis channel 2 (SPI register address 0x0Ch)	[1:0] Hysteresis channel 1 (SPI register address 0x0Bh)		
0x13h; Data[7:0]	NVM_PWM_ctrl	-	-	NVM_PWM2[1:0] (see <a href="#">Table 29</a> )		NVM_PWM1[1:0] (see <a href="#">Table 29</a> )		-	

In Limp-home mode, the ASL2417SHN offers the option to override the PWM input to turn channels individually ON, OFF, or allow them to react to pin PWM. [Table 29](#) shows the possible configurations of the channels during Limp-home mode.

Table 29. NVM\_PWMx bits

NVM_PWMx[1:0]	Channel reaction
00	Channel x is turned off in limp home mode
01	Channel x reacts to PWMx in limp home mode
10	Channel x is turned on in limp home mode
11	Channel x reacts to PWMx in limp home mode

### 8.14 SPI

The ASL2417SHN uses an SPI interface to communicate with an external microcontroller. The SPI interface can be used for setting the LEDs current, reading and writing the control register.

#### 8.14.1 Introduction

The Serial Peripheral Interface (SPI) provides the communication link with the microcontroller, supporting multi-slave operations. The SPI is configured for full duplex data transfer, so status information is returned when new control data is shifted in. The interface also offers a read-only access option, allowing the application to read back the registers without changing the register content.

The SPI uses four interface signals for synchronization and data transfer:

- CSB - SPI chip select; active LOW
- SCLK - SPI clock - default level is LOW due to low-power concept
- SDI - SPI data input
- SDO - SPI data output - floating when pin CSB is HIGH

Bit sampling is performed on the falling clock edge and data is shifted on the rising clock edge as illustrated in [Figure 5](#).

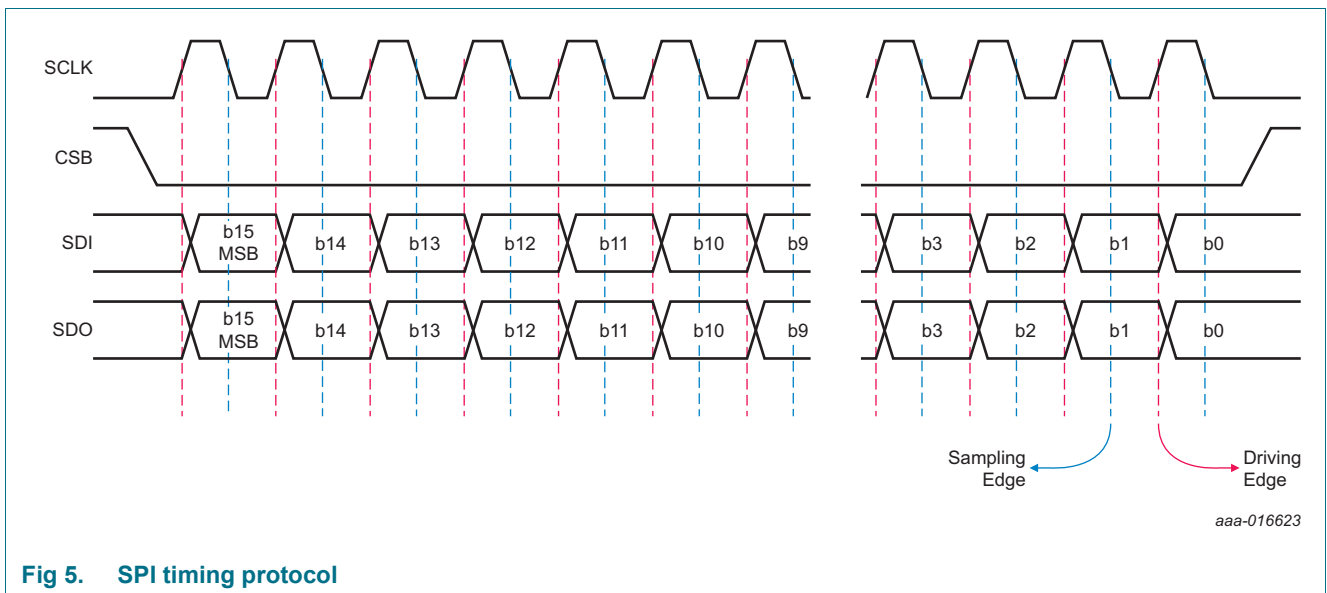

The data bits of the ASL2417SHN are arranged in registers of 1 byte length. Each register is assigned to a 7-bit address. For writing into a register, 2 bytes must be sent to the LED driver. The first byte is an identifier byte that consists of the 7-bit address and one read-only bit. For writing, the read-only bit must be set to “0”. The second byte is the data that shall be written into the register. So an SPI access consists of at least 16 bits.

Figure 6 together with Table 30 and Table 31 demonstrate the SPI frame format.

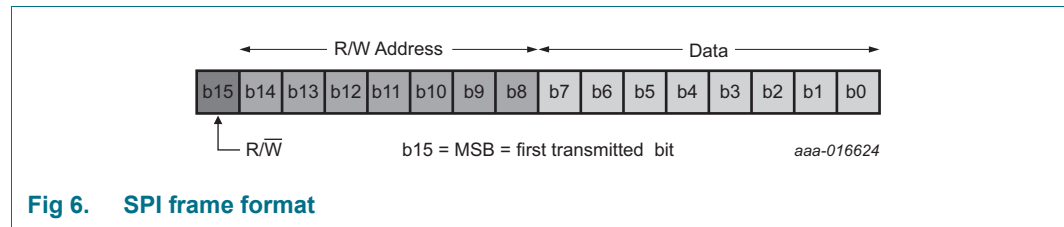

Fig 6. SPI frame format

Table 30. SPI frame format for a transition to the device

Bit	Symbol	Description	Value	Function
15	b15	R/W bits	0	write access
			1	read access
14:8	b14:8	address bits	...	selected address
7:0	b7:0	data bits	...	transmitted data

Table 31. SPI frame format for a transition from the device

Bit	Symbol	Description	Value	Function
15:8	b15:8	diagnostic register 1	...	content of diagnostic register 1
7:0	b7:0	data bits	...	when previous command was a valid read command, content of the register that is supposed to be read
			...	When previous command was a valid write command, new content of the register that was supposed to be written

Note: The first SPI command after a leaving of off mode returns 0x00h.

The Master initiates the command sequence. The sequence begins with CSB pin pulled low and lasts until it is asserted high.

The ASL2417SHN also tolerates SPI accesses with a multiple of 16 bits. It allows a daisy chain configuration of the SPI.



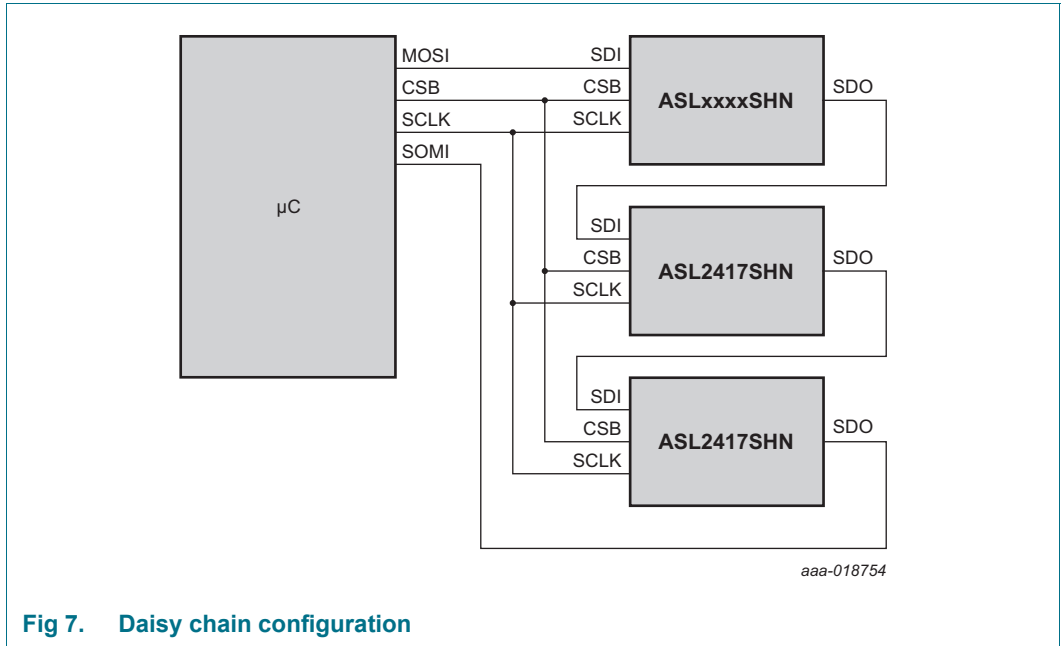

Fig 7. Daisy chain configuration

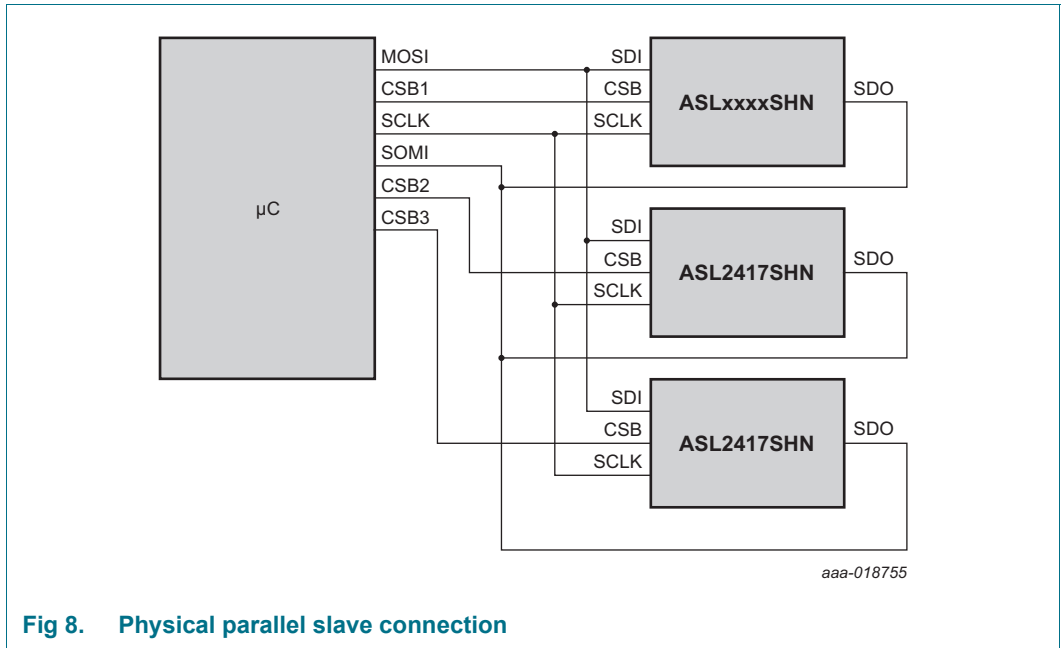

Fig 8. Physical parallel slave connection

During the SPI data transfer, the identifier byte and the actual content of the addressed registers is returned via the SDO pin. The same happens for pure read accesses. Here the read-only bit must be set to 1. The content of the data bytes that are transmitted to the ASL2417SHN is ignored.

The ASL2417SHN monitors the number of data bits that are transmitted. If the number is not 16, or a multiple of 16, then a write access is ignored and the SPI error indication bit is set.

8.14.2 Typical use case illustration (write/read)

Consider a daisy chain scheme with one master connected to 4 slaves in Daisy chain fashion. The following commands are performed during one sequence (first sequence).

- write data 0xFF to register 0x1A slave 1
- read from register 0x02 of slave 2
- write data 0xAF to register 0x2F of slave 3
- read from register 0x44 of slave 4

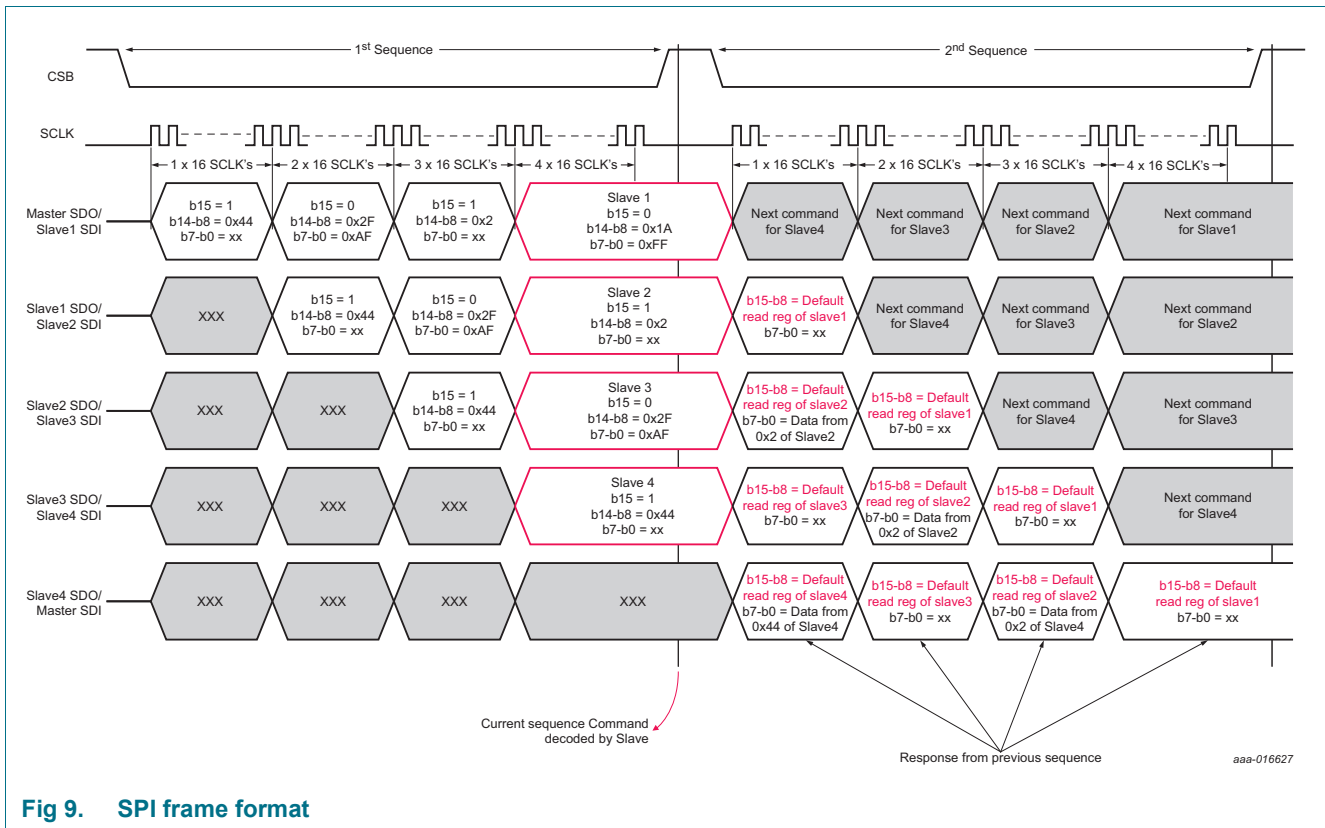

Fig 9. SPI frame format

8.14.3 Diagnostics for the SPI interface

The diagnostic options for the SPI interface are Error during last SPI transfer. For details, refer to [Section 8.11](#).

8.14.4 Register map

The addressable register space amounts to 128 registers from 0x00 to 0x7F. They are separated in two groups as shown in [Table 32](#). The register mapping is shown in [Table 33](#) and [Table 34](#). The functional description of each bit can be found in the dedicated chapter.

Table 32. Grouping of the register space

Address range	Description	Content
0x00 ... 0x1F	control registers	thresholds, LED currents
0x20 ... 0x7F	diagnostic registers	LED voltages, PWM toggle information

### 8.14.4.1 Control registers

[Table 33](#) provides an overview of the control registers and their reset state.

**Table 33. Control register group overview**

Address	Name	Reset value	7	6	5	4	3	2	1	0
0x00h	function control	0x0Eh	SPI_status	Clr_errors	-	-	-	PWMctrl 2	PWMctrl 1	-
0x01h	VGG control	0x96h	VGG[7:0]							
0x02h	LED current channel 1	0x00h	I_LED_CH1[7:0]							
0x03h	LED current channel 2	0x00h	I_LED_CH2[7:0]							
0x05h	LED current range	0x07h	-	-	-	-	-	-	I_CH2	I_CH1
0x06h	CR copy pulse	0x00h	-	-	-	-	-	-	CCH2	CCH1
0x0Bh	hysteresis channel 1	0x03h	-	-	-	-	-	-	HCH1[1:0]	
0x0Ch	hysteresis channel 2	0x03h	-	-	-	-	-	-	HCH2[1:0]	
0x0Fh	undervoltage threshold	0xFFh	V_VIN_UV[7:0]							
0x33h	limp-home control	0x0Eh	limp_status	limp_exit[2:0]		Limp_timeout[0:2]			limp_cfg	

### 8.14.4.2 Diagnostic registers

[Table 34](#) provides an overview of the diagnostic registers. As the device continuously updates these registers, they do not have a default value.

**Table 34. Diagnostic register group overview**

Address	Name	7	6	5	4	3	2	1	0
0x20h	LED on voltage channel 1	V_LED1_on[7:0]							
0x21h	LED off voltage channel 1	V_LED1_off[7:0]							
0x22h	LED on voltage channel 2	V_LED2_on[7:0]							
0x23h	LED off voltage channel 2	V_LED2_off[7:0]							
0x26h	junction temperature	T_junction[7:0]							
0x34h	diagnostic register 4	-	-	-	-	-	-	BS_UV2	BS_UV1
0x35h	diagnostic register 3	-	-	-	CR0_CH2	CR0_CH1	-	LV_CH2	LV_CH1
0x36h	diagnostic register 2	-	1	-	NVM_fail	NWM_ok	-	PWM2	PWM1
0x37h	diagnostic register 1 (default read register)	VIN_Stat	SPI_er	Tj_er	VGG_er	VGG_ok	-	I-CH2	I-CH1
0x38h	VIN voltage measurement <sup>[1]</sup>	V_VIN[7:0]							

[1] A write to the VIN voltage measurement register sets the SPI error bit high.

### 8.14.4.3 NVM registers

[Table 35](#) provides an overview of the registers that control the NVM.

**Table 35. NVM register group overview**

Address	Name	7	6	5	4	3	2	1	0
0x17h	NVM control	NVM_read	NVM_write	-	NVM_address				
0x18h	NVM write data 1	NVM Data1[7:0]							
0x19h	NVM write data 2	NVM Data2[7:0]							
0x28h	NVM read data 1	NVM Data1[7:0]							
0x29h	NVM read data 2	NVM Data2[7:0]							

### 8.14.4.4 Internal registers

The ASL2417SHN uses the SPI registers to control some internal functions. In order to avoid any unintended behavior of the device, do not modify these registers but leave them all at their default value.

**Table 36. Internal register overview**

Address	Name	Default value	7	6	5	4	3	2	1	0
0x04h	Internal 1	0x17h	-	-	-	-	-	-	-	-
0x0Dh	Internal 2	0x03h	-	-	-	-	-	-	-	-
0x24h	Internal 3	0x00h	-	-	-	-	-	-	-	-
0x25h	Internal 4	0x00h	-	-	-	-	-	-	-	-

## 9. Limiting values

**Table 37. Limiting values**
*In accordance with the Absolute Maximum Rating System (IEC 60134).*

Symbol	Parameter	Conditions	Min	Max	Unit
V <sub>IN</sub>	voltage on pin VIN	EN = low	-0.3	+80	V
		EN = high	10	80	V
V <sub>VCC</sub>	voltage on pin VCC		-0.3	+5.5	V
V <sub>I(dig)</sub>	digital input voltage	voltage on pins SDO, SDI, CSB, SCLK, EN, PWM1, PWM2 and PWM3	-0.3	+5.5	V
V <sub>VGG</sub>	voltage on pin VGG		-0.3	+10	V
V <sub>LX</sub>	voltage on pin LX	LX1, LX2 and LX3	-1.0	+80	V
SR <sub>f(max)</sub>	maximum falling edge slew rate	on pins LX1, LX2 and LX3; at maximum input voltage	-	5.0	V/ns
V <sub>sense</sub>	sense voltage	voltage on sense pins RH1, RL1, RH2, RL2, RH3 and RL3	-1.0 <sup>[1]</sup>	+70 <sup>[2]</sup>	V
V <sub>RH-RL(max)</sub>	maximum voltage drop between pins RH and RL	maximum drop between the RH and RL pins of one channel	-0.3	+0.8	V
V <sub>BSx</sub>	voltage on bootstrap pins	BS1 and BS2	-0.3	+90	V
V <sub>Gx</sub>	voltage on gate pins	G1 and G2	-1.0	+90	V
ΔV <sub>max</sub>	maximum voltage difference	between pins G and LX of one channel	-	12	V
		between pins BS and LX of one channel	-	12	V
T <sub>j</sub>	junction temperature		-40	+175	°C
		during programming of NVM	0	+85	°C
T <sub>stg</sub>	storage temperature		-55	+175	°C
N <sub>endu(W_ER)</sub>	write or erase endurance	number of NVM programming cycles	-	200	
V <sub>ESD</sub>	electrostatic discharge voltage	HBM <sup>[3]</sup>			
		at any pin	-2	+2	kV
		at pins RLx with 100 nF at pin	-6	+6	kV
		IEC 61000-4-2 <sup>[4]</sup>			
		at pins RLx with 100 nF at pin	-6	+6	kV
CDM <sup>[5]</sup>	at any pin		-500	+500	V

[1] The limitation of the slew rate is an IC constraint. When the IC is operating in an application circuit, the external circuitry influences the slew rate capability. An example guideline for some specific MOSFET parameters to be considered when selecting the appropriate resistor values, can be found in the table below. Nonetheless, each application should be validated to determine the final solution when considering EMC performance and correct gate driver operation.

[2] 76 V for  $t \leq 10$  seconds guaranteed by design.

[3] Human Body Model (HBM): according to AEC-Q100-002 (100 pF, 1.5 kΩ).

[4] IEC 61000-4-2 (150 pF, 330 Ω).

[5] Charged Device Model (CDM): according to AEC-Q100-011 (field Induced charge; 4 pF).

9.1 External circuitry

Table 38. Guideline for external circuitry

Symbol	Component	MOSFET configuration typical values			Unit
		Config. 1	Config. 2	Config. 3	
R <sub>G</sub>	[1]	1.0	4.7	1.7	Ω
Q <sub>GS</sub>	[1]	0.6	1.2	0.8	nC
Q <sub>GD</sub>	[1]	0.9	1.8	1.2	nC
R <sub>DSon</sub>	[1]	175	80	72	mΩ
R <sub>gate</sub>	gate resistor	33	15	33	Ω
RL <sub>x</sub>	sense resistor low side channel	10	10	10	Ω
C5		1	1	1	μF

[1] MOSFET M5

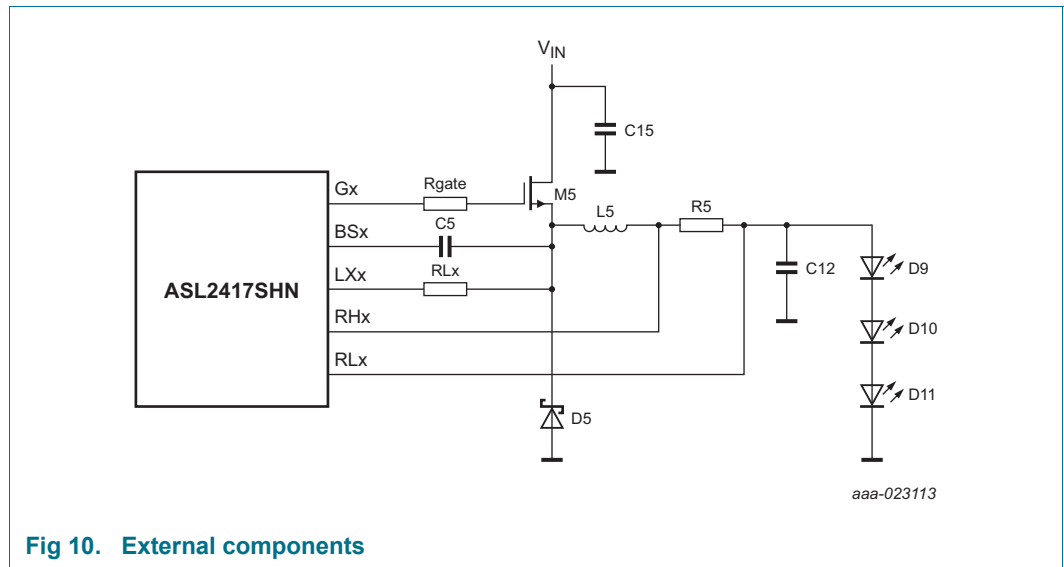

## 10. Thermal characteristics

### 10.1 Thermal model of the ASL2417SHN

The ASL2417SHN has several power sources on the die, but for thermal modeling they can be simplified to one generic power source.

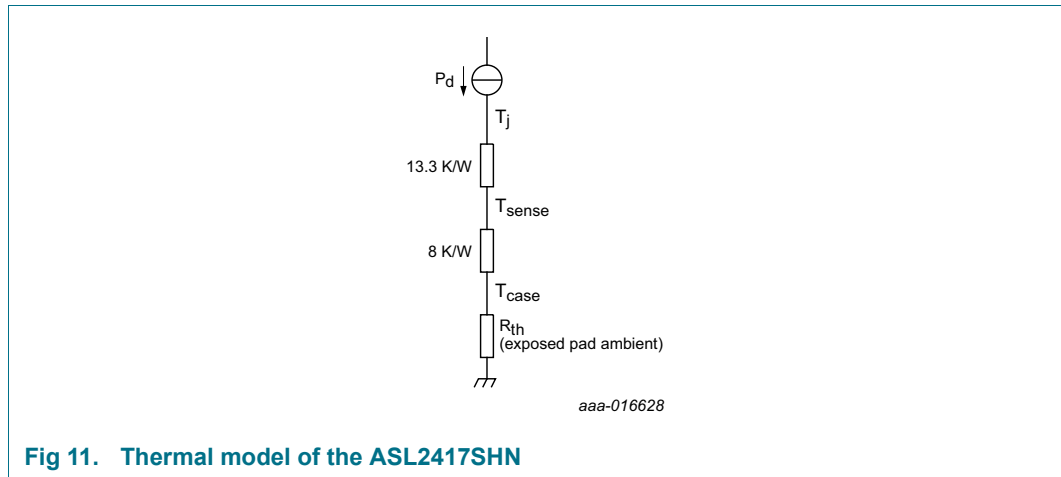

**Fig 11. Thermal model of the ASL2417SHN**

The power can be calculated using [Equation 4](#) and [Equation 5](#):

$$I_{\text{gates}} = f_{\text{sw1}} \times Q_{\text{g1}} + f_{\text{sw2}} \times Q_{\text{g2}} \quad (4)$$

$$P_d = V_{\text{Vin}} \times (3.5 \text{ mA} + 1.3 \text{ mA} \times \text{\#channels\_active} + I_{\text{gates}}) + V_{\text{VCC}} \times 10 \text{ mA} \quad (5)$$

Note, the  $T_{\text{sense}}$  is the location of the IC internal temperature measurement. The location of the sensor, makes it possible that the junction temperature has already exceeded 175 °C, even though the temperature measurement returns a value lower than 175 °C.

## 11. Static characteristics

**Table 39. Static characteristics**

Min and Max values are specified for the following conditions:  $V_{VIN} = 10\text{ V to }80\text{ V}$ ,  $V_{EN} = 4.5\text{ V to }5.5\text{ V}$ ,  $V_{VCC} = 4.5\text{ V to }5.5\text{ V}$  and  $T_j = -40\text{ }^\circ\text{C to }+175\text{ }^\circ\text{C}$ .<sup>[1]</sup> All voltages are defined with respect to ground, positive currents flow into the IC. Typical values are given at  $V_{VIN} = 40\text{ V}$ ,  $V_{EN} = 5\text{ V}$ ,  $V_{VCC} = 5\text{ V}$  and  $T_j = 25\text{ }^\circ\text{C}$  unless otherwise specified.

Symbol	Parameter	Conditions	Min	Typ	Max	Unit
$I_{DD}$	supply current	on pin VIN; operating no load on gate and VGG not set	-	3.5	10	mA
		current on pin EN when EN = high	-	-	150	$\mu\text{A}$
$I_{off}$	off-state current	EN = low; $V_{IN} < 12\text{ V}$	-	-	5	$\mu\text{A}$
<b>Supply pin VCC</b>						
$I_{VCC}$	supply current on pin VCC	EN = high; CSB = low	-	10	15	mA
$V_{UVLO(VCC)}$	undervoltage lockout on pin VCC	<sup>[2]</sup>	3.7	-	4.4	V
<b>Enable pin EN</b>						
$V_{UVLO(EN)}$	undervoltage lockout on pin EN	<sup>[2]</sup>	3.7	-	4.4	V
<b>LED output characteristics</b>						
$V_{O(LED)}$	LED output voltage	LED1; $V_{IN} \geq V_{O(LED)} + V_{hr(low)}$	2.5	-	70	V
		LED2; $V_{IN} \geq V_{O(LED)} + V_{hr(low)}$	2.5	-	70	V
$V_{O(min)}$	minimum output voltage	average values				
		setting 0	5	-	11	mV
		setting 1	13	-	21	mV
		setting 2	22	-	31	mV
		setting 3	32	-	42	mV
$I_{O(LED)}$	LED output current	nominal average; $V_{O(LED)} = 2.5\text{ V to }70\text{ V}$ ; $V_{IN} \geq V_{O(LED)} + V_{off(hr)low}$ ; $R_{sense} = 200\text{ m}\Omega$	$V_{O(min)}/R_{sense}$	-	1500	mA
$V_{sense(AV)acc}$	average sense voltage accuracy	$I_{CHx} = 1$ ; $V_{sense(AV)} \geq 24\text{ mV}$ <sup>[3]</sup>	-4	-	+4	%
		$I_{CHx} = 0$ ; $V_{sense(AV)} \geq 120\text{ mV}$ <sup>[3]</sup>	-4	-	+4	%
$V_{O(acc)}$	output voltage accuracy	related to currently applied value	$-0.02 \times V_{LEDx} - 1.0644\text{ V}$	-	$+0.02 \times V_{LEDx} + 1.0644\text{ V}$	%
			$-0.02 \times V_{VIN} - 1.0644\text{ V}$	-	$+0.02 \times V_{VIN} + 1.0644\text{ V}$	%
$V_{off(hr)low}$	low headroom turn-off voltage	$V_{IN} - V_{O(LED)}$	5	-	7	V
$V_{ocp}$	overcurrent protection voltage		-	400	-	mV
<b>VGG output characteristics (<math>C_{VGG} = 1\text{ }\mu\text{F}</math>, <math>ESR \leq 0.1\text{ }\Omega</math>)</b>						
$V_{O(reg)}$	regulator output voltage		4.5	-	10.04	V
$V_{O(reg)acc}$	regulator output voltage accuracy		-5	-	+5	%
$V_{do(reg)}$	regulator dropout voltage	$I_{reg} \leq 50\text{ mA}$ ; regulator in saturation	-	0.5	1.0	V
		$I_{reg} \leq 160\text{ mA}$ ; regulator in saturation	-	1.6	3.2	V



**Table 39. Static characteristics ...continued**

Min and Max values are specified for the following conditions:  $V_{VIN} = 10\text{ V to }80\text{ V}$ ,  $V_{EN} = 4.5\text{ V to }5.5\text{ V}$ ,  $V_{VCC} = 4.5\text{ V to }5.5\text{ V}$  and  $T_j = -40\text{ }^\circ\text{C to }+175\text{ }^\circ\text{C}$ . [1] All voltages are defined with respect to ground, positive currents flow into the IC. Typical values are given at  $V_{VIN} = 40\text{ V}$ ,  $V_{EN} = 5\text{ V}$ ,  $V_{VCC} = 5\text{ V}$  and  $T_j = 25\text{ }^\circ\text{C}$  unless otherwise specified.

Symbol	Parameter	Conditions	Min	Typ	Max	Unit
<b>Bootstrap characteristics; pins BS1 and BS2 (capacitance between BS and LX pins = 1 <math>\mu\text{F}</math>)</b>						
$V_{d(bs)}$	bootstrap diode voltage	$I_{bs} \leq 100\text{ mA}$	-	-	1.5	V
$I_{bs}$	bootstrap current	current consumption of gate driver; output is turned on	-	300	-	$\mu\text{A}$
$V_{th(bs)OV}$	bootstrap overvoltage detection threshold		5.5	-	8	V
$V_{th(bs)UV}$	bootstrap undervoltage detection threshold		3.5	4.5	5.3	V
<b>PWM inputs; pins PWM1 and PWM2</b>						
$V_{th(sw)}$	switching threshold voltage		0.7	-	3.5	V
$R_{pd(int)}$	internal pull-down resistance		50	-	130	$\text{k}\Omega$
<b>Serial peripheral interface inputs; pins SDI, SCLK and CSB</b>						
$V_{th(sw)}$	switching threshold voltage		0.7	-	3.5	V
$V_{th(sw)hys}$	switching threshold voltage hysteresis		0.1	-	1.1	V
$I_{IL}$	LOW-level input current		-10	-	+10	$\mu\text{A}$
$I_{IH}$	HIGH-level input current		15	40	110	$\mu\text{A}$
$R_{pd(int)SCLK}$	internal pull-down resistance on pin SCLK		50	-	130	$\text{k}\Omega$
$R_{pd(int)CSB}$	internal pull-down resistance on pin CSB		50	-	130	$\text{k}\Omega$
$R_{pd(int)SDI}$	internal pull-down resistance on pin SDI		50	-	130	$\text{k}\Omega$
<b>Serial peripheral interface data output; pin SDO</b>						
$V_{OH}$	HIGH-level output voltage	$I_{OH} = -4\text{ mA}$	$0.9 \times V_{VCC}$	-	-	V
$V_{OL}$	LOW-level output voltage	$I_{OL} = 4\text{ mA}$	-	-	$0.1 \times V_{VCC}$	V
$I_{OH}$	HIGH-level output current		-30.0	-	-1.6	$\text{mA}$
$I_{OL}$	LOW-level output current		1.6	-	30.0	$\text{mA}$
$I_{LOZ}$	OFF-state output leakage current	$V_{CSB} = V_{VCC}$ ; $V_O = 0\text{ V to }V_{VCC}$	-5	-	+5	$\mu\text{A}$
<b>Temperature protection</b>						
$T_{sd(otp)}$	overtemperature protection shutdown temperature		165	175	185	$^\circ\text{C}$
$\Delta T_j$	junction temperature deviation	$T_j = 130\text{ }^\circ\text{C}$ ; measurement provided via register 0x26h [4]	-5	-	+5	$^\circ\text{C}$

- [1] All parameters are guaranteed over the virtual junction temperature range by design. Factory testing uses correlated test conditions to cover the specified temperature and power supply voltage range.
- [2] Undervoltage lockout pulls the gate pins low but the other functions of the IC remain operational.
- [3] Excluding influence of load and line regulation due to total delay of gate driver and comparators of hysteretic converter.
- [4] Guaranteed by wafer testing at 125  $^\circ\text{C}$ .

## 12. Dynamic characteristics

**Table 40. Dynamic characteristics**

Min and Max values are specified for the following conditions:  $V_{VIN} = 10\text{ V to }80\text{ V}$ ,  $V_{EN} = 4.5\text{ V to }5.5\text{ V}$ ,  $V_{VCC} = 4.5\text{ V to }5.5\text{ V}$  and  $T_j = -40\text{ }^\circ\text{C to }+175\text{ }^\circ\text{C}$ . All voltages are defined with respect to ground, positive currents flow into the IC. Typical values are given at  $V_{VIN} = 40\text{ V}$ ,  $V_{EN} = 5\text{ V}$  and  $V_{VCC} = 5\text{ V}$ , unless otherwise specified.

Symbol	Parameter	Conditions	Min	Typ	Max	Unit
$f_{\text{PWM}}$	PWM frequency		100	-	1000	Hz
$\Delta_{\text{PWM}}$	PWM duty cycle		0	-	100	%
$t_{\text{d(on)PWM}}$	PWM turn-on delay time	90 % of LED current	-	-	100	$\mu\text{s}$
$t_{\text{d(off)PWM}}$	PWM turn-off delay time	10 % of LED current	-	-	100	$\mu\text{s}$
$t_{\text{d(i)PWM}}$	PWM input delay time	including start-up time of the boost	-	20	-	ms
$f_{\text{DCDC}}$	DC-to-DC frequency		100	-	2000	kHz
$t_{\text{on(drv)G(max)}}$	maximum on time of one gate driver		-	1	-	ms
$t_{\text{d(drv)G}}$	gate driver delay time	total delay of gate driver and comparators of hysteretic converter <a href="#">[1]</a>	25	-	75	ns
		total delay of gate driver and comparators of hysteretic converter <a href="#">[2]</a>	10	-	75	ns
$t_{\text{blank}}$	blanking time	of sense amplifier after switching	70	-	130	ns
$t_{\text{off(drv)G(min)}}$	minimum off time of one gate driver		-	125	-	ns
<b>Serial peripheral interface timing; pins CSB, SCLK, SDI and SDO</b>						
$t_{\text{cy(clk)}}$	clock cycle time		285	-	-	ns
$t_{\text{SPILEAD}}$	SPI enable lead time		140	-	-	ns
$t_{\text{SPILAG}}$	SPI enable lag time		140	-	-	ns
$t_{\text{clk(H)}}$	clock HIGH time		140	-	-	ns
$t_{\text{clk(L)}}$	clock LOW time		140	-	-	ns
$t_{\text{su(D)}}$	data input setup time		50	-	-	ns
$t_{\text{h(D)}}$	data input hold time		50	-	-	ns
$t_{\text{v(Q)}}$	data output valid time	pin SDO; CL = 50 pF	-	-	130	ns
$t_{\text{WH(S)}}$	chip select pulse width HIGH		285	-	-	ns
$t_{\text{d(SPI)}}$	SPI delay time	after leaving OFF mode; EN = 0 V $\rightarrow$ 5 V	-	-	100	$\mu\text{s}$
$t_{\text{rst(reg)}}$	register reset time	time to reset all registers to default value; EN = 0 V $\rightarrow$ 5 V	-	-	400	$\mu\text{s}$
<b>Gate driver characteristics for pins G1 and G2</b>						
$t_{\text{ch(G)}}$	gate charge time	20 % to 80 %; $V_{\text{bsx}} - \text{LXx} = 10\text{ V}$ ; CG = 1000 pF	-	-	50	ns
$t_{\text{dch(G)}}$	gate discharge time	20 % to 80 %; $V_{\text{bsx}} - \text{LXx} = 10\text{ V}$ ; CG = 1000 pF	-	-	25	ns
$t_{\text{p}}$	pulse duration	applies to BS pins				
		recharge pulse time	-	80	-	$\mu\text{s}$
		period for recharge pulses	-	360	-	$\mu\text{s}$

**Table 40. Dynamic characteristics ...continued**

Min and Max values are specified for the following conditions:  $V_{VIN} = 10\text{ V to }80\text{ V}$ ,  $V_{EN} = 4.5\text{ V to }5.5\text{ V}$ ,  $V_{VCC} = 4.5\text{ V to }5.5\text{ V}$  and  $T_j = -40\text{ }^\circ\text{C to }+175\text{ }^\circ\text{C}$ . All voltages are defined with respect to ground, positive currents flow into the IC. Typical values are given at  $V_{VIN} = 40\text{ V}$ ,  $V_{EN} = 5\text{ V}$  and  $V_{VCC} = 5\text{ V}$ , unless otherwise specified.

Symbol	Parameter	Conditions	Min	Typ	Max	Unit
<b>Voltage measurements</b>						
$t_{meas}$	measurement time	period for voltage measurements at VIN	-	15	-	$\mu\text{s}$
		period for voltage measurements at outputs	-	80	-	$\mu\text{s}$
		period for sampling low headroom detection at outputs	-	8	-	$\mu\text{s}$
$t_{meas(LED)}$	LED measurement time	period for the LED voltage measurement update when the PWM pin is static	-	16	-	ms
<b>VGG characteristics</b>						
$t_{err(startup)}$	start-up error time	time to detect an error on VGG at start-up	-	20.2	-	ms
$t_{err(oper)}$	operation error time	time to detect an error on VGG during operation	-	200	-	$\mu\text{s}$
<b>Limp-home mode timing</b>						
$t_{to(limp)}$	limp time-out time	Limp-home mode time-out time				
		setting 1	4.72	5.02	5.3	ms
		setting 2	9.53	10	10.6	ms
		setting 3	19.1	20.2	21.2	ms
		setting 4	38.3	40.4	42.5	ms
		setting 5	76.7	80.9	84.9	ms
		setting 6	153	162	170	ms
		setting 7	307	324	340	ms
		setting 8	614	647	680	ms

[1] Lower hysteresis trip point until external FET is turned on.

[2] Higher hysteresis trip point until external FET is turned off.

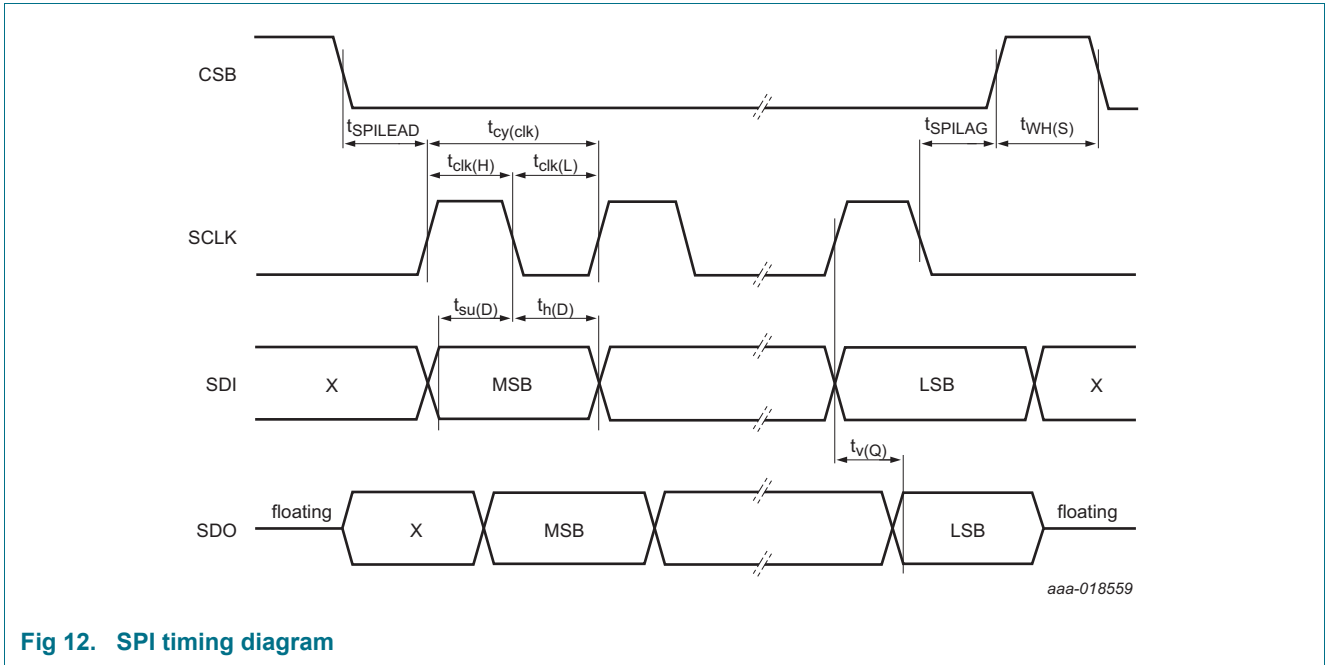

Fig 12. SPI timing diagram

### 13. Application information

Figure 13 provides an example for the ASL2417SHN in a typical external front lighting application driving 2 independent LED strings.

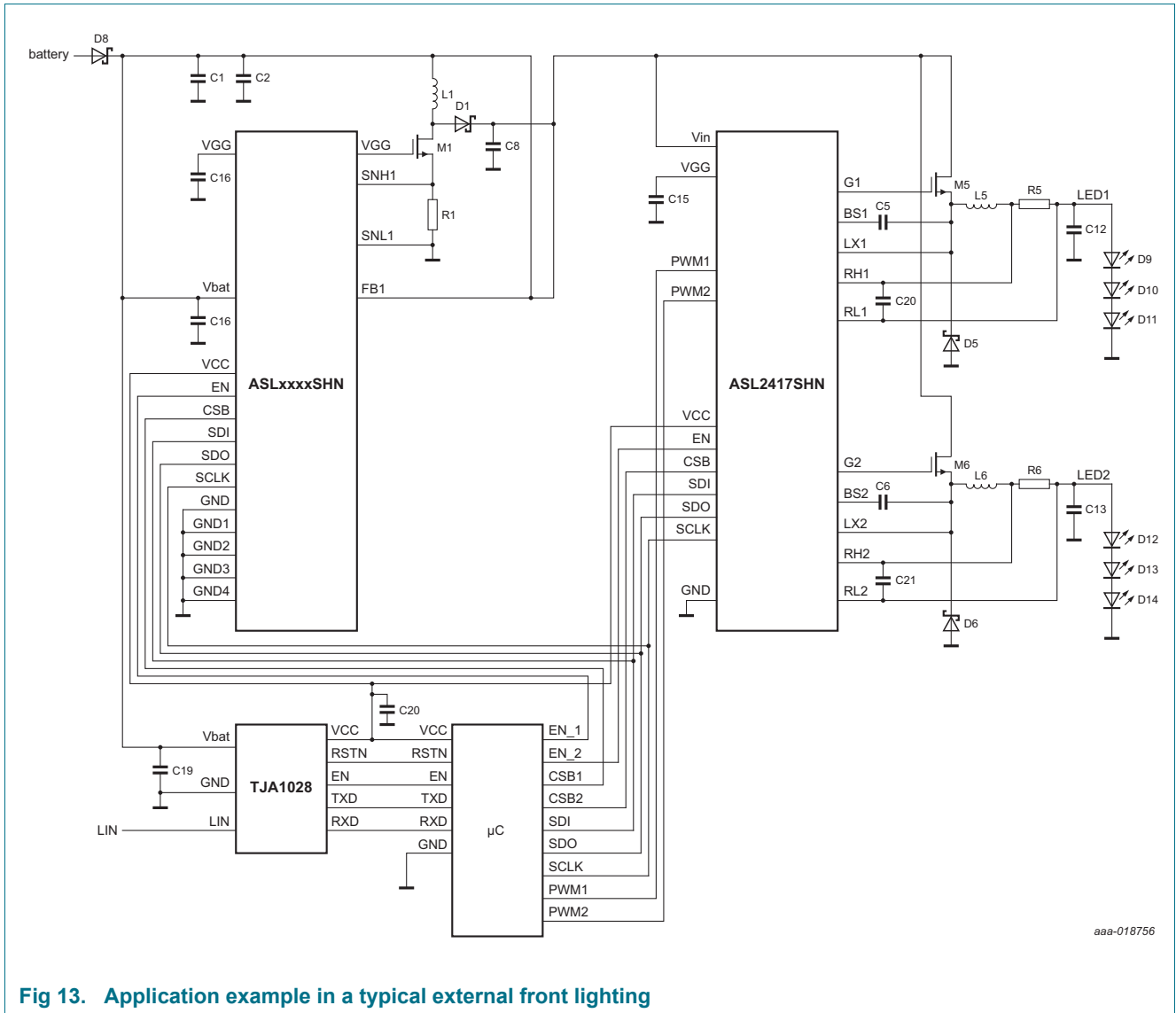

Fig 13. Application example in a typical external front lighting

### 14. Test information

#### 14.1 Quality information

This product has been qualified in accordance with the Automotive Electronics Council (AEC) standard Q100 - Failure mechanism-based stress test qualification for integrated circuits. It is suitable for use in automotive applications.

15. Package outline

HVQFN32: plastic thermal enhanced very thin quad flat package; no leads;  
32 terminals; body 5 x 5 x 0.85 mm

SOT617-12

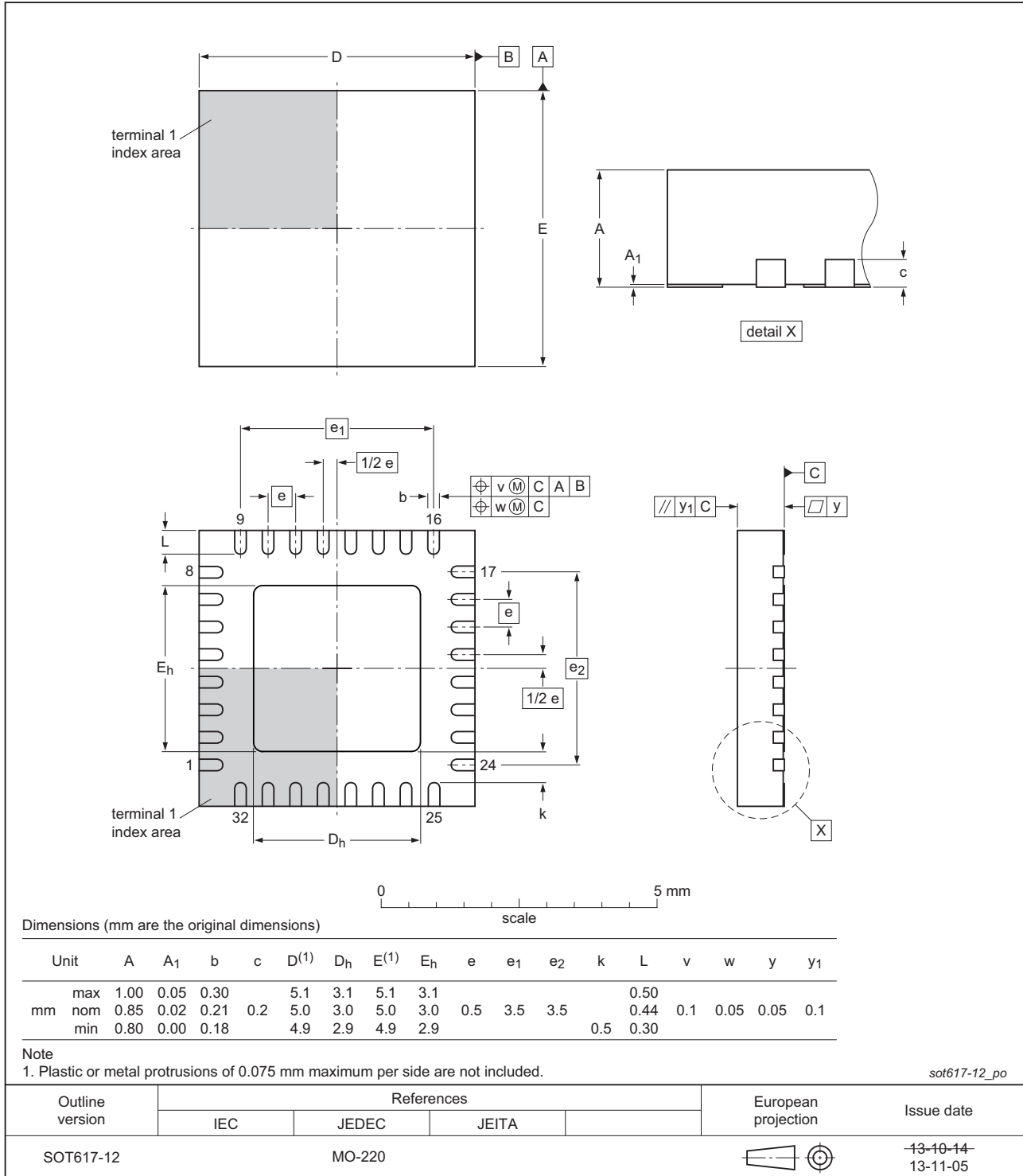

Fig 14. Package outline HVQFN32

## 16. Revision history

Table 41. Revision history

Document ID	Release date	Data sheet status	Change notice	Supersedes
ASL2417SHN v.4	20190916	Product data sheet	-	ASL2417SHN v.3
Modifications:	<ul style="list-style-type: none"> <li>• <a href="#">Section 8.5.1</a>: corrected results in calculation example</li> <li>• <a href="#">Table 15</a>: changed formula for VGG setting</li> <li>• <a href="#">Table 33</a>: adapt reset values for a more robust start of the limp-home functionality</li> <li>• <a href="#">Table 39</a>: clarified minimum LED output current</li> </ul>			
ASL2417SHN v.3	20171026	Product data sheet	-	ASL2417SHN v.2
Modifications:	<ul style="list-style-type: none"> <li>• Section 8.13.6: the SPI register address changed in list item 4 and list item 5</li> <li>• Section 8.9: clarified exceeding of limiting values</li> </ul>			
ASL2417SHN v.2	20170222	Product data sheet	-	ASL2417SHN v.1
Modifications:	<ul style="list-style-type: none"> <li>• Formula for voltage conversion updated</li> <li>• Figure 11: updated</li> <li>• Equation 4 and Equation 5: updated</li> <li>• Table 39: maximum value for low headroom turn-off voltage changed</li> </ul>			
ASL2417SHN v.1	20160603	Product data sheet	-	-

## 17. Legal information

### 17.1 Data sheet status

Document status <sup>[1][2]</sup>	Product status <sup>[3]</sup>	Definition
Objective [short] data sheet	Development	This document contains data from the objective specification for product development.
Preliminary [short] data sheet	Qualification	This document contains data from the preliminary specification.
Product [short] data sheet	Production	This document contains the product specification.

[1] Please consult the most recently issued document before initiating or completing a design.

[2] The term 'short data sheet' is explained in section "Definitions".

[3] The product status of device(s) described in this document may have changed since this document was published and may differ in case of multiple devices. The latest product status information is available on the Internet at URL <http://www.nxp.com>.

### 17.2 Definitions

**Draft** — The document is a draft version only. The content is still under internal review and subject to formal approval, which may result in modifications or additions. NXP Semiconductors does not give any representations or warranties as to the accuracy or completeness of information included herein and shall have no liability for the consequences of use of such information.

**Short data sheet** — A short data sheet is an extract from a full data sheet with the same product type number(s) and title. A short data sheet is intended for quick reference only and should not be relied upon to contain detailed and full information. For detailed and full information see the relevant full data sheet, which is available on request via the local NXP Semiconductors sales office. In case of any inconsistency or conflict with the short data sheet, the full data sheet shall prevail.

**Product specification** — The information and data provided in a Product data sheet shall define the specification of the product as agreed between NXP Semiconductors and its customer, unless NXP Semiconductors and customer have explicitly agreed otherwise in writing. In no event however, shall an agreement be valid in which the NXP Semiconductors product is deemed to offer functions and qualities beyond those described in the Product data sheet.

### 17.3 Disclaimers

**Limited warranty and liability** — Information in this document is believed to be accurate and reliable. However, NXP Semiconductors does not give any representations or warranties, expressed or implied, as to the accuracy or completeness of such information and shall have no liability for the consequences of use of such information. NXP Semiconductors takes no responsibility for the content in this document if provided by an information source outside of NXP Semiconductors.

In no event shall NXP Semiconductors be liable for any indirect, incidental, punitive, special or consequential damages (including - without limitation - lost profits, lost savings, business interruption, costs related to the removal or replacement of any products or rework charges) whether or not such damages are based on tort (including negligence), warranty, breach of contract or any other legal theory.

Notwithstanding any damages that customer might incur for any reason whatsoever, NXP Semiconductors' aggregate and cumulative liability towards customer for the products described herein shall be limited in accordance with the *Terms and conditions of commercial sale* of NXP Semiconductors.

**Right to make changes** — NXP Semiconductors reserves the right to make changes to information published in this document, including without limitation specifications and product descriptions, at any time and without notice. This document supersedes and replaces all information supplied prior to the publication hereof.

**Suitability for use in automotive applications** — This NXP Semiconductors product has been qualified for use in automotive applications. Unless otherwise agreed in writing, the product is not designed, authorized or warranted to be suitable for use in life support, life-critical or safety-critical systems or equipment, nor in applications where failure or malfunction of an NXP Semiconductors product can reasonably be expected to result in personal injury, death or severe property or environmental damage. NXP Semiconductors and its suppliers accept no liability for inclusion and/or use of NXP Semiconductors products in such equipment or applications and therefore such inclusion and/or use is at the customer's own risk.

**Applications** — Applications that are described herein for any of these products are for illustrative purposes only. NXP Semiconductors makes no representation or warranty that such applications will be suitable for the specified use without further testing or modification.

Customers are responsible for the design and operation of their applications and products using NXP Semiconductors products, and NXP Semiconductors accepts no liability for any assistance with applications or customer product design. It is customer's sole responsibility to determine whether the NXP Semiconductors product is suitable and fit for the customer's applications and products planned, as well as for the planned application and use of customer's third party customer(s). Customers should provide appropriate design and operating safeguards to minimize the risks associated with their applications and products.

NXP Semiconductors does not accept any liability related to any default, damage, costs or problem which is based on any weakness or default in the customer's applications or products, or the application or use by customer's third party customer(s). Customer is responsible for doing all necessary testing for the customer's applications and products using NXP Semiconductors products in order to avoid a default of the applications and the products or of the application or use by customer's third party customer(s). NXP does not accept any liability in this respect.

**Limiting values** — Stress above one or more limiting values (as defined in the Absolute Maximum Ratings System of IEC 60134) will cause permanent damage to the device. Limiting values are stress ratings only and (proper) operation of the device at these or any other conditions above those given in the Recommended operating conditions section (if present) or the Characteristics sections of this document is not warranted. Constant or repeated exposure to limiting values will permanently and irreversibly affect the quality and reliability of the device.

**Terms and conditions of commercial sale** — NXP Semiconductors products are sold subject to the general terms and conditions of commercial sale, as published at <http://www.nxp.com/profile/terms>, unless otherwise agreed in a valid written individual agreement. In case an individual agreement is concluded only the terms and conditions of the respective agreement shall apply. NXP Semiconductors hereby expressly objects to applying the customer's general terms and conditions with regard to the purchase of NXP Semiconductors products by customer.



**No offer to sell or license** — Nothing in this document may be interpreted or construed as an offer to sell products that is open for acceptance or the grant, conveyance or implication of any license under any copyrights, patents or other industrial or intellectual property rights.

**Export control** — This document as well as the item(s) described herein may be subject to export control regulations. Export might require a prior authorization from competent authorities.

**Translations** — A non-English (translated) version of a document is for reference only. The English version shall prevail in case of any discrepancy between the translated and English versions.

**Security** — While NXP Semiconductors has implemented advanced security features, all products may be subject to unidentified vulnerabilities. Customers are responsible for the design and operation of their applications and products to reduce the effect of these vulnerabilities on customer's applications and products, and NXP Semiconductors accepts no liability for any vulnerability that is discovered. Customers should implement appropriate design and operating safeguards to minimize the risks associated with their applications and products.

## 17.4 Trademarks

Notice: All referenced brands, product names, service names and trademarks are the property of their respective owners.

## 18. Contact information

---

For more information, please visit: <http://www.nxp.com>

For sales office addresses, please send an email to: [salesaddresses@nxp.com](mailto:salesaddresses@nxp.com)

## 19. Tables

Table 1.	Ordering information	3	Table 20.	Diagnostic register 2, address 0x36h	16
Table 2.	Pin description <sup>[1]</sup>	4	Table 21.	Diagnostic register 3, address 0x35h	18
Table 3.	VIN voltage measurement register, address 0x38h <sup>[1]</sup>	7	Table 22.	BS_UV register - read access, address 0x34h	18
Table 4.	Undervoltage threshold register, address 0x0Fh	7	Table 23.	BS_UV register - write access, address 0x34h	18
Table 5.	LED current range register, address 0x05h	8	Table 24.	Limp-home state overview	19
Table 6.	LED current channel 1 register, address 0x02h	8	Table 25.	Limp-home mode deactivation sequence	20
Table 7.	LED current channel 2 register, address 0x03h	8	Table 26.	Limp-home mode control register, address 0x33h	21
Table 8.	Hysteresis channel 1 register, address 0x0Bh	9	Table 27.	Mapping of NVM registers to control registers	22
Table 9.	Hysteresis channel 2 register, address 0x0Ch	9	Table 28.	Overview of multi-content NVM data fields	22
Table 10.	LED on voltage channel 1 register, address 0x20h	10	Table 29.	NVM_PWMx bits	23
Table 11.	LED off voltage channel 1 register, address 0x21h	10	Table 30.	SPI frame format for a transition to the device	24
Table 12.	LED on voltage channel 2 register, address 0x22h	10	Table 31.	SPI frame format for a transition from the device	24
Table 13.	LED off voltage channel 2 register, address 0x23h	11	Table 32.	Grouping of the register space	26
Table 14.	Function control register, address 0x00h	12	Table 33.	Control register group overview	27
Table 15.	VGG control register, address 0x01h	12	Table 34.	Diagnostic register group overview	27
Table 16.	Junction temperature register, address 0x26h	13	Table 35.	NVM register group overview	28
Table 17.	Diagnostic register 1, address 0x37h	14	Table 36.	Internal register overview	28
Table 18.	Effect of VIN_stat on device functionality	14	Table 37.	Limiting values	29
Table 19.	CR copy pulse register, address 0x06h	16	Table 38.	Guideline for external circuitry	30
			Table 39.	Static characteristics	32
			Table 40.	Dynamic characteristics	34
			Table 41.	Revision history	39

## 20. Figures

Fig 1.	Block diagram	3
Fig 2.	Pin configuration	4
Fig 3.	State diagram	6
Fig 4.	Limp-home state diagram	19
Fig 5.	SPI timing protocol	23
Fig 6.	SPI frame format	24
Fig 7.	Daisy chain configuration	25
Fig 8.	Physical parallel slave connection	25
Fig 9.	SPI frame format	26
Fig 10.	External components	30
Fig 11.	Thermal model of the ASL2417SHN	31
Fig 12.	SPI timing diagram	36
Fig 13.	Application example in a typical external front lighting	37
Fig 14.	Package outline HVQFN32	38

## 21. Contents

<b>1</b>	<b>Introduction</b>	<b>1</b>	8.12.3.1	Low voltage headroom warning	17
<b>2</b>	<b>General description</b>	<b>1</b>	8.12.3.2	Output current state	17
<b>3</b>	<b>Features and benefits</b>	<b>2</b>	8.12.3.3	Register content	18
<b>4</b>	<b>Applications</b>	<b>2</b>	8.12.4	Diagnostic register 4	18
<b>5</b>	<b>Ordering information</b>	<b>3</b>	8.12.4.1	Bootstrap undervoltage detection	18
<b>6</b>	<b>Block diagram</b>	<b>3</b>	8.13	Limp-home mode	19
<b>7</b>	<b>Pinning information</b>	<b>4</b>	8.13.1	Limp-home mode activation	20
7.1	Pinning	4	8.13.2	Limp-home mode operation	20
7.2	Pin description	4	8.13.3	Limp-home mode deactivation	20
<b>8</b>	<b>Functional description</b>	<b>6</b>	8.13.4	Limp-home mode control register	21
8.1	Operating modes	6	8.13.5	NVM Write Sequence	21
8.1.1	Off mode	6	8.13.6	NVM read sequence	21
8.1.2	Operation mode	6	8.13.7	NVM register map	22
8.1.3	Under voltage mode	6	8.14	SPI	23
8.1.4	Fail silent mode	6	8.14.1	Introduction	23
8.2	Buck converter	7	8.14.2	Typical use case illustration (write/read)	26
8.3	Input voltage measurement	7	8.14.3	Diagnostics for the SPI interface	26
8.4	Input under voltage detection	7	8.14.4	Register map	26
8.5	Output current programmability	7	8.14.4.1	Control registers	27
8.5.1	Output target current programming	7	8.14.4.2	Diagnostic registers	27
8.5.2	Hysteresis programming via SPI	8	8.14.4.3	NVM registers	28
8.5.3	Overcurrent protection	10	8.14.4.4	Internal registers	28
8.5.4	Output diagnostics	10	<b>9</b>	<b>Limiting values</b>	<b>29</b>
8.6	Output voltage measurement	10	9.1	External circuitry	30
8.7	External PWM input	11	<b>10</b>	<b>Thermal characteristics</b>	<b>31</b>
8.7.1	Control for PWM pins	11	10.1	Thermal model of the ASL2417SHN	31
8.7.2	Diagnostics for PWM functionality	11	<b>11</b>	<b>Static characteristics</b>	<b>32</b>
8.8	Function control register	11	<b>12</b>	<b>Dynamic characteristics</b>	<b>34</b>
8.9	Gate voltage supply	12	<b>13</b>	<b>Application information</b>	<b>37</b>
8.10	Junction temperature information	13	<b>14</b>	<b>Test information</b>	<b>37</b>
8.11	Bootstrap recharge mechanism	13	14.1	Quality information	37
8.11.1	Bootstrap charge maintaining	13	<b>15</b>	<b>Package outline</b>	<b>38</b>
8.12	Diagnostic information	14	<b>16</b>	<b>Revision history</b>	<b>39</b>
8.12.1	Diagnostic Register 1	14	<b>17</b>	<b>Legal information</b>	<b>40</b>
8.12.1.1	Bit VIN_stat	14	17.1	Data sheet status	40
8.12.1.2	Bit SPI_err	15	17.2	Definitions	40
8.12.1.3	Bit Tj_err	15	17.3	Disclaimers	40
8.12.1.4	Bit VGG_err	15	17.4	Trademarks	41
8.12.1.5	Bit VGG_ok	15	<b>18</b>	<b>Contact information</b>	<b>41</b>
8.12.1.6	Bits I-Ch1 and I-CH2	15	<b>19</b>	<b>Tables</b>	<b>42</b>
8.12.1.7	CR copy pulse	16	<b>20</b>	<b>Figures</b>	<b>42</b>
8.12.2	Diagnostic register 2	16	<b>21</b>	<b>Contents</b>	<b>43</b>
8.12.2.1	Bit NVM_fail	16			
8.12.2.2	Bit NVM_ok	16			
8.12.2.3	PWM toggle information (bits PWM1 and PWM2)	17			
8.12.3	Diagnostic register 3	17			

Please be aware that important notices concerning this document and the product(s) described herein, have been included in section 'Legal information'.