

THIS DRAWING IS UNPUBLISHED. RELEASED FOR PUBLICATION .19 .  
 © COPYRIGHT 19 BY AMP INCORPORATED. ALL RIGHTS RESERVED.

LOC		DIST		REVISIONS					
DY		-		P	LTR	DESCRIPTION	DATE	DWN	APVD
				F1		REVISED ECR-15-005119	07APR2014	I.T	W.H

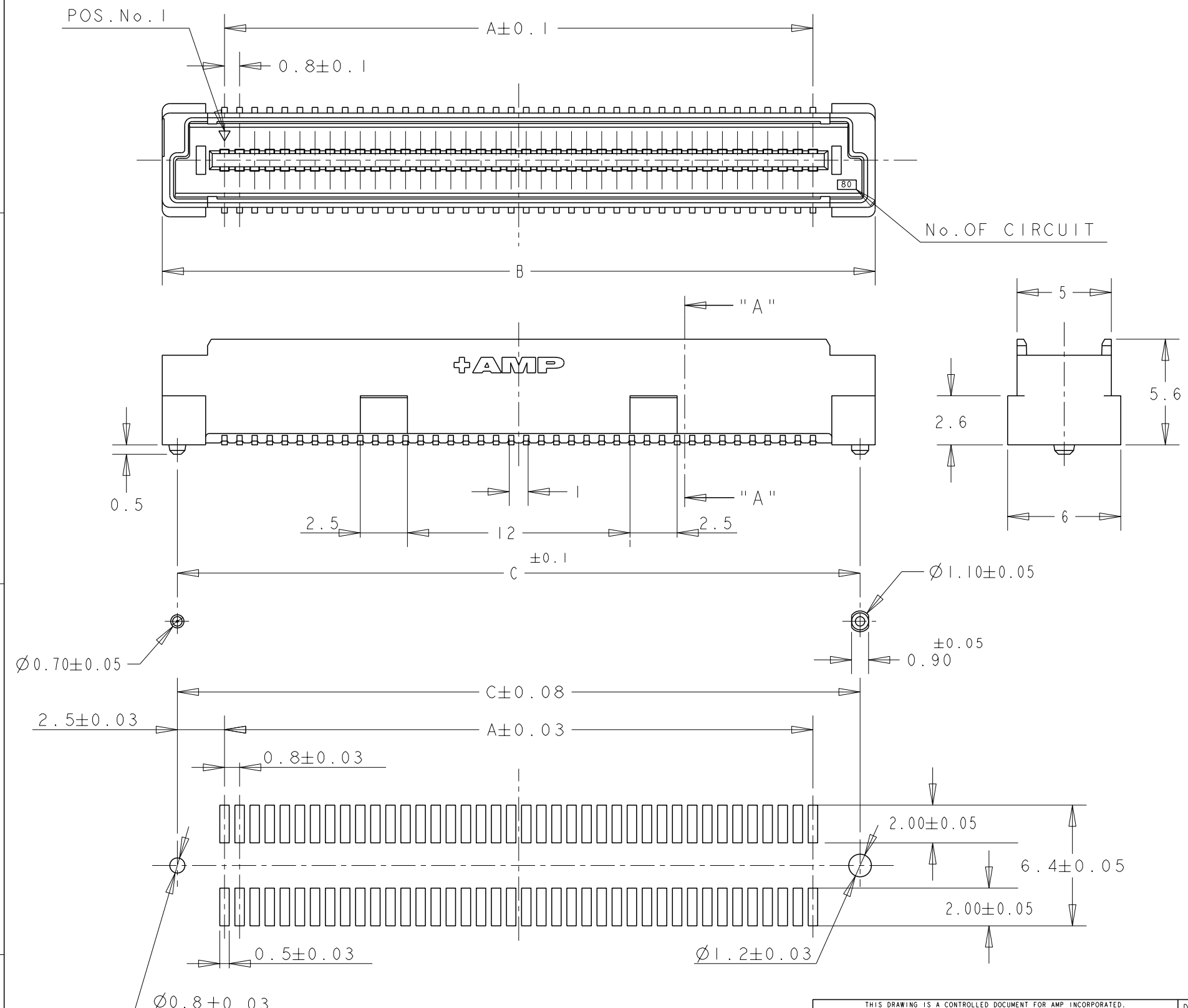

NOTES;

- 1. MATERIAL: HOUSING: L.C.P. (HIGH TEMP THERMO PLASTIC)  
UL 94V-0, NATURAL.  
CONTACT: BRASS.
- 2. FINISH: CONTACT AREA: 0.00076 MIN GOLD ON  
0.0013 MIN ALL OVER NICKEL.  
SOLDERING AREA: 0.001 MIN TIN-LEAD.
- 3. POSITION SERIES; SEE TABLE. (SHEET 2)
- 4. CONN STACK HEIGHT COMBINE OF PLUG "Y" H VS REC "X" H.  
STACK HEIGHT = Y + X - 5
- 5. FOR STEEL COVER PICK AND PLACE VERSION,  
DESCRIPTION PRINTING ON TUBE IS:  
"PLUG ASS'Y (H=6mm), W/ STEEL COVER,  
0.8mm BTB STACKING CONN"

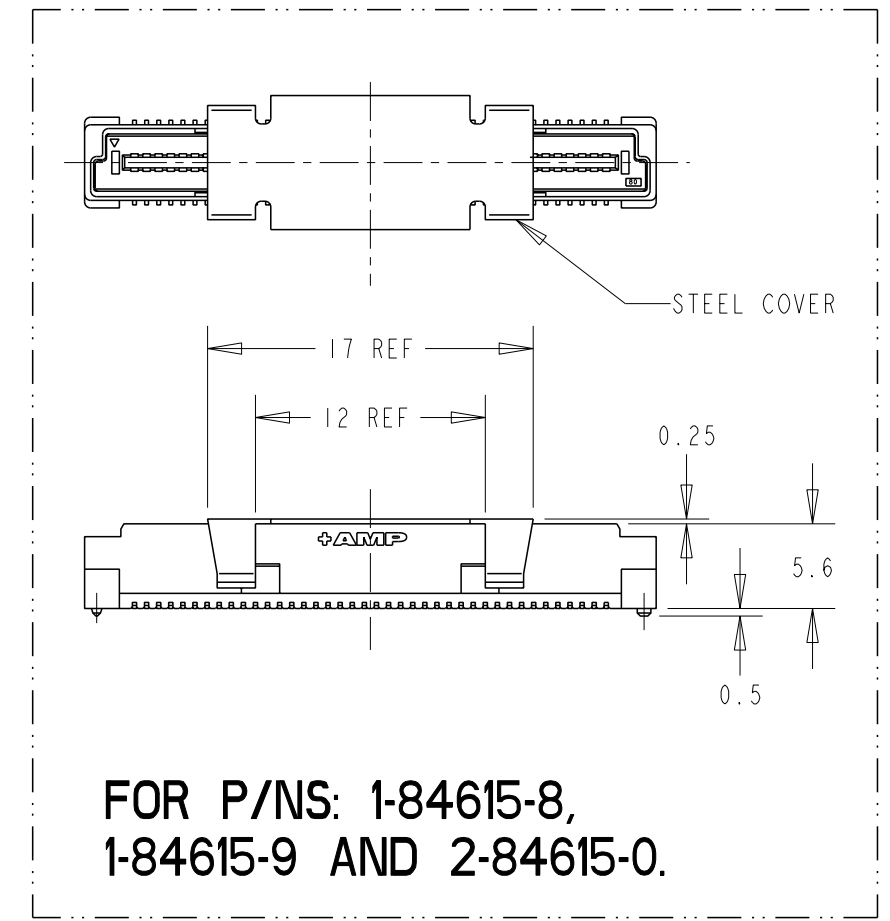

RECOMMENDED P.C. BOARD LAYOUT

P/N SEE SHEET 2 OF 2.

THIS DRAWING IS A CONTROLLED DOCUMENT FOR AMP INCORPORATED. IT IS SUBJECT TO CHANGE AND THE CONTROLLING ENGINEERING ORGANIZATION SHOULD BE CONTACTED FOR THE LATEST REVISION.		DWN	80CT98		<b>AMP</b>	AMP MANUFACTURING (SINGAPORE) PTE. LTD.	
DIMENSIONS: mm		CHK	WYLEE			NAME	
TOLERANCES UNLESS OTHERWISE SPECIFIED:		APVD	MARCUS		PLUG ASSEMBLY 6H TYPE 30Au (0.5 BOSS LENGTH) FOR FH 0.8mm PITCH B-T-B CONNECTOR		
0 PLC ±		PRODUCT SPEC	ERIC ING		SIZE	CAGE CODE	DRAWING NO
1 PLC ±0.2		APPLICATION SPEC	108-5390		A3	00779	©=84615
2 PLC ±0.25		WEIGHT	114-5254		SCALE 4:1 SHEET 1 OF 2 REV F1		
3 PLC ±0.3		CUSTOMER DRAWING	-				
4 PLC ±							
ANGLES ±3°							
FINISH							
1							
2							

THIS DRAWING IS UNPUBLISHED. RELEASED FOR PUBLICATION .19  
 BY AMP INCORPORATED. ALL RIGHTS RESERVED.

LOC DY	DIST -	REVISIONS			DATE	DWN	APVD
P	LTR	DESCRIPTION					
		SEE SHEET 1 OF 2					

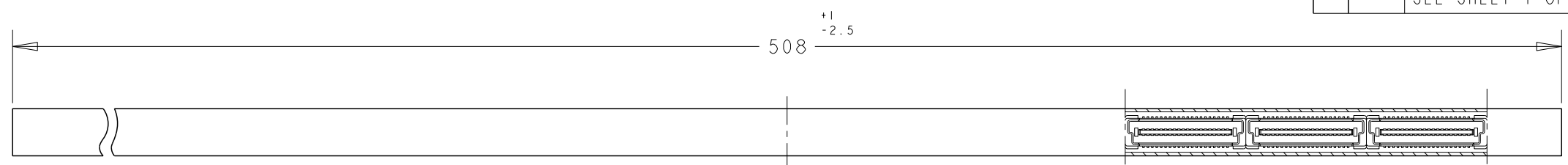

REFERENCE PICTURE OF TUBE PACK (WITHOUT STEEL COVER VERSION)



REFERENCE PICTURE OF TUBE PACK

PLUG ASS'Y (H=6mm), 0.8mm BTB STACKING CONN

SECT A-A

SECT B-B

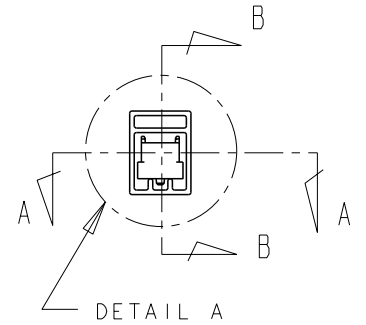

DETAIL A

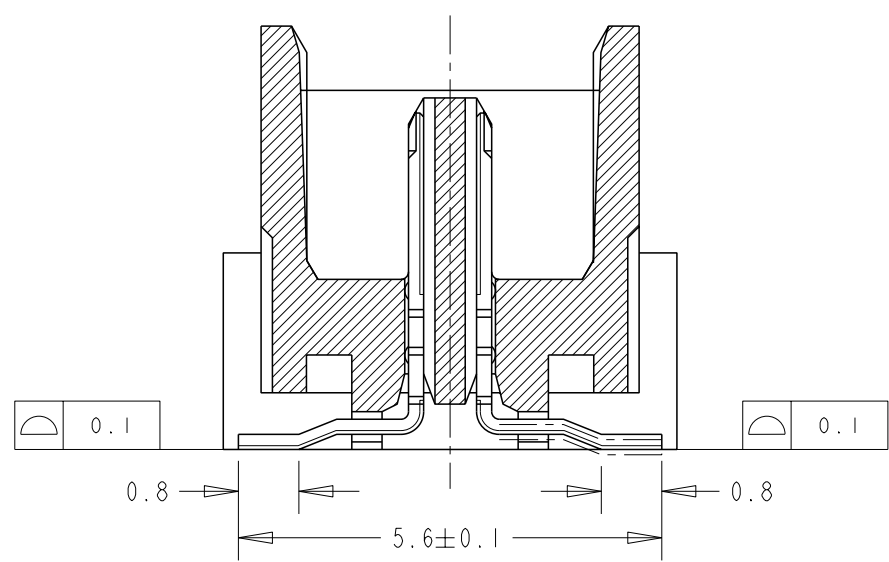

SECT. "A" - "A"

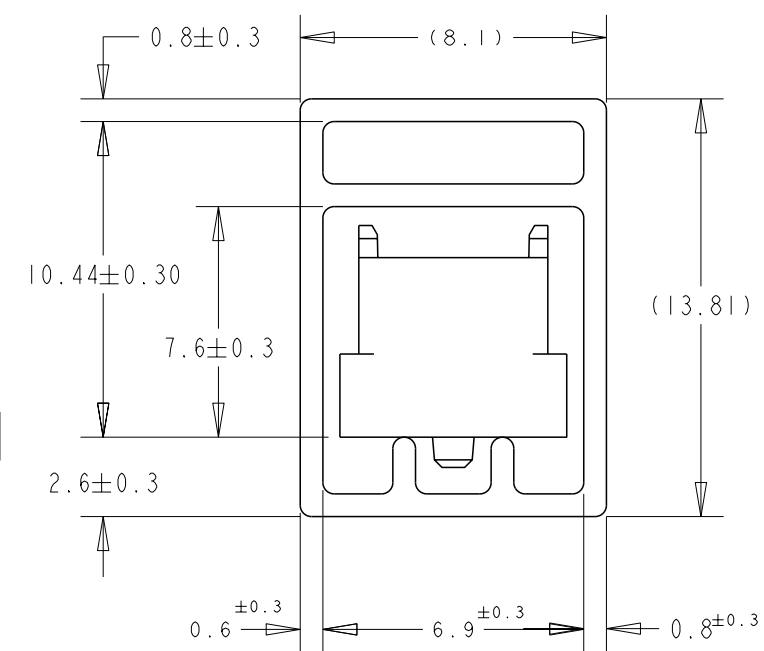

DETAIL "B"  
(SCALE 5-1)

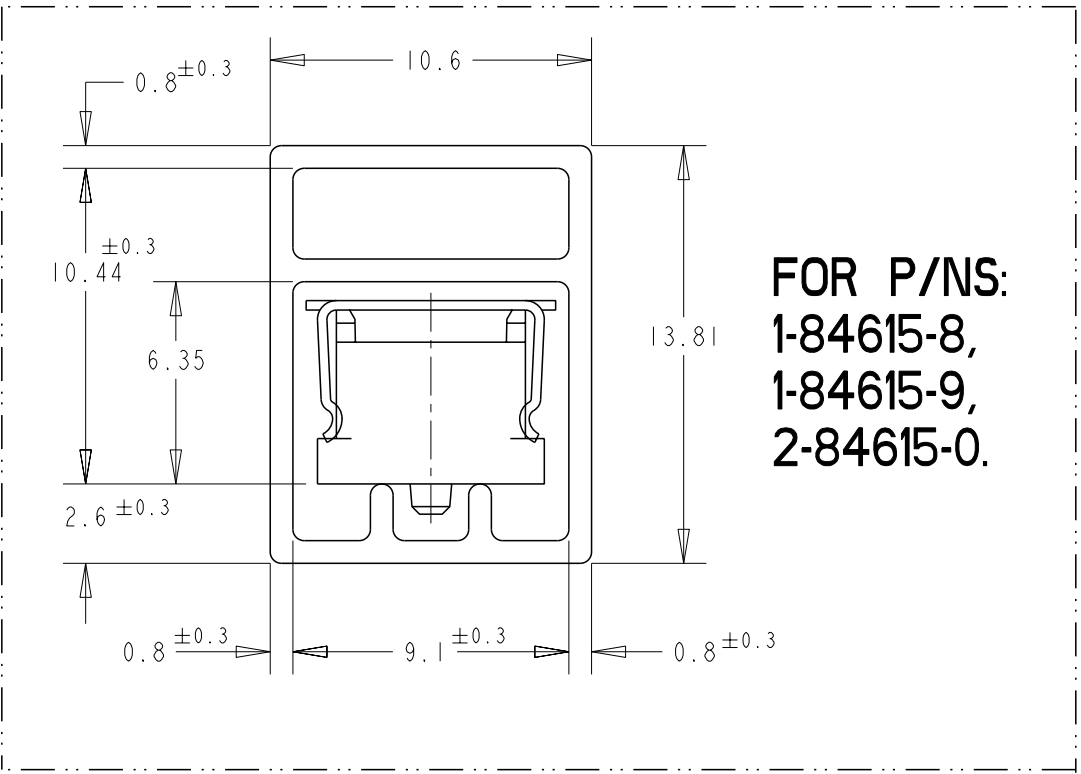

**FOR P/NS:  
1-84615-8,  
1-84615-9,  
2-84615-0.**

WITH STEEL COVER	AVAILABLE	5	84.2	85.8	79.2	200	2-	-0
		6	76.2	77.8	71.2	180	1-	-9
		6	68.2	69.8	63.2	160	1-	-8
		5	84.2	85.8	79.2	200	1-	-0
		6	76.2	77.8	71.2	180		-9
		6	68.2	69.8	63.2	160		-8
		7	60.2	61.8	55.2	140		-6
		9	52.2	53.8	47.2	120		-5
		10	44.2	45.8	39.2	100		-4
		12	36.2	37.8	31.2	80		-3
16	28.2	29.8	23.2	60		-2		
22	20.2	21.8	15.2	40		84615-1		
REMARKS	STATUS	QTY/ TUBE	C	B	A	POS.	CONN	P/N

THIS DRAWING IS A CONTROLLED DOCUMENT FOR AMP INCORPORATED. IT IS SUBJECT TO CHANGE AND THE CONTROLLING ENGINEERING ORGANIZATION SHOULD BE CONTACTED FOR THE LATEST REVISION.		DWN WYLEE	80CT98	<b>AMP</b>	AMP MANUFACTURING (SINGAPORE) PTE. LTD.		
DIMENSIONS: mm		CHK MARCUS	APVD ERIC ING		NAME PLUG ASSEMBLY 6H TYPE 30Au (0.5 BOSS LENGTH) FOR FH 0.8mm PITCH B-T-B CONNECTOR		
TOLERANCES UNLESS OTHERWISE SPECIFIED: 0 PLC ±- 1 PLC ±0.2 2 PLC ±0.25 3 PLC ±0.3 4 PLC ±- ANGLES ±3°		PRODUCT SPEC 108-5390	APPLICATION SPEC 114-5254	SIZE A3	CAGE CODE 00779	DRAWING NO C-84615	
MATERIAL 1	FINISH 2	WEIGHT -	CUSTOMER DRAWING	SCALE 4:1	SHEET 2 OF 2	REV F1	