

F

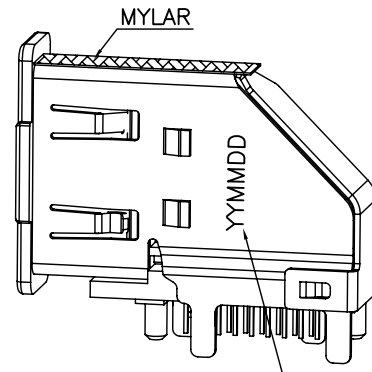
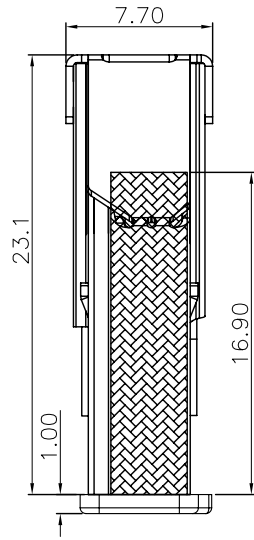

3D VIEW DATE CODE:YYMMDD

NOTES:

1. MATERIAL:
 - 1.1 SHELL: STAINLESS STEEL
 - 1.2 INSERT-MOLD HOUSING: THERMOPLASTIC UL 94V-0.
 - 1.3 CONTACT: COPPER ALLOY
2. PLATING:
 - TERMINAL:
 - CONTACT AREA:GOLD PLATING,DETAIL SEE TABLE
 - SOLDER AREA:2.54 MICRON MIN. TIN PLATING.
 - UNDERPLATE:1.27 MICRON MIN. NICKEL PLATING OVERALL.
 - SHELL:
 - 1.27 MICRON MIN. SOLDERABLE NICKEL PLATING OVERALL.
3. DATE CODE:YYMMDD. "YY" REPRESENTS YEAR, "MM" REPRESENTS MONTH,"DD" REPRESENTS DATE.
4. PRODUCT SPECIFICATION REFER TO PS-105089-001.
5. PACKAGE REFER TO PK-105089-001.
6. THE PRODUCT COMPLIANT TO RoHS DIRECTIVE 2002/95/EC AND ELV DIRECTIVE2000/53/EC.

E

F

E

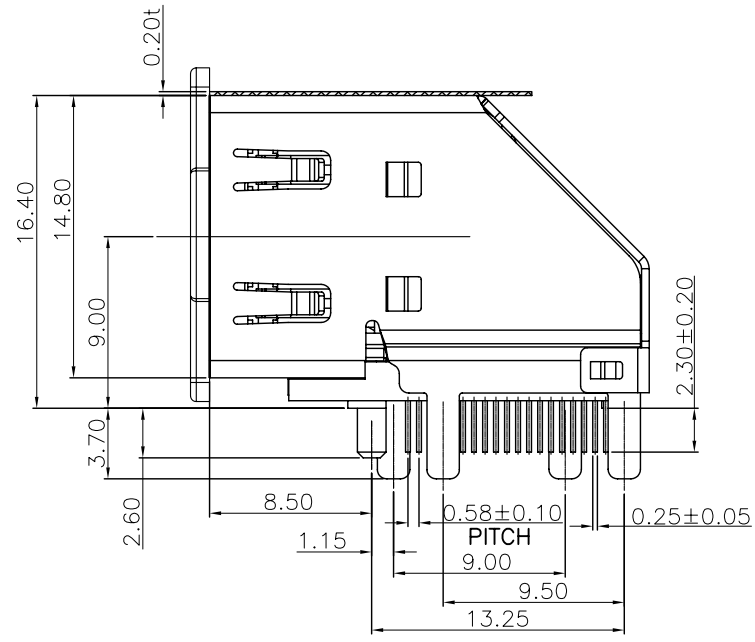
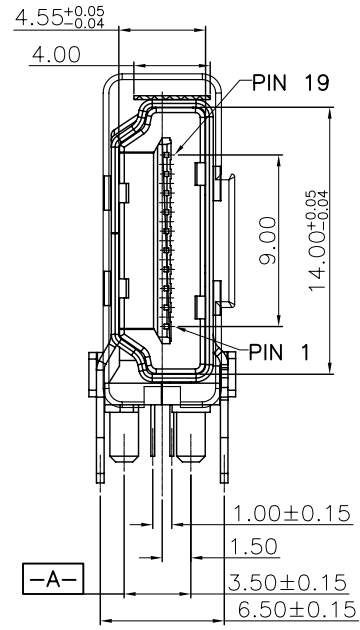

105089-1002	0.76MICRON MIN.GOLD PLATING
MOLEX P/N	CONATCT AREA PLATING

D

D

C

C

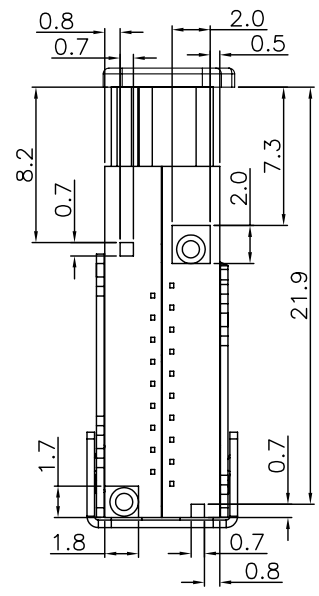
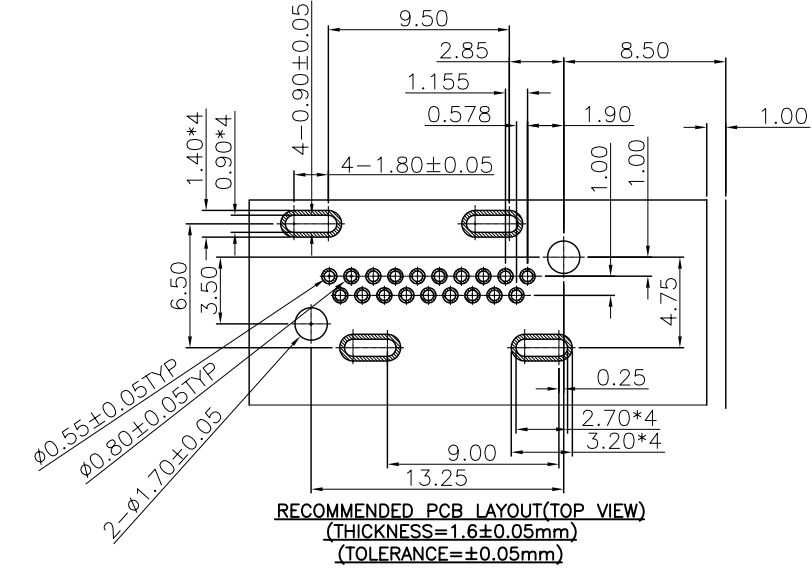

A

A

OBS part number EC NO:SH2013-0328 DRWN: Andy 2013/03/28 CHK'D: Daniel 2013/03/28 APPR: Daniel 2013/03/28	QUALITY SYMBOLS $F_A = 0$ $F_C = 0$ $F_P = 0$	GENERAL TOLERANCES (UNLESS SPECIFIED)		DIMENSION STYLE	SCALE	DESIGN UNITS	THIRD ANGLE PROJECTION	
			mm	INCH	MM ONLY	1:1		METRIC
		4 PLACES	± ---	± ---	DRAWN BY	DATE		TITLE
		3 PLACES	± ---	± ---	Andy	2012/02/13		HDMI UP-RIGHT RECEPTACLE CONNECTOR
			2 PLACES	± 0.10	± ---	CHECKED BY	DATE	
			1 PLACE	± 0.20	± ---	Daniel	2012/02/13	
			ANGULAR ± 1°		APPROVED BY	DATE		
			DRAFT WHERE APPLICABLE MUST REMAIN WITHIN DIMENSIONS		Daniel	2012/02/13		
					MATERIAL NO.	DOCUMENT NO.	SHEET NO.	
					REFERENCE TABLE	SD-105089-100	1 OF 1	
					SIZE	THIS DRAWING CONTAINS INFORMATION THAT IS PROPRIETARY TO MOLEX INCORPORATED AND SHOULD NOT BE USED WITHOUT WRITTEN PERMISSION		
					A3			