

Exclusive for headlight angle detection with high accuracy and space-saving design

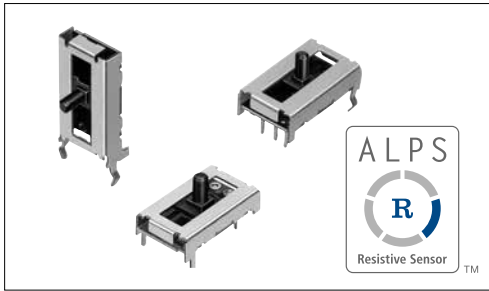

Typical Specifications



Items	Specifications
Rated Voltage	12V DC
Operating life	2N max.
Total resistance	100,000 cycles
Operating temperature range	-40°C to +105°C

Product Line

Travel (mm)	Mounting method	Total resistance (k Ω)	Linearity	Minimum order unit (pcs.)		Model No.	Drawing No.
				Japan	Export		
8	Vertical type	4.7	±1%	2,000	4,000	RD708A029A	1
	Horizontal type	5		1,500	3,000	RD7081015A	2
9				1,800	3,600	RD7091008A	3
12	Vertical type	2.2		2,000	4,000	RD712A028A	1
	Horizontal type	10		1,800	3,600	RD7121008A	4

Note

For linearity, various specifications will be available, depending on the applications. Please consult with us when placing your orders.

Packing Specifications





Tray





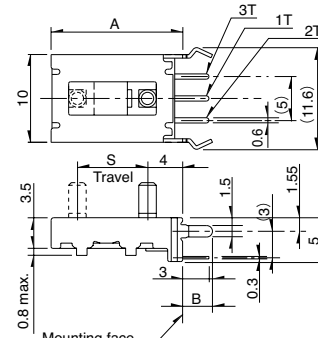
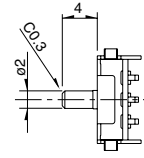
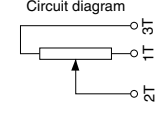

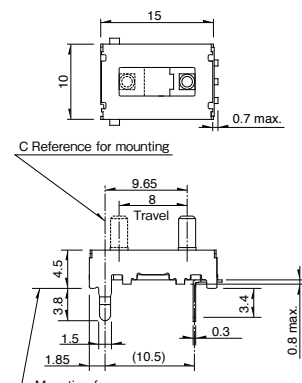
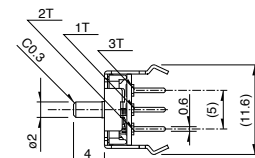
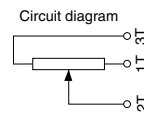

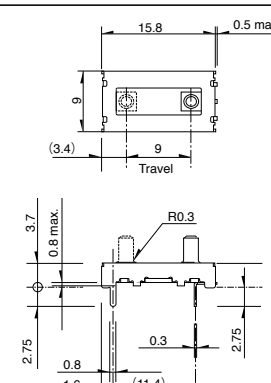
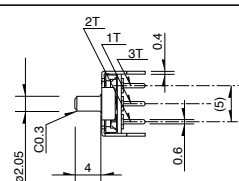
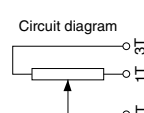
Model No.	Mounting method	Number of packages (pcs.)		Export package measurements (mm)
		1 case /Japan	1 case /export packing	
RD708	Vertical	2,000	4,000	527×363×215
	Horizontal	1,500	3,000	507×363×216
RD709		1,800	3,600	508×364×192
RD712	Vertical	2,000	4,000	527×363×118
	Horizontal	1,800	3,600	507×363×216

Refer to P.466 for product specifications.
Refer to P.467 for soldering conditions.

Dimensions

Unit:mm

No.	Photo	Style												
1	<p>RD708A RD712A</p> 	  <table border="1" data-bbox="1085 582 1404 705"> <thead> <tr> <th>Dimension Model</th> <th>S</th> <th>A</th> <th>B</th> </tr> </thead> <tbody> <tr> <td>RD708A</td> <td>8</td> <td>15</td> <td>3.4</td> </tr> <tr> <td>RD712A</td> <td>12</td> <td>19</td> <td>3.8</td> </tr> </tbody> </table>	Dimension Model	S	A	B	RD708A	8	15	3.4	RD712A	12	19	3.8
Dimension Model	S	A	B											
RD708A	8	15	3.4											
RD712A	12	19	3.8											
2	<p>RD7081</p> 	 												
3	<p>RD7091</p> 	 												
4	<p>RD7121</p> 	 												

Type	Magnetic Rotary Type	Linear Type			
Series	RDCC0	RDC1010	RDC10	※ RD7	
Photo					
Direction of lever	Vertical			Vertical Horizontal	
Effective electrical angle (°)	30	—	—	—	
Linearity guarantee range (°)	±15	—	—	—	
Travel	—	10mm	14mm 22mm 32mm 47mm	8mm 12mm 8mm 9mm 12mm	
Operating temperature range	0°C to +50°C	-30°C to +85°C		-40°C to +105°C	
Operating life	10,000,000 cycles	50,000 cycles	200,000 cycles	100,000 cycles	
Available for automotive use	—	—	●	●	
Life cycle (availability)					
Mechanical performance	Operating force	—	0.25N max.		
	Rotational torque	5mN·m max.	—	—	
Electrical performance	Total resistance tolerance	—	±30%		
	Linearity (%)	±2	±0.5		
	Rated voltage (V DC)	5			12
Environmental performance	Cold	-40°C 240h			-40°C 96h
	Dry heat	85°C 240h	80°C 240h	90°C 240h	105°C 96h
	Damp heat	60°C, 90 to 95%RH 240h			40°C, 90 to 95%RH 96h
Terminal style	Connector	Insertion	Lead terminal/Insertion	Insertion	
Page	460	461		464	

Resistive Position Sensors Measurement and Test Methods	466
Resistive Position Sensors Soldering Conditions	467
Resistive Position Sensors Cautions	468

Notes

1. ※ The RD7 series are used to detect vehicle headlight angles.
2. ● Indicates applicability to all products in the series.

Method for Regulating the Linearity

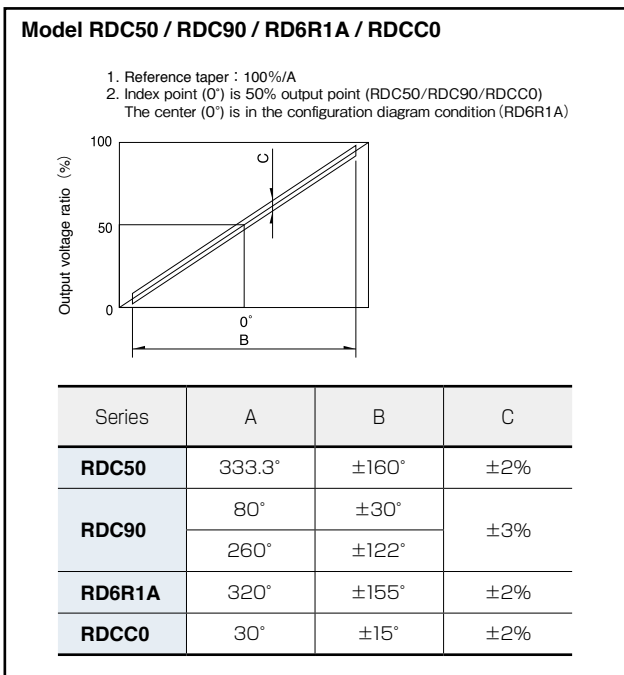
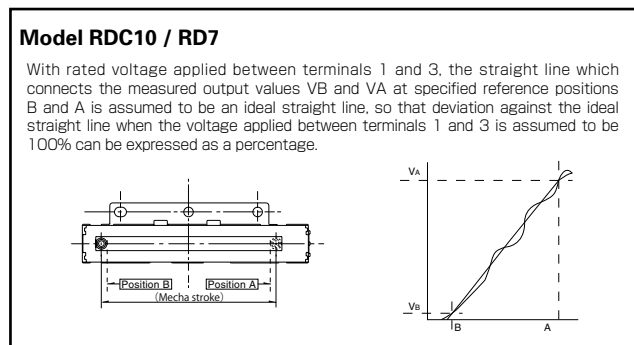
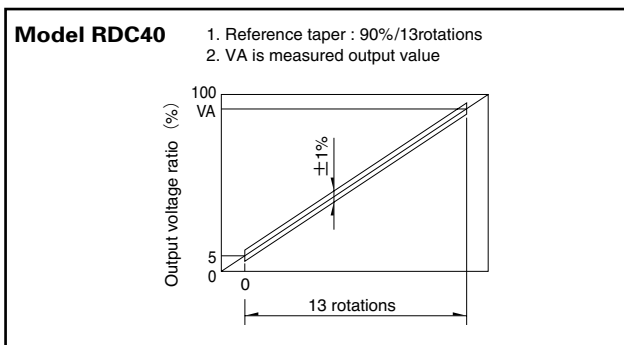

Resistive Position Sensors / Measurement and Test Methods

Resistive Position Sensor

[Total Resistance]

The total resistance, with the shaft (lever) placed at the end of terminal 1 or 3, shall be determined by measuring the resistance between the resistor terminals 1 and 3 unless otherwise specified.

[Rating Voltage]

The rating voltage corresponding to the rated power shall be determined by the following equation. When the resulting rated voltage exceeds the maximum operating voltage of a specific resistor, the maximum operating voltage shall be taken as the rated voltage.

$$E = \sqrt{P \cdot R}$$

E : Rated voltage (V)
P : Rated power (W)
R : Total nominal resistance (Ω)

Reference for Manual Soldering

Series	Tip temperature	Soldering time
RDC50, RDC90	350±5°C	3 ⁺ ₀ s
RDC10, RD7	350°C max.	3s max.

Reference for Dip Soldering

Series	Preheating		Dip soldering		No. of solders
	Soldering surface temperature	Heating time	Soldering temperature	Soldering time	
RDC501, RDC502	100 to 150°C	1minute max.	260±5°C	10±1s	1 time
RD7	100°C max.	1minute max.	260°C max.	5s max.	1 time

Example of Reflow Soldering Condition

- Cleaning sensors should not be attempted.
- Type of solder to be used Use cream solder that contains 10 to 15 %wt flux.
- Number of solder applications - apply solder only once
- Recommended reflow conditions

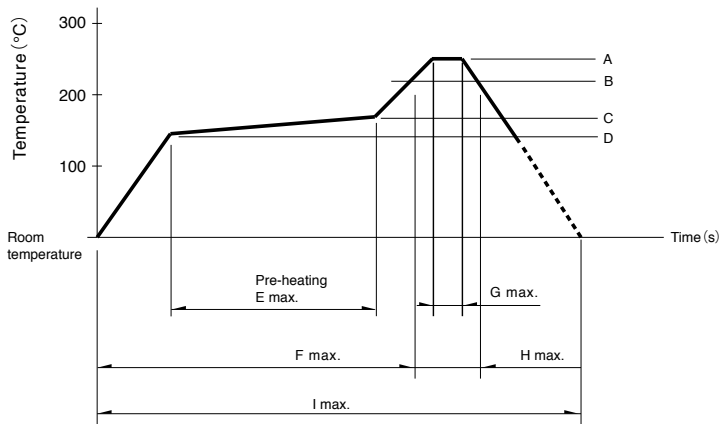

Series	A	B	C	D	E	F	G	H	I	No. of reflows
RDC503 RDC506	250°C	230°C	180°C	150°C	2min.	—	5s	40s	4min.	1 time
RDC90	255°C	230°C	—	—	—	2min.	10s	1min.	4min.	1 time

Notes

- When using an infrared reflow oven, solder may not always be applied as intended. Be sure to use a hot air reflow oven or a type that uses infrared rays in combination with hot air.
- The temperatures given above are the maximum temperatures at the terminals of the sensor when employing a hot air reflow method. The temperature of the PC board and the surface temperature of the sensor may vary greatly depending on the PC board material, its size and thickness. Ensure that the surface temperature of the sensor does not rise to 250°C or greater.
- Conditions vary to some extent depending on the type of reflow bath used. Be sure to give due consideration to this prior to use.