

Customer Part Number: *not provided*



Fox Part Number: 845-12.8-1

**25.4 x 22.1mm, OVEN-CONTROLLED, HCMOS, SMD, OSCILLATOR
MODEL: FTM301AH Series**

RoHS / REACH Compliant / Pb Free

Specifications

PARAMETERS	SPECIFICATION
Frequency (F _O)	12.800000 MHz
Frequency Stability vs.:	
Operating Temperature (T _{OPR})	±10 ppb (0.010ppm)
Change of V _{DD} (±5%)	±0.5 ppb (0.0005ppm)
Temperature Range:	
Operating (T _{OPR})	-40°C ~ +85°C
Storage (T _{STG})	-40°C ~ +85°C
Supply Voltage (V _{DD})	3.3V _{DC} ±5%
Output Load (HCMOS)	15 pF ±1 pF
Output Voltage	
(V _{OL})	0.1V Typ, 0.4V Max
(V _{OH})	3.3V Typ, 2.8V Min
Spurious	-60dBc Max
Rise Time (T _R) (10% ~ 90% V _{DD})	5 nS Max
Fall Time (T _F) (90% ~ 10% V _{DD})	5 nS Max
Symmetry	45% / 55%
Frequency Control	
Slope	Positive
Pin #2 Reference (V _{REF} into 9k Min)	2.8 ±0.1V _{DC}
Frequency Change (ΔF)	±0.5 ppm Min.
Non-Linearity (0.8V to V _{DD})	±10 %
Voltage Control (V _C)	0V to 2.8V
Input Impedance (Z _{IN})	100K Ohm Min.
Warm Up:	
Time (to ±10 ppb)	5 Minutes
(Referenced to F _O @ 60min after turn-on)	
Warm-Up Current	1000mA Max
Operating Power	1.2 W Max at 25°C
Aging:	
Short-term Aging (1 st 45 days)	±0.5 ppb / day Max
1 st year Aging (after 45 days)	±50 ppb
Long Term (10-years ALL effects)	±0.4 ppm Max
Allan Variance (1 sec samples)	<50 x 10 ⁻¹² / Sec
Phase Noise:	
@ 1 Hz Offset:	-95 dBc/Hz Typ
@ 10 Hz Offset:	-120 dBc/Hz Typ
@ 100 Hz Offset:	-135 dBc/Hz Typ
@ 1 kHz Offset:	-145 dBc/Hz Typ
@ 10 kHz Offset:	-155 dBc/Hz Typ
Moisture Sensitivity Level (MSL)	1
Termination Finish	Immersion Gold
Weight (Typ)	5.7 g

Mechanical / Dimensions (millimeters):

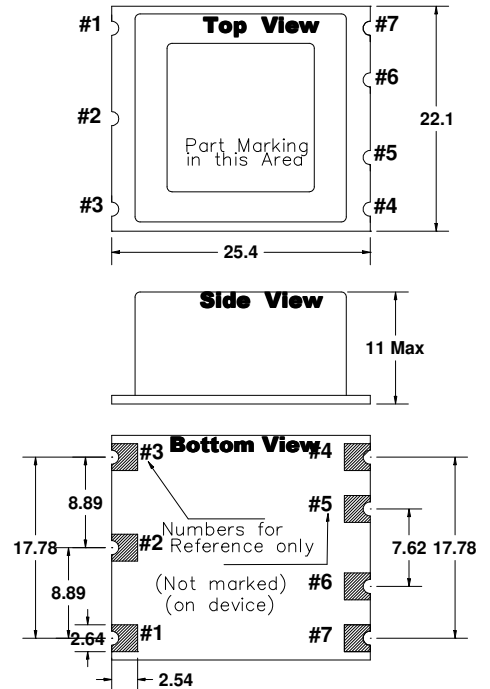

Recommended Solder Pad Layout

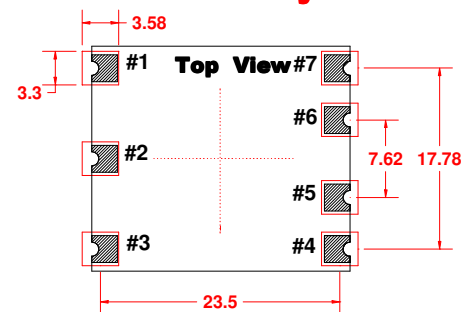

Pin Connections

- #1 V_C
 - #2 V_{REF}
 - #3 V_{DD}
 - #4 RF Output
 - #5 No Connect
 - #6 No Connect
 - #7 GND / Case
- Metal Cover: Nickel-Silver

Recommended V_C Adjustment circuit

Reference / Comments	Title / Description: Product Description Specifications		
Initial release	Drawing Number: DWG-8912	Rev: 1	Size: A
	Part Number: 845-12.8-1		Cage: 61429
	Draftsperson: GB	Approved: AR	Date: 09-10-2014

Customer Part Number: *not provided*



Fox Part Number: 845-12.8-1

25.4 x 22.1mm, OVEN-CONTROLLED, HCMOS, SMD, OSCILLATOR
MODEL: FTM301AH Series

RoHS / REACH Compliant / Pb Free

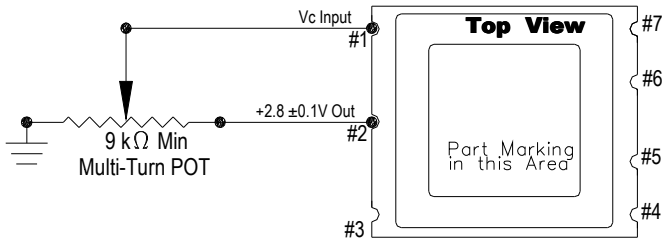

Tape & Reel Specifications
150 pieces per Reel

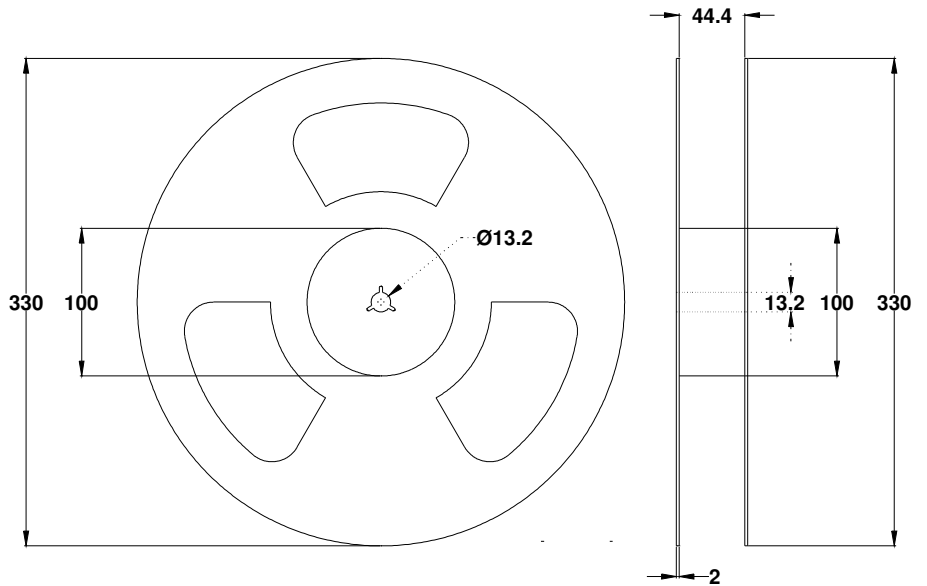
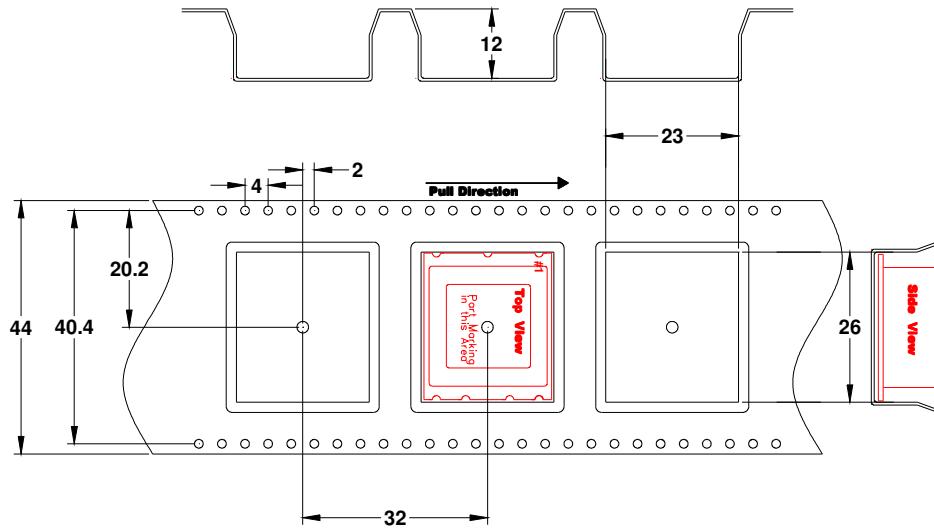

Reference / Comments	Title / Description: Product Description Specifications		
	Drawing Number: DWG-8912	Rev: 1	Size: A
	Part Number: 845-12.8-1		Cage: 61429
	Draftsperson: GB	Approved: AR	Date: 09-10-2014