

Introduction

Exar's XR32220 EVB evaluation board provides a platform on which to examine the features and performance of the XR32220 2-Driver/2-Receiver RS-232 serial transceiver. The XR32220_EVB is a 2 layer pcb that allows for access to all the device pins.

Hardware Setup

To use the Evaluation Board, the following components are required:

1. XR32220 EVB evaluation board
2. Power supply
3. Signal source
4. Oscilloscope for data analysis
5. Digital Multimeter

Refer to the product data sheet for additional information.

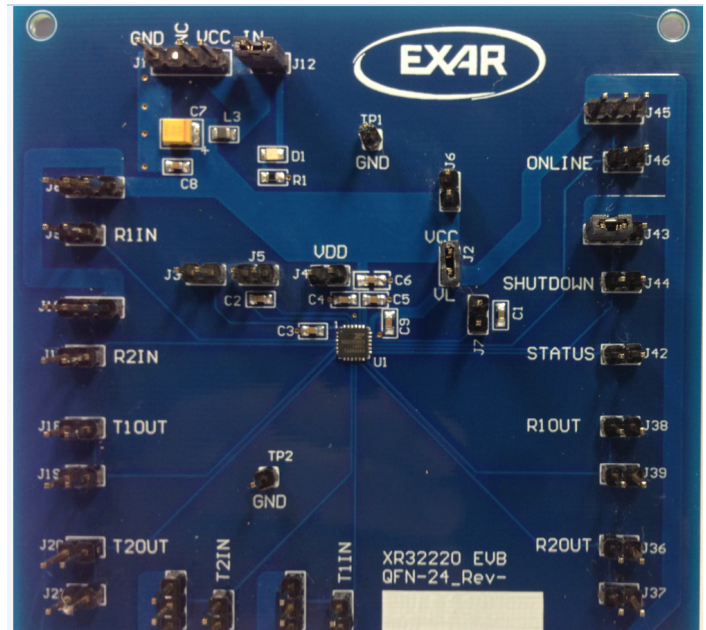

Figure 1: Top View of XR32220-EVB

Evaluation Board Overview

The block diagram shown in Figure 2, illustrates the connection points for the RS232 receivers, RS232 drivers, power and ground, TTL/CMOS driver inputs, TTL/CMOS receiver outputs and the control and status pins.

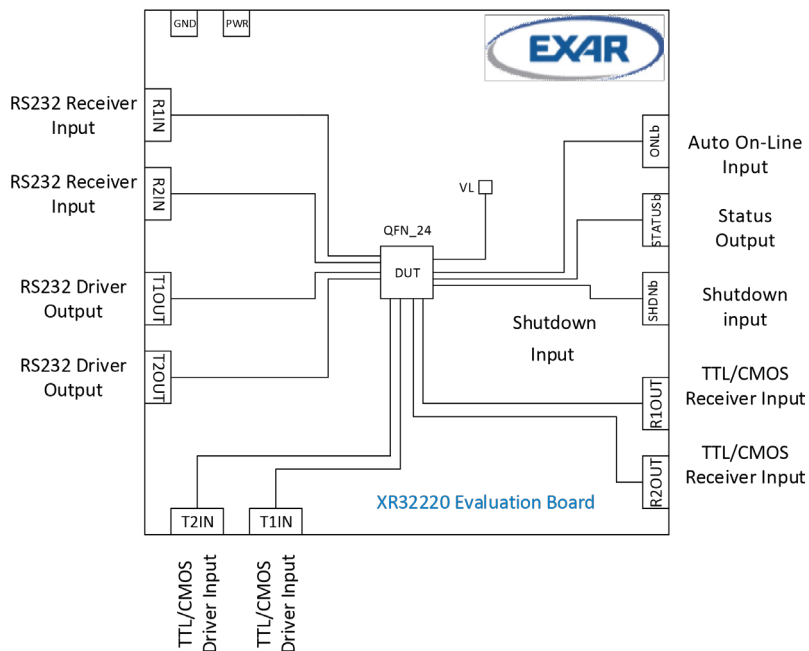

Figure 2: Block Diagram XR32220-EVB

Hardware / System Setup

Jumpers are factory installed per Table 1. Jumper and testing options are described in the next section.

Header	Factory Setting	Description
J2	Jumper 1-2	Connects VL to VCC

Table 1: Factory Settings

Connect J43 and J45 per Table 2 to configure the EVB for normal mode operation.

Header	Configuration	Description
J43	Jumper 2-3	Shutdown = 1 enables normal mode
J45	Jumper 2-3	Online = 1 enables normal mode

Table 2: Normal Mode Configuration

Connect the RS232 drivers and receivers, TTL/CMOS Driver Inputs and Receiver Outputs per Table 3 and power and ground per Table 4 for immediate evaluation of the XR32220 functionality and performance.

Header	Connection	Pin
J9	RS232 receiver input	R1IN
J11	RS232 receiver input	R2IN
J19	RS232 driver output	T1OUT
J21	RS232 driver output	T2OUT
J29	TTL / CMOS driver input	T1IN
J27	TTL / CMOS driver input	T2IN
J39	TTL / CMOS receiver output	R1OUT
J37	TTL / CMOS receiver output	R2OUT

Table 3: Input and Output Connections

J1	J1-1	J1-2	J1-3	J1-4
Name	GND	NC	VCC	VCC

NOTE:

1. V_{CC} = 3.0V to 5.5V

Table 4: Power and Ground Connections

Pin J1-1 is the ground connection to the XR32220 evaluation board and is a common ground connection to the entire board. An external 3.3V ±10% or 5.0V ±10% supply, referenced to J1 pin 1 ground, should be connect to J1 pins 3 & 4.

Use probes summarized in Table 5 to observe operation at various points. TP1 and TP2 provide GND for probes at 2 different spots.

Header	Probe Points
J3, J4, J5, J7	C3, C4, C2 and C1 charge pump capacitors
J6	V _{CC} into XR32220 transceiver
J42	Status output

Table 5: Monitoring Probes

Jumper and Testing Options

TTL / CMOS Logic Supply, VL - J2

The XR32220 has a separate logic supply pin, VL, which controls the logic levels for the following pins: T1IN, T2IN, R1OUT, R2OUT, Shutdown, Online and Status.

With a jumper placed across J2 the logic supply is tied to VCC. To drive the VL logic supply to a lower voltage than VCC, simply remove the jumper across J2 and connect the separate external logic supply to pin 2 of J2. The logic supply voltage, VL, must always be less than or equal to VCC.

Power LED - J12

Connect Jumper J12 1-2 to illuminate the D1 LED when power is connected if desired.

RS232 Receiver Inputs - J9 and J11 (J8 and J10)

Pin 2 on both the J9 and J11 connectors is the RS232 receiver input and pin 1 is ground. There is a 3 pin jumper next to each of the test points, J8 and J10, to allow the receiver inputs to be tied to VCC or ground if desired. Normally the RS232 signal is applied to Pin 2 of J9 and J11 and J8 and J10 are unused.

RS232 Driver Outputs - J19 and J21 (J18 and J20)

Pin 2 on both the J19 and J21 connectors is the RS232 driver output and pin 1 is ground. There is a 2 pin jumper next to each of these test points, J18 and J20, to allow for any external loads to be applied if desired.

TTL/CMOS Driver Inputs - J27 and J29 (J26 and J28)

Pin 2 on both the J27 and J29 connectors is the TTL/CMOS driver input and pin 1 is ground. There is a 3 pin jumper next to each of the test points, J28 and J26 to allow the driver inputs to be tied to VL or ground if desired. Normally the signal generator would be applied to Pin 2 of J29 and/or J27 and J28 and J26 would not be used.

TTL/CMOS Receiver Outputs - J37 and J39 (J36 and J38)

Pin 2 on both connectors is the TTL/CMOS receiver output and pin 1 is ground. There is a 2 pin jumper next to each of these test points, J38 and J36, to allow for any external loads to be applied if desired.

Control and Status Connections - J42, J44, and J46

The test points for Shutdown & Online (Auto On-Line) are jumpers J44 and J46 respectively. These TTL/CMOS inputs accept VL supply logic levels. Pin 2 on both connectors is the input and pin 1 is ground. There is a 3 pin jumper next to each of the test points, J45 and J43 to allow the control inputs to be tied to VL or ground if desired.

J42 is connected to the Status pin for easy probing.

Paddle connection - R2

The XR32220 24pin QFN package has a paddle on the underside. It is recommended that the paddle be connected to ground on the PCB. The schematic of the evaluation board pcb below shows this connection to ground. If it is desired to remove the connection to ground, simply remove R2.

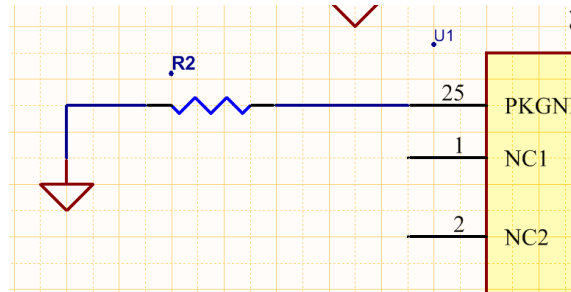

Figure 3: XR32220 paddle connection to ground

Pin Configuration

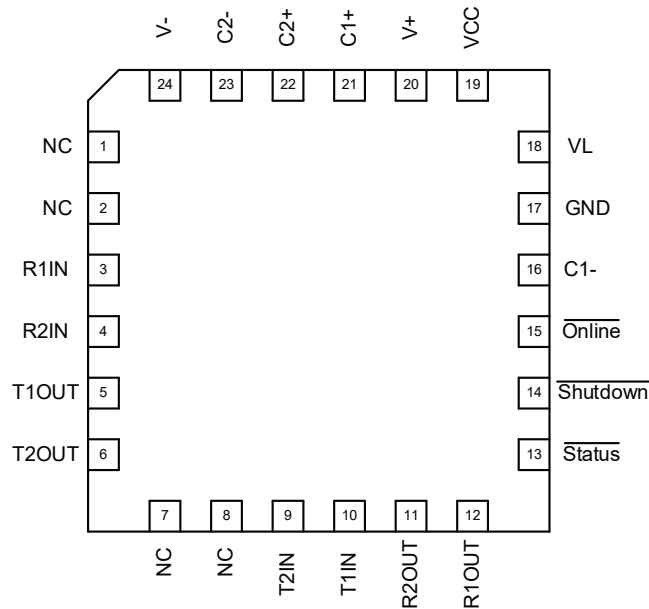

Figure 4: XR32220 Pin Configuration

XR32220 EVB Schematic

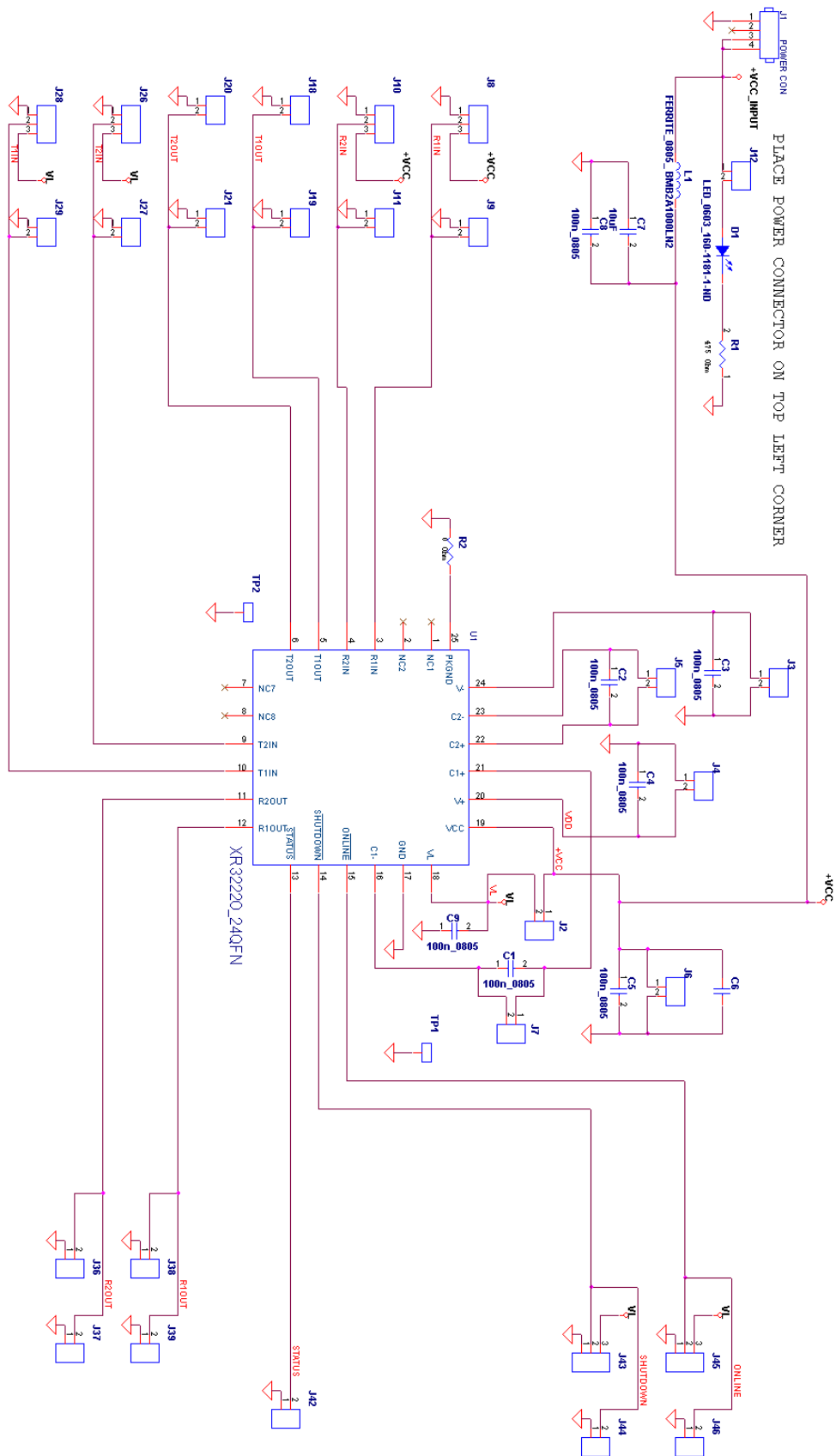

Figure 5: XR32220-EVB Schematic

XR32220 EVB Bill of Material

Item	Quantity	Reference	Part
1	7	C1, C2, C3, C4, C5, C8, C9	100nF_0805
2	1	C6	1uF_0805
3	1	C7	10uF_1210
4	1	D1	LED_160-1181-1-ND_0603
5	22	J2, J3, J4, J5, J6, J7, J9, J11, J12, J18, J19, J20, J21, J27, J29, J36, J37, J38, J39, J42, J44, J46	Header 2
6	6	J8, J10, J26, J28, J43, J45	Header 3
7	1	J1	Header 4
8	1	L3	Inductor_BMB2A1000LN2_0805
9	1	R1	475ohm_0805
10	1	R2	0ohm_0805
11	2	TP1, TP2	Test point
12	1	U1	XR32220 Sample

Table 4: Evaluation Board Bill of Material (BOM)

Power Supply Recommendations

In order to ensure reliable operation at all data rates and supply voltages, each supply should have at least 100nF ceramic capacitor located as close to the supply terminals (VL or Vcc) as possible. Additional 10uF and 100nF (C5 and C6) are recommended if the supply source is generated from a linear power supply/regulator.

Layout Recommendations

1. Apply at least 100nF bypass capacitors as close as possible to Vcc terminal and VL terminal of transceiver.
2. Use at least two vias for Vcc/VL and GROUND connections of bypass capacitors to minimize effective via-inductance.
3. When possible, use Vcc and GROUND plane to provide low-inductance traces and signal path.



Corporate Headquarters:

5966 La Place Court
Suite 100
Carlsbad, CA 92008
Tel.: +1 (760) 692-0711
Fax: +1 (760) 444-8598
www.maxlinear.com

High Performance Analog:

1060 Rincon Circle
San Jose, CA 95131
Tel.: +1 (669) 265-6100
Fax: +1 (669) 265-6101
Email: serialtechsupport@exar.com
www.exar.com

The content of this document is furnished for informational use only, is subject to change without notice, and should not be construed as a commitment by MaxLinear, Inc.. MaxLinear, Inc. assumes no responsibility or liability for any errors or inaccuracies that may appear in the informational content contained in this guide. Complying with all applicable copyright laws is the responsibility of the user. Without limiting the rights under copyright, no part of this document may be reproduced into, stored in, or introduced into a retrieval system, or transmitted in any form or by any means (electronic, mechanical, photocopying, recording, or otherwise), or for any purpose, without the express written permission of MaxLinear, Inc.

MaxLinear, Inc. does not recommend the use of any of its products in life support applications where the failure or malfunction of the product can reasonably be expected to cause failure of the life support system or to significantly affect its safety or effectiveness. Products are not authorized for use in such applications unless MaxLinear, Inc. receives, in writing, assurances to its satisfaction that: (a) the risk of injury or damage has been minimized; (b) the user assumes all such risks; (c) potential liability of

MaxLinear, Inc. is adequately protected under the circumstances.

MaxLinear, Inc. may have patents, patent applications, trademarks, copyrights, or other intellectual property rights covering subject matter in this document. Except as expressly provided in any written license agreement from MaxLinear, Inc., the furnishing of this document does not give you any license to these patents, trademarks, copyrights, or other intellectual property.

Company and product names may be registered trademarks or trademarks of the respective owners with which they are associated.

© 2017 MaxLinear, Inc. All rights reserved