

PRODUCT NUMBER
SEE TABLE, SHT 3

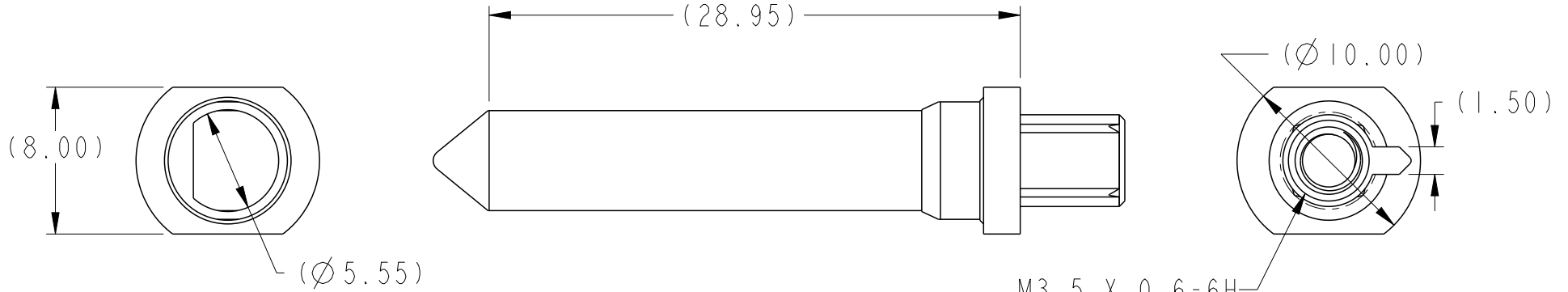
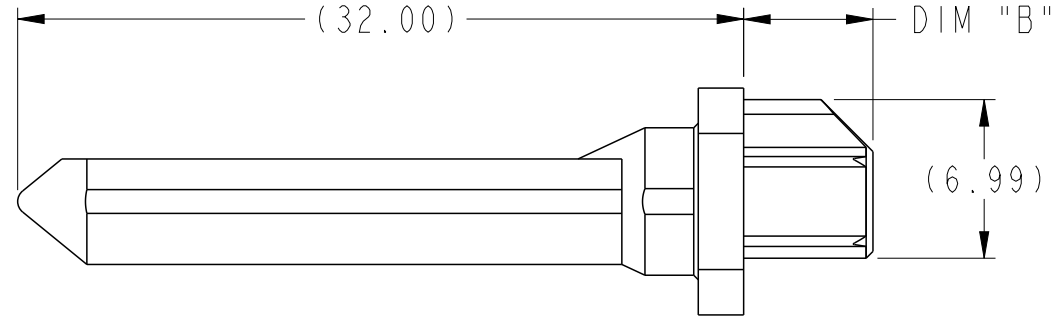

M3.5 X 0.6-6H
SEE TABLE DIM "D"
△H FOR MIN THREAD DEPTH

spec ref		-		dr	Chen-Hong Tan	2005/08/18	projection 	MM ←→	size	A4	scale	3:1
tolerance std	ASME Y14.5	TOLERANCES UNLESS OTHERWISE SPECIFIED		eng	N Anandakumar	2016/12/02			ecn no	ELX-S-25501-1		
				chr	-	-				rel level	Released	
surface	3.200	linear	0.X	±0.3	Amphenol FCi	title	10.8mm GUIDE PIN, INTERNAL THREAD	dwg no	10037911		rev	H
		angular	0°	±2°					cat. no.	-	Product - Customer Drw	sheet 1 of 3

10.8 MM RECEPTACLE GUIDE MODULE NOTE 4	DIM "A"
10037912-1X1LF	0°
10037912-1X2LF	45°
10037912-1X3LF	90°
10037912-1X4LF	135°
10037912-1X5LF	180°
10037912-1X6LF	225°
10037912-1X7LF	270°
10037912-1X8LF	315°

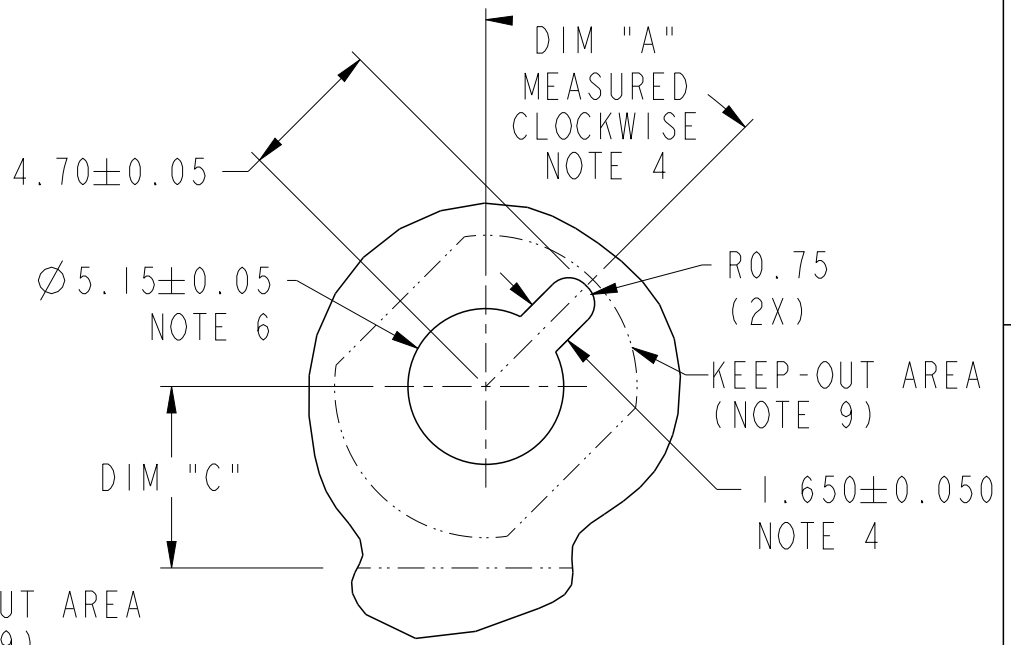
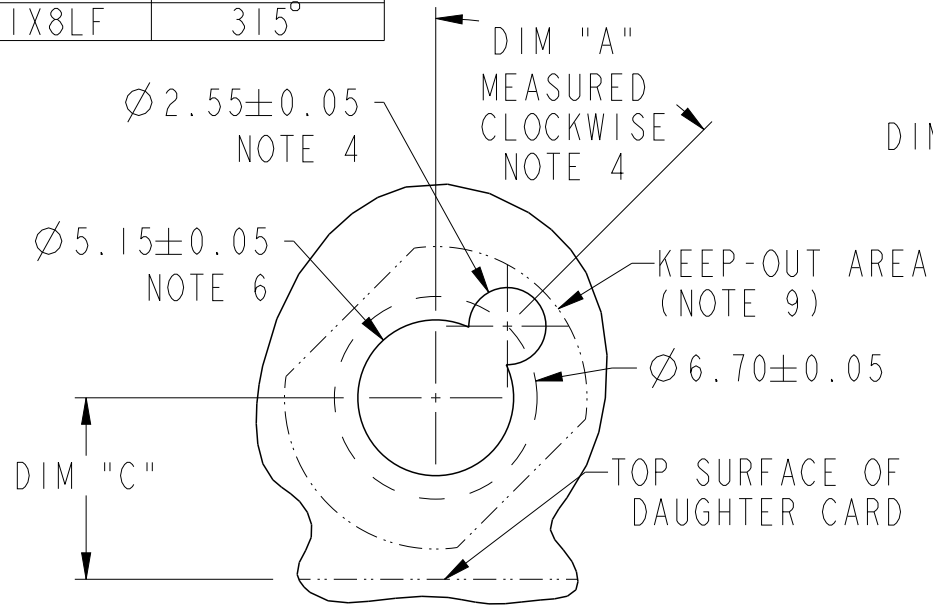

Amphenol
FCi

© 2016 AFci

spec ref	-	dr	Chen-Hong Tan	2005/08/18	projection	MM	size	A4	scale	1:1	
tolerance std	ASME Y14.5	eng	N Anandakumar	2016/12/02			ecn no	ELX-S-25501-1			
TOLERANCES UNLESS OTHERWISE SPECIFIED		chr	-	-			rel level	Released			
surface	linear	appr	Chen-Hong Tan	2016/12/12	product family	-	rel level	Released			
ASME Y14.5	✓	0.X	±0.3	Amphenol FCi	title	10.8mm GUIDE PIN, INTERNAL THREAD	dwg no	10037911		rev	H
		0.XX	±0.10					cat. no.	-	Product - Customer Drw	sheet 2 of 3
		0.XXX	±0.05								
angular	0°	±2°									

Creo File - REV E - 2016-02-12

A

B

C

D

PRODUCT NUMBER	DIM "B"	DIM "C" 4/5 PAIR	DIM "C" 2/3 PAIR	DIM "D"
10037911-101LF	5.70	6.00	4.50	6.60
10037911-102LF	2.75	6.00	4.50	4.10
10037911-103LF	3.20	6.00	4.50	4.10
10037911-104LF	2.40	6.00	4.50	4.10

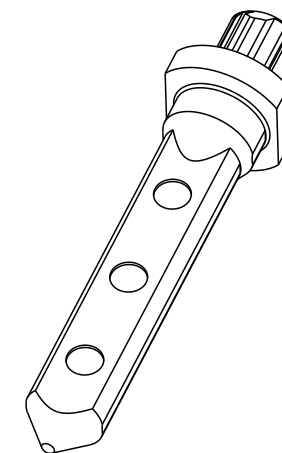

1. MATERIAL: ZINC ALLOY
2. FINISH: ZINC YELLOW CHROMATE
3. APPLICATION SPECIFICATION: GS-20-045
- ④ KEY HOLE ORIENTATION (DIM "A") WILL BE DEFINED BY THE MATING RECEPTACLE GUIDE MODULE PART NUMBER - SEE TABLE (ORIENTATION SHOWN IS FOR 10037912-1X2LF)
- ⑤ REFER TO CUSTOMER DRAWING 10035911 FOR INFORMATION REGARDING PCB LAYOUT OF POWER AND GUIDE MODULES RELATIVE TO SIGNAL MODULES
- ⑥ THRU HOLE PLATING AND ANNULAR RINGS MUST BE ADDED IN APPLICATIONS THAT USE THE ESD GROUNDING OPTION FINISHED HOLE SIZE IS THE SAME REGARDLESS OF PLATED BARREL OR NOT.
7. THIS PRODUCT MEETS EUROPEAN UNION DIRECTIVES AND OTHER COUNTRY REGULATIONS AS DESCRIBED IN GS-22-008.
8. PACKAGING MEETS GS-14-920 LEAD FREE LABELING SPECIFICATION.
- ⑨ KEEP OUT ZONE MATCH PROFILE OF SEATED GUIDE PIN, SEE SHEET 1 FOR REFERENCE DIMENSIONS OF GUIDE PIN OUTLINE.
10. A SYMBOL WILL BE NEXT TO ANY DIMENSION, VIEW OR NOTE WHICH HAS BEEN MODIFIED WITH THE CURRENT DRAWING REVISION.

spec ref		-		dr	Chen-Hong Tan	2005/08/18	projection	MM	size	A4	scale	3:1				
tolerance std	ASME Y14.5	TOLERANCES UNLESS OTHERWISE SPECIFIED		eng	N Anandakumar	2016/12/02					ecn no			ELX-S-25501-1		
				chr	-	-					rel level			Released		
surface		3.200		appr	Chen-Hong Tan	2016/12/12	product family			AirMax Accessories	rev					
ASME Y14.5	linear	0.X	±0.3	Amphenol FCi			title			10.8mm GUIDE PIN, INTERNAL THREAD		dwg no	10037911		rev	H
		0.XX	±0.10													
0.XXX	±0.05															
angular		0°	±2°	cat. no.			-	Product - Customer Drw			sheet 3 of 3					