

## Relay I/O Block

G7TC

Reduces Wiring within the Control Panel and Reduces Installation Time

- Compact 16-pt models: 182 W × 85 D × 68 H mm; 8-pt block width is 102 mm
- Can be connected to the PLC with a connecting cable and a snap-in connector
- Equipped with surge suppressor circuit and LED indicators
- Mounts easily on a DIN rail

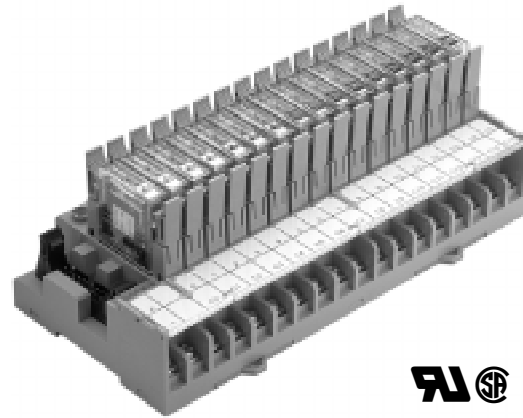

## Ordering Information

### ■ G7TC RELAY I/O BLOCKS

Relay I/O Blocks include the I/O Base with G7T Relays installed.

I/O classification	I/O points	Internal I/O circuit common	Rated coil voltage	Part number
Input	16	NPN (⊖ common)	24 VDC	G7TC-ID16 DC24V
				G7TC-ID16-5 DC24V (See Note 1)
		NPN (⊖ common)	110/120 VAC	G7TC-IA16 AC110/120V
			220/240 VAC	G7TC-IA16-5 AC100/110V (See Note 1) G7TC-IA16 AC220/240V
Output (See Note 2)	16	NPN (⊕ common)	12 VDC	G7TC-OC16 DC12V
			24 VDC	G7TC-OC16 DC24V
		PNP (⊖ common)	24 VDC	G7TC-OC16-1 DC24V
	8	NPN (⊕ common)	12 VDC	G7TC-OC08 DC12V
			24 VDC	G7TC-OC08 DC24V
		PNP (⊖ common)	24 VDC	G7TC-OC08-1 DC24V

- Note: 1. The “-5” Block is for use with DRT1-ID16X DeviceNet Remote Adapter.  
 2. Output relays are rated up to 250 VAC. See “Specifications” for specific relay ratings.

### ■ P7TF BLOCK BASES AND RELAYS

Combine Relays and P7TF Block Bases to match your application requirements. Use the table below to configure Relay Blocks.

I/O points	Internal I/O circuit	Part number				
		Block Base	I/O Relay		Solid State Relay	
16 inputs (AC coil)	NPN (- common)	P7TF-IS16 AC110/120V	1 A	G7T-1122S AC110/120 or G7T-1122S AC200/220V	25 mA	G3TA-IAZR02S AC100/240V
16 inputs (DC coil)	NPN (- common)	P7TF-IS16 DC24V	1 A	G7T-1122S DC24V	25 mA	G3TA-IDZR02S DC5-24V
16 outputs (DC coil)	NPN (+ common)	P7TF-OS16 DC12V	5 A	G7T-1112S DC12V	2 A	G3TA-ODX02S 12VDC
	NPN (+ common)	P7TF-OS16 DC24V	5 A	G7T-1112S DC24V	2 A	G3TA-ODX02S DC24V or
	PNP (- common)	P7TF-OS16-1 DC24V	5 A	G7T-1112S DC24V	1 A	G3TA-OD201S DC24V
8 outputs (DC coil)	NPN (+ common)	P7TF-OS08 DC12V	5 A	G7T-1112S DC12V	2 A	G3TA-ODX02S 12VDC
	NPN (+ common)	P7TF-OS08 DC24V	5 A	G7T-1112S DC24V	2 A	G3TA-ODX02S DC24V or
	PNP (- common)	P7TF-OS08-1 DC24V	5 A	G7T-1112S DC24V	1 A	G3TA-OD201S DC24V

G7TC-□□□□-□  
1 2 3 4

- 1. Input/Output Classification**  
I : For input  
O : For output
- 2. Type of I/O Signal**  
A : AC coil type for input relays mounted  
D : DC coil type for input relays mounted  
C : Contact output
- 3. Number of I/O Points**  
16: 16 points  
08: 8 points (for output only)
- 4. Internal I/O Circuit Common**  
Blank: NPN (+) common  
1: PNP (-) common
5. Block for use with DeviceNet

P7TF-□□□□-□  
1 2 3 4

- 1. Input/Output Classification**  
I : For input  
O : For output
- 2. Type of I/O Signal**  
S : Socket for input or output relays
- 3. Number of I/O Points**  
16: 16 points  
08: 8 points (for output only)
- 4. Internal I/O Circuit Common**  
Blank: NPN (+) common  
1: PNP (-) common

## ■ CONNECTOR CABLES

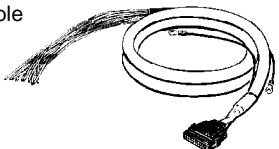
Item	Length	Part number
Connecting cable with crimp type hooks 	1.0 m (3.28 ft)	G79-Y100C
	1.5 m (4.92 ft)	G79-Y150C
	2.0 m (6.56 ft)	G79-Y200C
	3.0 m (9.84 ft)	G79-Y300C
	5.0 m (16.40 ft)	G79-Y500C
Connecting cable with connector on both ends 	1.0 m (3.28 ft)	G79-100C
	1.5 m (4.92 ft)	G79-150C
	2.0 m (6.56 ft)	G79-200C
	3.0 m (9.84 ft)	G79-300C
	5.0 m (16.40 ft)	G79-500C

## ■ ACCESSORIES (ORDER SEPARATELY)

Description	Part number
Single I/O socket for SPST and SPDT Relays	P7TF-05
Indicator module for AC (with varistor surge suppression)	P70A
Indicator module for DC (with diode surge suppression)	P70D
Output short circuit protection module	G77-5
Shorting bar	G78-04
Finger protection cover for 16-pt blocks	G78-E

## Specifications

### ■ RATINGS: G7T RELAYS

#### Coil Data (Common to Input/Output per Relay)

Rated voltage (V)	Rated current (mA)		Coil resistance (See Note 1)	Must operate	Must release	Maximum voltage	Power consumption	
	50 Hz	60 Hz					per Relay	per 16 Relays
AC	110/120 220/240	7.5/— 3.7/—	6.4/7.0 3.2/3.5	13,000 Ω 48,300 Ω	80% max.	30% min.	110%	0.7 VA 11 VA
DC	12	42		290 Ω	80% max.	10% min.	110%	0.5 W 8 W
DC	24	21		1,150 Ω	80% max.	10% min.	110%	0.5 W 8 W

Note: 1. The rated current and coil resistance are measured at a coil temperature of +23°C with a tolerance of +15%/-20% for AC rated current and ±15% for coil resistance.

2. Approx. 4 mA flows into each LED indicator. To calculate the power supply capacity, add the current value of each indicator.

## Contact Data (G7T I/O Relay)

Classification	For input		For output	
	Resistive load (cosφ=1)	Inductive load (cosφ=0.4 L/R=7 ms)	Resistive load (cosφ=1)	Inductive load (cosφ=0.4 L/R=7 ms)
Carry current	1 A		5 A	
Switching voltage	250 VAC, 125 VDC			
Switching current	1 A	0.5 A	5 A	2 A
Switching power	DC 24 W	DC 12 W	DC 120 W AC 440 VA	DC 48 W AC 220 VA
Min. permissible load	100 μA at 1 V		10 mA at 5 V	
Electrical life	10,000,000 operations (at 10 mA) 50,000 operations (at 1 A)	2,500,000 operations (at 10 mA) 20,000 operations (at 1 A)	1,000,000 operations (under rated load)	
Mechanical life	50,000,000 operations			

## ■ CHARACTERISTICS: G7T RELAYS

Model	G7TC-IA16 (Input, AC coil)	G7TC-ID16 (Input, DC coil)	G7TC-OC16 (-1) (Output, DC coil)	G7TC-OC08 (-1) (Output, DC coil)
LED color	Red	Green	Green	
Case color	Transparent red	Transparent green	Transparent	
Contact resistance	50 mΩ max.			
Operate time	15 ms max.			
Release time	15 ms max.			
Max. operating frequency	Mechanical limit	18,000 operations/hour		
	At rated load	1,800 operations/hour		
Insulation resistance	100 MΩ at 500 VDC			
Dielectric strength	Between coil and contact	2,000 VAC, 50/60 Hz for 1 minute		
	Between same polarity contacts	1,000 VAC, 50/60 Hz for 1 minute		
	Between paired connectors	250 VAC, 50/60 Hz for 1 minute		
Malfunction vibration	10 to 55 Hz with 1.0-mm double amplitude			
Malfunction shock	200 m/s <sup>2</sup>			
Noise immunity	Noise level: 1.5 kV; pulse width: 100 ns to 1 μs			
Rated voltage between positive and negative terminal blocks	Rated voltage of controller's (PLC or other) input circuit		24 VDC ±5%	
Rated current between positive and negative terminal blocks	Input circuit current of controller (PLC or other) x number of ON points		24 VDC: 25 mA x number of ON points	
Cable length	To controller	5 m max. (reference value)		
	To I/O devices	50 m max. (reference value, for 2-mm <sup>2</sup> CVV cable)		Dependent on load
Ambient operating temperature	0°C to 55°C (32°F to 131°F)			
Ambient operating humidity	35% to 85%			
I/O terminal tightening torque	8 to 12 kg • cm			
Coil surge absorber	Variable resistor	Diode (1 A, 400 V)		
Weight	Approx. 640 g	Approx. 630 g	Approx. 670 g	Approx. 350 g

## UL and CSA Standards

Standard G7TC I/O Blocks, except for the G7TC-OC16-1 and the G7TC-OC08(-1), have met UL and CSA standards (UL file no. E41643; CSA file no. LR31928).

Note that the following UL- and CSA-qualifying ratings differ from the performance characteristics of the individual models:

Part number	Coil ratings	Contact ratings
G7TC-ID16, G7TC-IA16	10 mA/point, 24 VDC	250 VAC max.
G7TC-OC16	Coil drive current, 24 VDC	Inductive load: 10 A, 250 VAC Resistive load: 10 A, 30 VDC Rated horsepower: 1/2 HP, 240 VAC

## ■ RATINGS: G3TA SOLID STATE RELAYS

### Input Relay

#### Coil Data

Part number	Rated voltage	Operating voltage	Input current	Voltage level	
				Must operate voltage	Must release voltage
G3TA-IAZR02S AC100/240V	100 to 240 VAC	80 to 264 VDC	5 mA max.	80 VAC max.	10 VAC min.
G3TA-IDZR02S DC5-24V	5 to 24 VDC	4 to 32 VDC		4 VDC max.	1 VDC min.

#### Contact Data

Part number	Logic level supply voltage	Output breakdown voltage	Output current	Output current (load current)
G3TA-IAZR02S AC100/240V	4 to 32 VDC	32 VDC max.	25 mA max.	0.1 to 25 mA
G3TA-IDZR02S DC5-24V				

### Output Relay

#### Coil Data

Part number	Rated voltage	Operating voltage	Input impedance	Voltage level	
				Must operate voltage	Must release voltage
G3TA-OA202SZ DC12V	12 VDC	9.6 to 13.2 VDC	0.9 k $\Omega$ ±20%	9.6 VDC max.	2 VDC min.
G3TA-OA202SZ DC24V	24 VDC	19.2 to 26.4 VDC	1.7 k $\Omega$ ±20%	19.2 VDC max.	
G3TA-ODX02S DC24V	12 VDC	9.6 to 13.2 VDC	3.5 k $\Omega$ ±20%	9.6 VDC max.	
	24 VDC	19.2 to 26.4 VDC	6.5 k $\Omega$ ±20%	19.2 VDC max.	
G3TA-OD201S DC24V	24 VDC	19.2 to 26.4 VDC	6.4 k $\Omega$ ±20%	19.2 VDC max.	

#### Contact Data

Part number	Applicable load			
	Rated load voltage	Load voltage	Load current (See Note)	Inrush current
G3TA-OA202SZ	100 to 240 VAC	75 to 264 VAC	0.05 to 2 A	30 A (60 Hz, 1 cycle)
G3TA-OA202SL	100 to 240 VAC	75 to 264 VAC		
G3TA-ODX02S	5 to 48 VDC	4 to 60 VDC	0.01 to 2 A	12 A (10 ms)
G3TA-OD201S	48 to 200 VDC	40 to 200 VDC	0.01 to 1 A	6 A (10 ms)

Note: The minimum current value is measured at 10°C min.

## ■ CHARACTERISTICS: G3TA SOLID STATE RELAYS

### Input Relay

Item	G3TA-IAZR02S	G3TA-IDZR02S
Operate time	20 ms max.	0.5 ms max.
Release time	20 ms max.	0.5 ms max.
Output ON voltage drop	1.6 V max.	
Leakage current	5 $\mu$ A max.	
Insulation resistance	100 M $\Omega$ min. at 500 VDC	
Dielectric strength	4,000 VAC, 50/60 Hz for 1 min between input and output	
Vibration resistance	Malfunction: 10 to 55 Hz, 1.5-mm double amplitude	
Shock resistance	Malfunction: 1,000 m/s <sup>2</sup> (approx. 100G)	
Ambient temperature	Operating: -30°C to 80°C (-22°F to 176°F) with no icing or condensation Storage: -30°C to 100°C (-22°F to 212°F) with no icing or condensation	
Ambient humidity	Operating: 45% to 85%	
Approved standards	UL508 file No. E64562/CSA C22.2 (No. 0, No. 14) file No. LR35535	
Weight	Approx. 16 g	

### Output Relay

Item	G3TA-OA202SZ	G3TA-ODX02S	G3TA-OD201S
Operate time	1/2 of load power source cycle + 1 ms max.	0.5 ms max.	2 ms max.
Release time	1/2 of load power source cycle + 1 ms max.	2 ms max.	2 ms max.
Output ON voltage drop	1.6 V max.		2.5 V max.
Leakage current	5 mA max. at 200 VAC	1 mA max.	
Insulation resistance	100 M $\Omega$ min. at 500 VDC		
Dielectric strength	4,000 VAC, 50/60 Hz for 1 min between input and output		
Vibration resistance	Malfunction: 10 to 55 Hz, 1.5-mm double amplitude		
Shock resistance	Malfunction: 1,000 m/s <sup>2</sup> (approx. 100G)		
Ambient temperature	Operating: -30°C to 80°C (-22°F to 176°F) with no icing or condensation Storage: -30°C to 100°C (-22°F to 212°F) with no icing or condensation		
Ambient humidity	Operating: 45% to 85%		
Approved standards	UL508 file No. E64562, CSA C22.2 (No. 14) file No. LR3553		
Weight	Approx. 23 g		

## ■ MIXING G3TA WITH G7T RELAYS IN THE SAME I/O BLOCK

With up to four G3TA SSRs mounted before G7T Relays, 2-A loads can be switched.

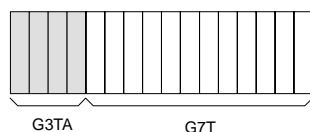

With G3TA SSRs mounted before every other G7T Relays, 2-A loads can be switched.

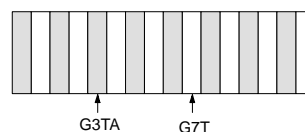

# Engineering Data

## ■ G7T RELAYS

**Life Expectancy of Output**

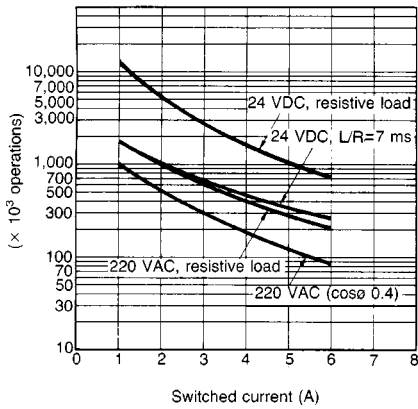

**Max. Switching Capacity of Output**  
(Life expectancy: 1,000,000 Operations)

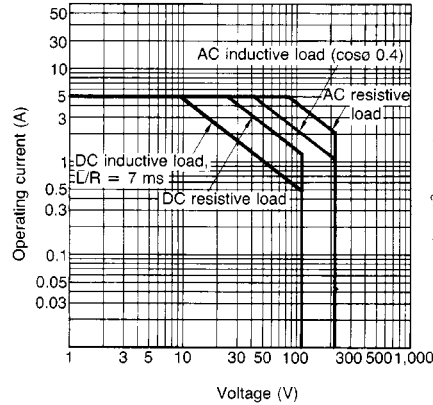

**Life Expectancy of Input**

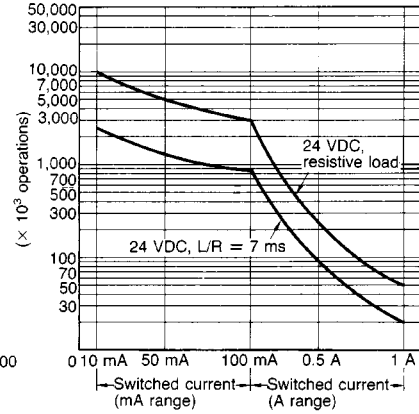

## ■ G3TA SOLID STATE RELAYS

**Load Current vs. Ambient Temperature Characteristics**

**G3TA-OA202SZ/OA202SL/ODX02S**

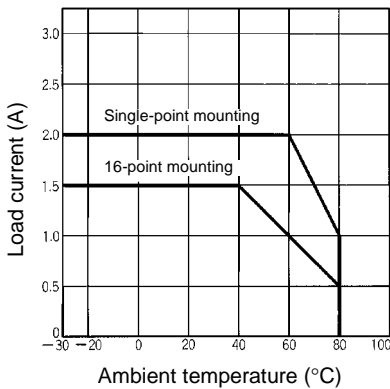

**G3TA-OD201S**

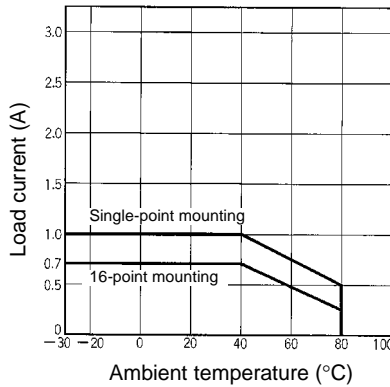

### Inrush Current

Non-repetitive (Keep the inrush current to half the rated value if it occurs repetitively.)

**G3TA-OA202SZ**

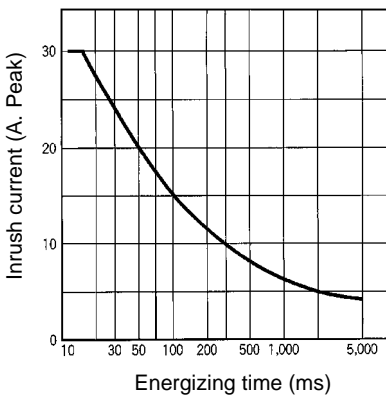

**G3TA-ODX02S**

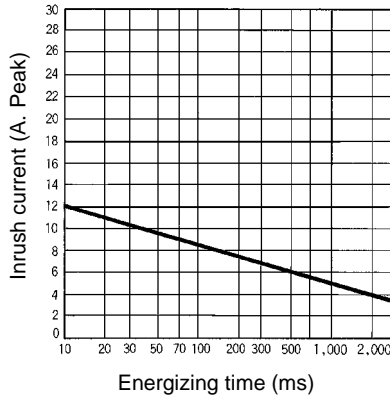

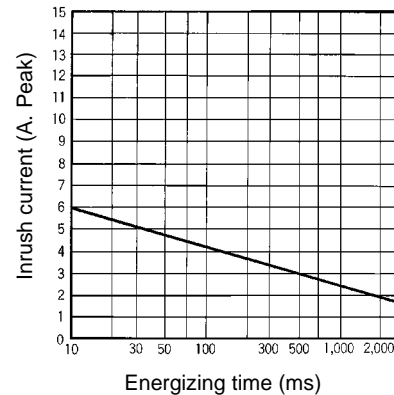

**G3TA-OD201S**



# Operation

## ■ G3TA SOLID STATE RELAYS

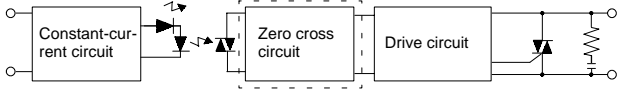
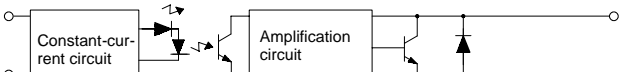
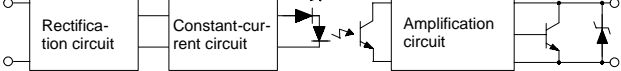
### Circuit Configuration

Type	Part number	Case color	Indicator	Circuit
AC output	G3TA-OA202SZ (with zero cross function) G3TA-OA202SL (without zero cross function)	Black	Yes	
DC output	G3TA-ODX02S G3TA-OD201S	Black	Yes	
AC input	G3TA-IAZR02S	Red	Yes	
DC input	G3TA-IDZR02S	Green	Yes	
	G3TA-IDZR02SM		No	

### External Connections (Bottom View)

**G3TA-IAZR02S**

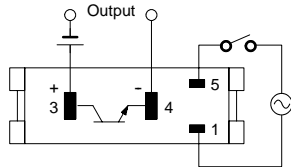

**G3TA-IDZR02S/IDZR02SM**

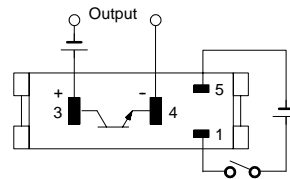

**G3TA-OA**

Load power supply

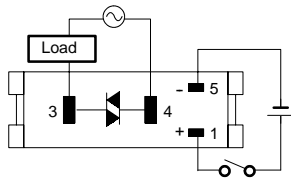

**G3TA-OD**

Load power supply

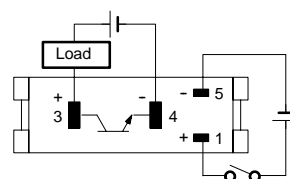

# Dimensions

Unit: mm (inch)

## ■ G7TC RELAY I/O BLOCKS

### I/O Block for NPN Input ( $\ominus$ common)

G7TC-ID16  
G7TC-IA16

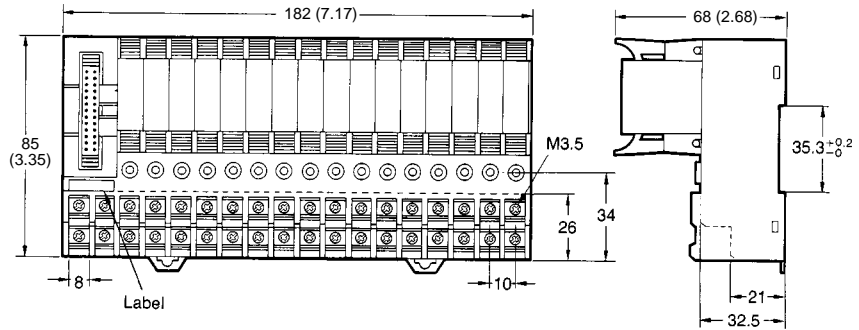
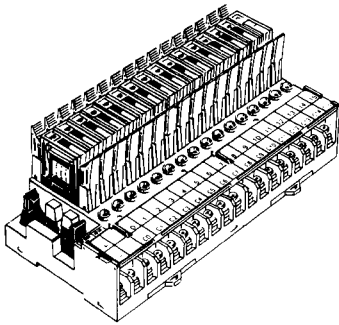

### Terminal Arrangement/Internal Connection

G7TC-ID16 (-5)  
(See Note)

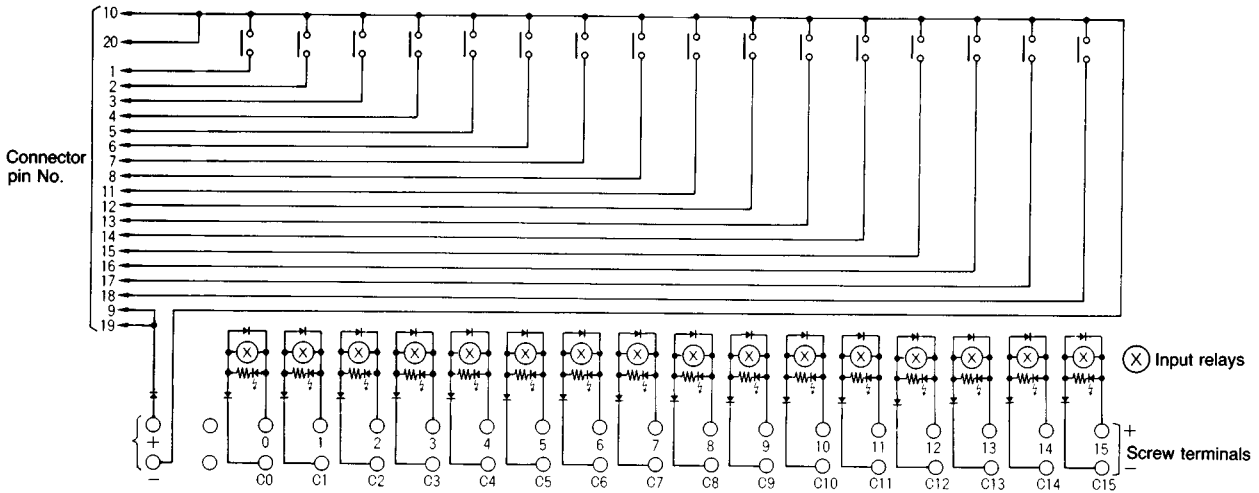

Note: When the product has a "-5" at the end of the part number, connector pin number 9 and 19 are negative and connector number 10 and 20 are positive.



**G7TC-IA16 (-5)**  
(See Note)

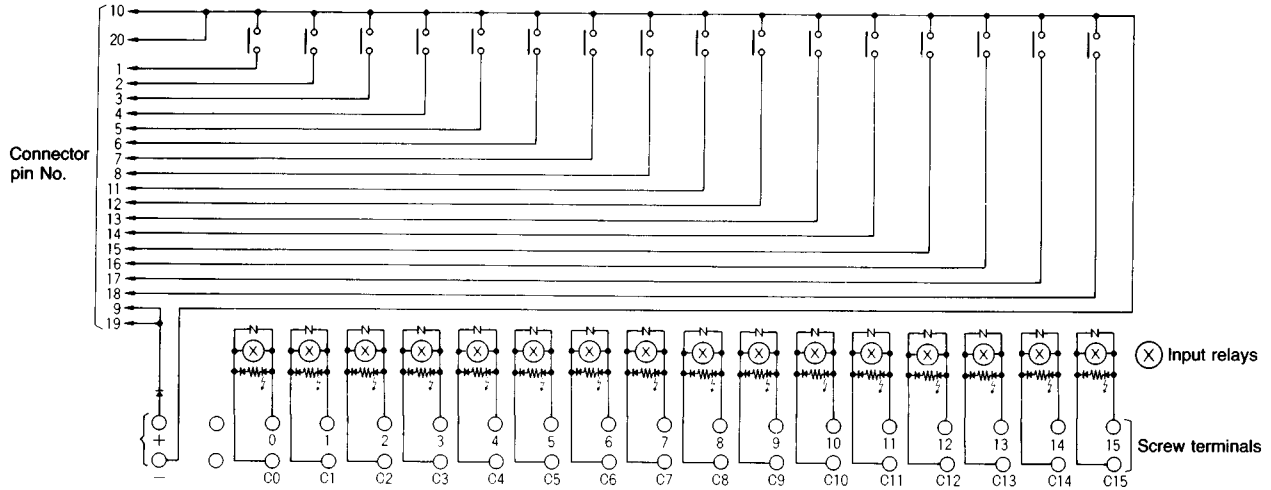

Note: When the product has a "-5" at the end of the part number, connector pin number 9 and 19 are negative and connector pin number 10 and 20 are positive.

**I/O Block for Output**

- G7TC-OC16 (NPN output/⊕ common)
- G7TC-OC16-1 (PNP output/⊖ common)
- G7TC-OC8 (NPN output/⊕ common)
- G7TC-OC8-1 (PNP output/⊖ common)

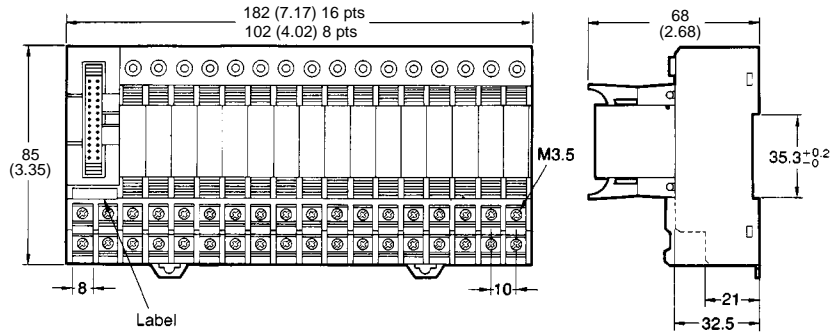
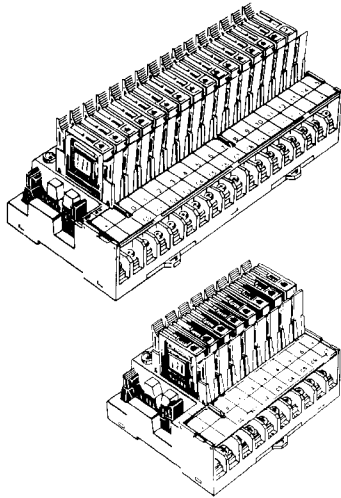

Terminal Arrangement/Internal Connection

G7TC-OC16

A controller with an NPN transistor, common output can be connected to the G7TC-OC16.

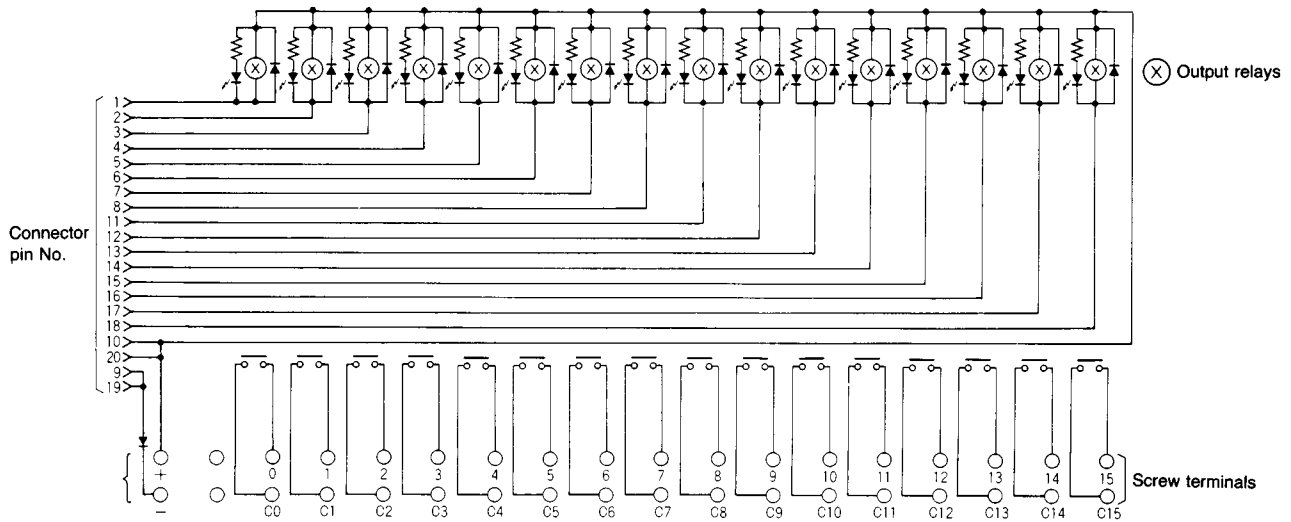

G7TC-OC16-1 (PNP output/⊖ common)

A controller with a PNP transistor, common output can be connected to the G7TC-OC16-1. Do not connect the G71 Remote Interface to the G7TC-OC16-1. Due to the difference in polarity, the G71 will be damaged if the G7TC-OC16-1 and the G71 are connected to each other. Use the G7TC-OC16 (NPN output/⊕ common) instead, to connect to the G71.

Terminal Arrangement/Internal Connection

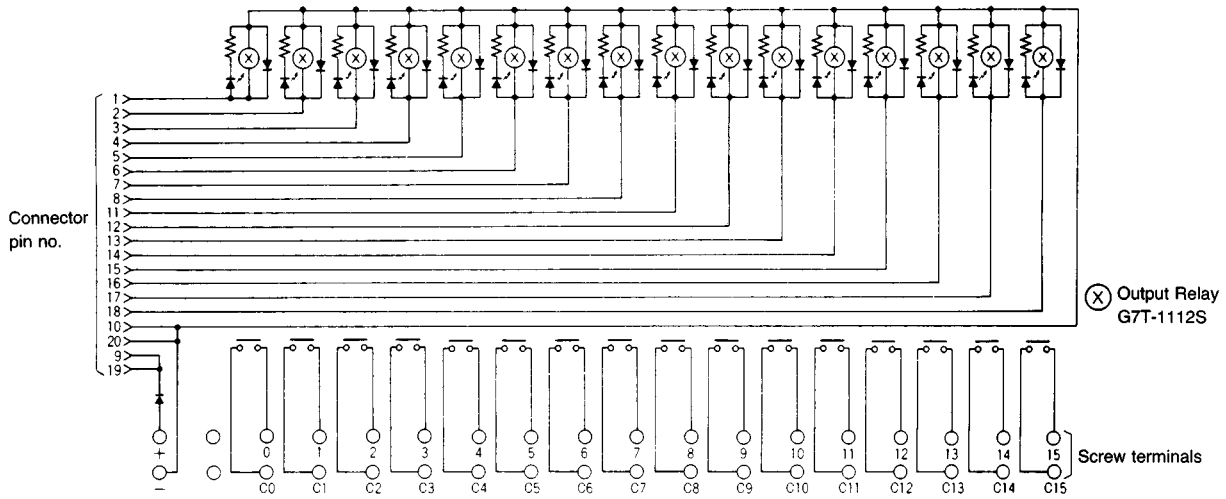

**G7TC-OC08**

A controller with an NPN transistor, common output can be connected to the G7TC-OC08.

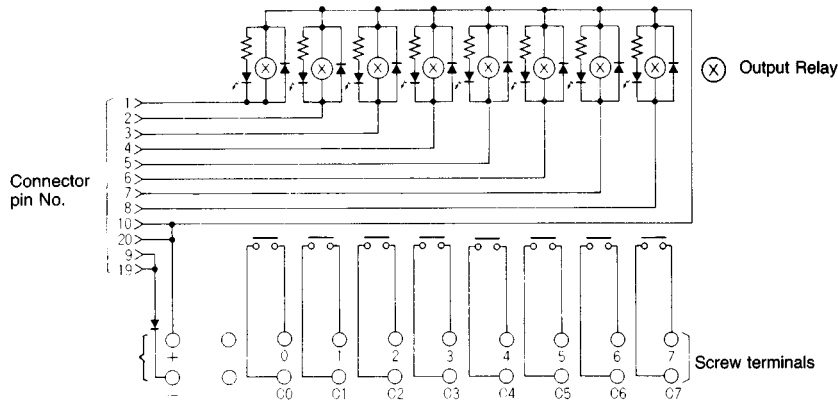

**G7TC-OC08-1 (PNP output/⊖ common)**

A controller with a PNP transistor, common output can be connected to the G7TC-OC08-1. Do not connect the G7TC-OC08-1 with the G71. Due to the difference in polarity, the G71 will be damaged if the G7TC-OC08-1 and the G71 are connected to each other. Use the G7TC-OC08 (NPN output/⊕ common) instead, to connect to the G71.

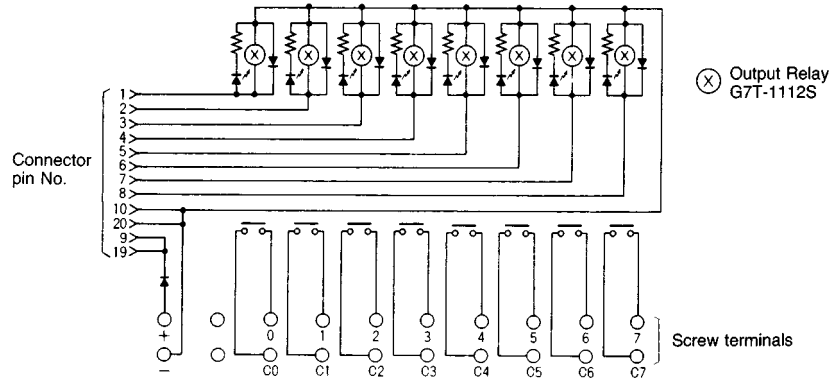

**Connector Pin Configuration  
Top View**

I/O indications on Screw Terminals of G7TC-ID16, G7TC-IA16, G7TC-OC16-1, and G7TC-OC08-1

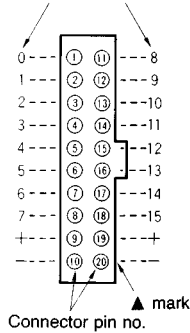

I/O Numbers Allocated to Screw Terminals of G7TC-OC16 and G7TC-OC08

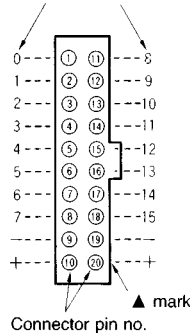

Note: Pin numbers are indicated for convenience. The ▲ mark can be used to determine orientation.

**G7T RELAY**

Unit: mm (inch)

**SPST-NO Type**  
**G7T-1122S (for input)**  
**G7T-1112S (for output)**

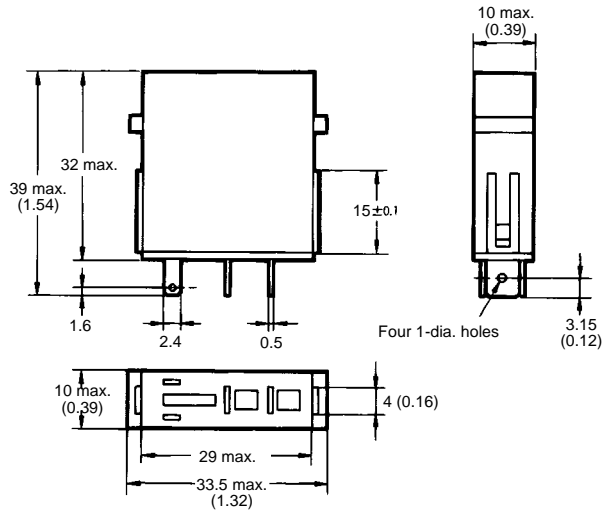
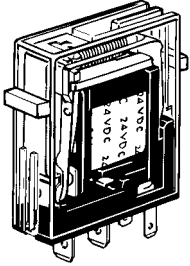

**Terminal Arrangement/  
 Internal Connections  
 (Bottom View)**

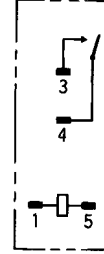

**SPST-NC Type**  
**G7T-1012S (for output)**

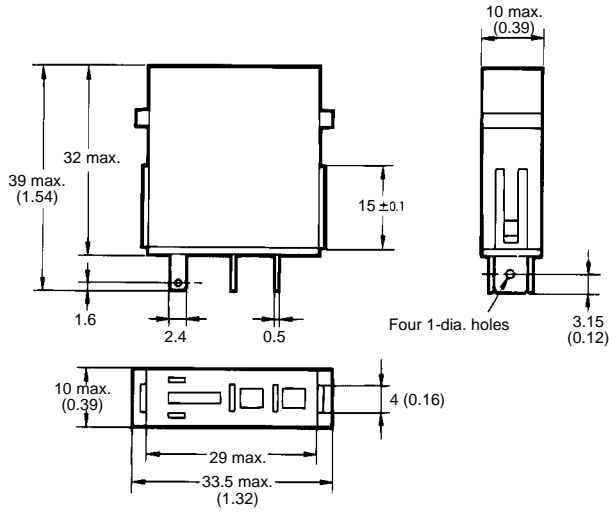
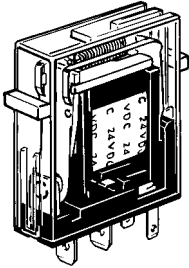

**Terminal Arrangement/  
 Internal Connections  
 (Bottom View)**

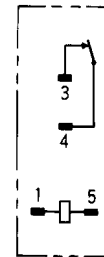

**G3TA SOLID STATE RELAYS**

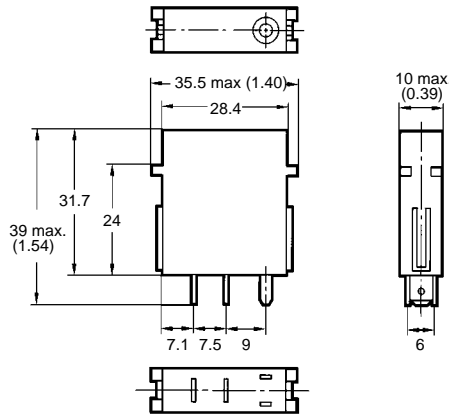
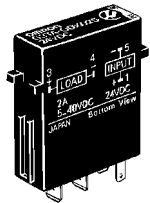

Unit: mm (inch)

■ P7TF BLOCK BASES

For Input (NPN, ⊖ Common)  
P7TF-IS16

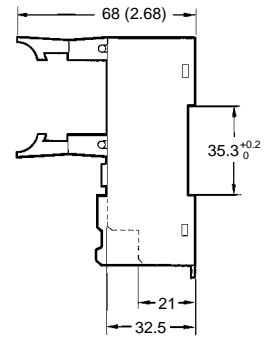
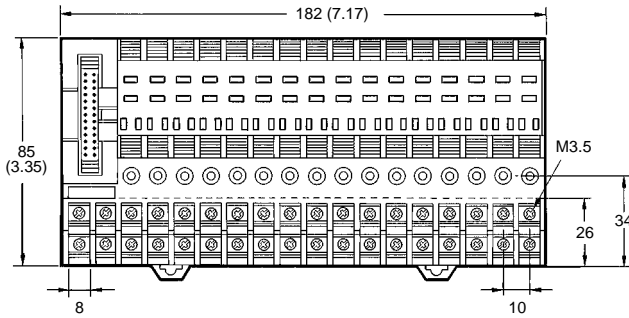
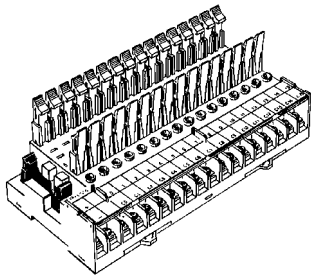

For Output (NPN, ⊕ Common)  
P7TF-OS16

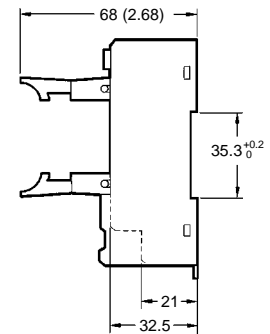
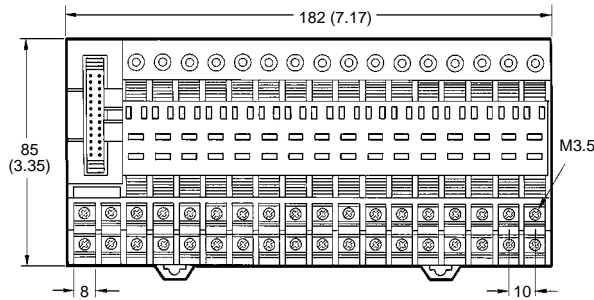
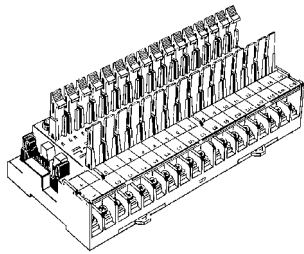

For Output (PNP, ⊖ Common)  
P7TF-OS08

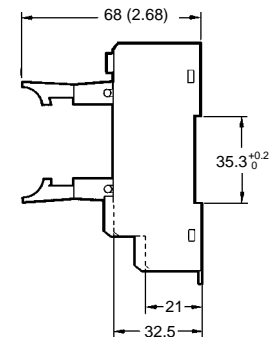
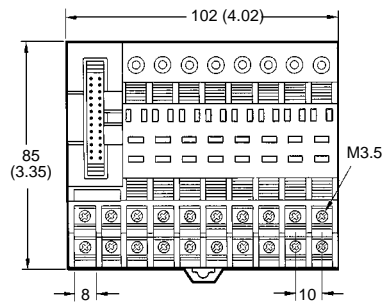
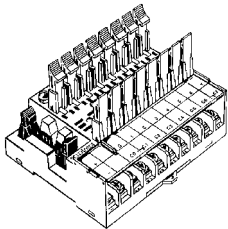

P7TF-05

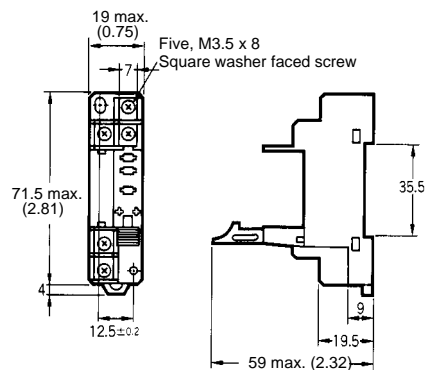
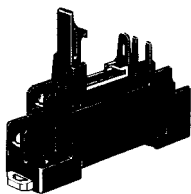

**G7TC Internal I/O Circuit Common**

**NPN Output**

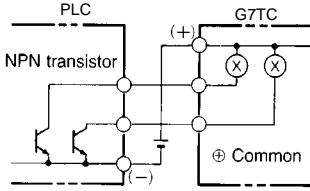

**Input**

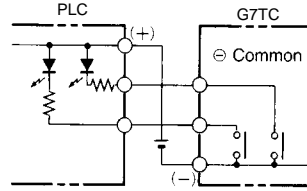

**PNP Output (Output Only)**

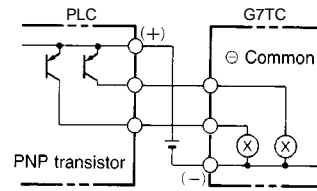

# Accessories (Order Separately)

■ **G79 CONNECTING CABLES**

**G79 Connecting Cable with Crimp-type Hooks**

Use these convenient Cables to connect relay I/O Blocks to devices equipped with screw terminals. Power line capacity must be within 50 mA per I/O point. Always check driver capacity and I/O relay power consumption when using an Output Block. Hoods are labeled with corresponding connector pin numbers. Connect hooks 9 and 19 and hooks 10 and 20 together when using the G7TC-OC08.

Length (ℓ)	Part number
1,000 mm	G79-Y100C
1,500 mm	G79-Y150C
2,000 mm	G79-Y200C
3,000 mm	G79-Y300C
5,000 mm	G79-Y500C

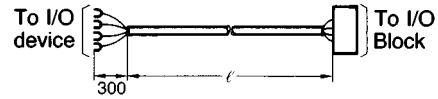
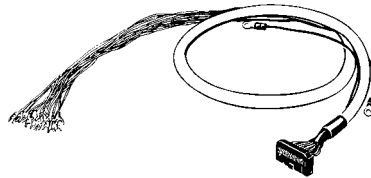

**G79 Connecting Cable with One-to-One Connector**

This Cable is convenient for connecting a Relay I/O Block to a single device equipped with one connector socket.

Length (ℓ)	Part number
1,000 mm	G79-100C
1,500 mm	G79-150C
2,000 mm	G79-200C
3,000 mm	G79-300C
5,000 mm	G79-500C

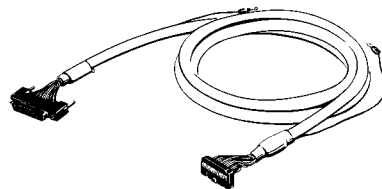

## ■ G7TC TO PLC MODULE CONNECTION OPTIONS

### One-to-One Connections: (16 Points per Cable)

The connecting cables with crimp hooks allow G7TC and P7TF blocks to be used with PLCs from all manufacturers.

Relay block	Omron PLC module	Connection method to PLC	Connecting cable
<b>Inputs</b>			
G7TC-1A16 G7TC-ID16 P7TF-IS16	3G2A5-ID213 (16 pts) 3G2A5-IM211 (16 pts) C200H-ID212 (16 pts) C200H-IM212 (16 pts) CQM1-ID212 (16 pts)	Crimp hooks	G79-Y___C
	C500-MD211CN (input side only) C200H-MD215 (input side only) C200H-ID215 (32 pts)	One-to-one connector	G79-___C G79-___C (2)
<b>Outputs</b>			
G7TC-OC16 P7TF-OS16	3G2A5-OC221 (16 pts) 3G2A5-OC223 (16 pts) 3G2A5-OD215 (16 pts) 3G2A5-OD411 (16 pts) C200H-OC225 (16 pts) C200H-OD212 (16 pts) CQM1-OC222 (16 pts) CQM1-OD212 (16 pts)	Crimp hooks	G79-Y___C
	C500-OD415CN (16 pts) C500-MD211CN (output side only) C200H-MD115 (output side only) C200H-MD215 (output side only) C200H-OD215 (16 pts)	One-to-one connector	G79-___C

### One-to-Two Connections: (Cable Splits One Connector to Two Relay Blocks)

Relay block	PLC module	Connection method to PLC	Connecting cable
<b>Inputs</b>			
G7TC-1A16 G7TC-ID16 P7TF-IS16	3G2A5-ID219 (64 pts) C500-ID114 (64 pts) C500-ID218CN (32 pts) C200H-ID216 (32 pts) C200H-ID217 (64 pts) CQM1-ID213 (32 pts)	Special cable that splits a single connector at the PLC to two at the relay blocks	G79-I___C___ (2 are required for 64-pt modules)
	<b>Outputs</b>		
G7TC-OC16 P7TF-OS16	3G2A5-OD213 (64 pts) C500-OD218 (32 pts) C500-OD415CN (32 pts) C200H-OD218 (32 pts) CQM1-OD219 (64 pts)	Special cable that splits a single connector at the PLC to two at the relay blocks	G79-O___C___ (2 are required for 64-pt modules)

### High-density Connections (Cable Splits One Connector to Three Relay Blocks)

Relay block	PLC module	Connection method to PLC	Connecting cable
<b>Inputs</b>			
G7TC-1A16 G7TC-ID16 P7TF-IS16	CS1W-ID291 (96 pts) CS1W-MD291 (48 pts, input side only)	Special cable that splits a single connector at the PLC to three at the relay blocks	G79-___C - ___ - ___ (2 are required for 96-pt modules)
	<b>Outputs</b>		
G7TC-OC16 P7TF-OS16	CS1W-OD219 (96 pts) CS1W-MD291 (48 pts, output side only)	Special cable that splits a single connector at the PLC to three at the relay blocks	G79-___C - ___ - ___ (2 are required for 96-pt modules)

Unit: mm (inch)

**SHORTING BAR**

**G78-04**

Use this piece for short-circuiting across terminals.  
Max. current flow: 20 A

Item	Part number
Shorting bar	<b>G78-04</b>

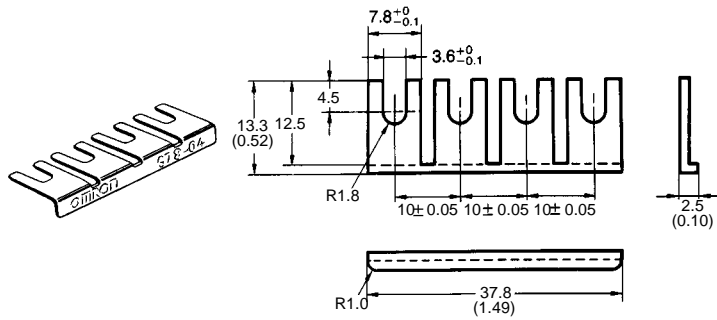

**FINGER PROTECTION COVER FOR G7TC OR P7TF (MEETS VDE 0106 PART 100)**

**G78-E**

This cover is for 16-point relay blocks only and cannot be used with an 8-point relay block.

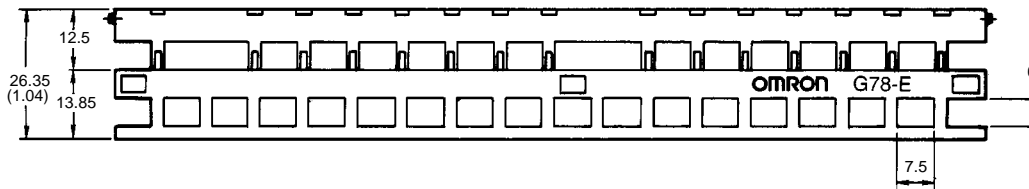
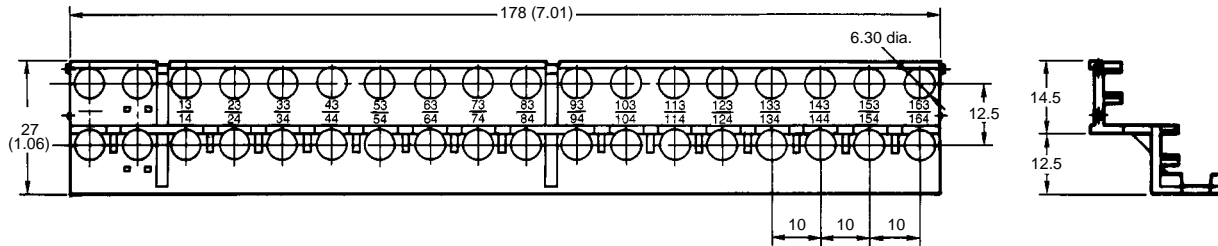



# I/O Block Details

## INPUT BLOCKS

**G7TC-ID16**  
**G7TC-IA16**

Supply power to terminals 0 through 15 and C0 through C15 according to the voltage specifications of the I/O Relays and I/O Block. Do not reverse positive and negative terminals on the DC Input Block (0 through 15 are positive; C0 through C15, negative). Shorting bars are available.

Supply to the power terminal (positive and negative) the rated voltage of the controller's input circuits (24, 12). Use a low-noise power source.

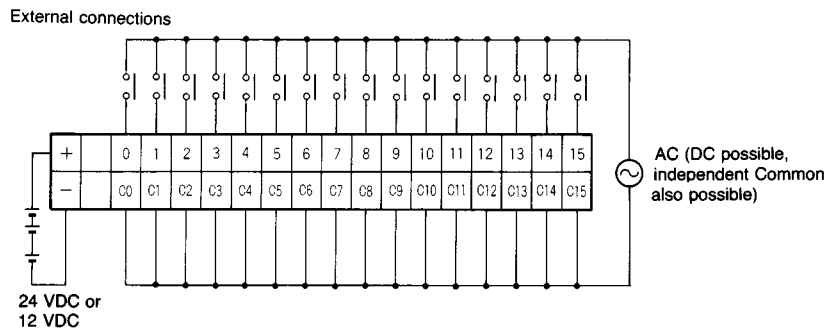
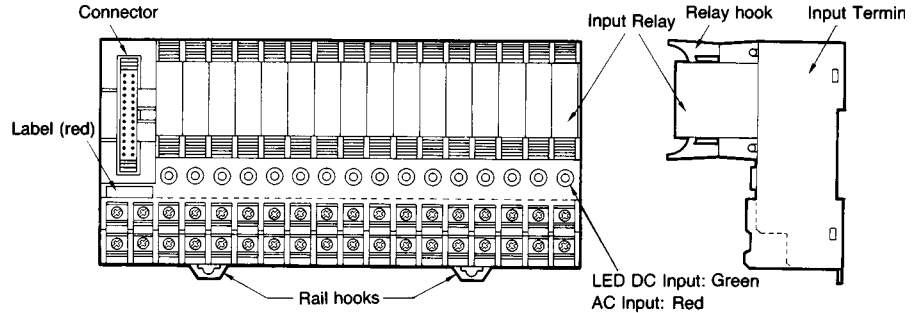

## OUTPUT BLOCKS

**G7TC-OC16(-1)**  
**G7TC-OC08(-1)**

Supply power to contact output terminals 0 through 15 and C0 through C15 according to the requirements of the loads. A 4 terminal Shorting Bar is available.

Supply to the power terminals (positive and negative) power both for driving the relays and for controller output transistors. Match the controller and I/O block voltage specifications. Use a low-noise power source.

Output Block model G7TC-OC08 does not have terminals 8 through 15 and C8 through C15. Although a 20-pin connector is used, pins 11 through 18 are not connected.

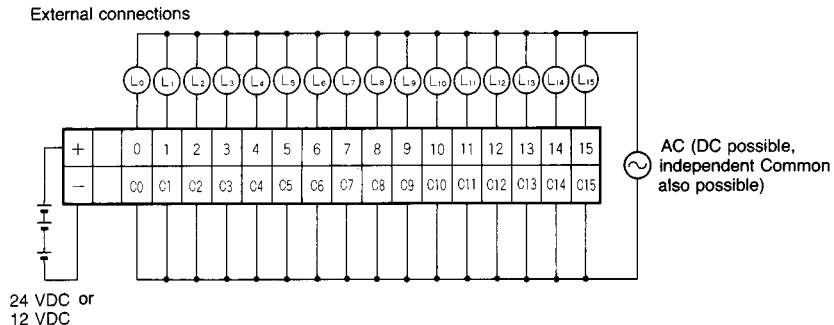
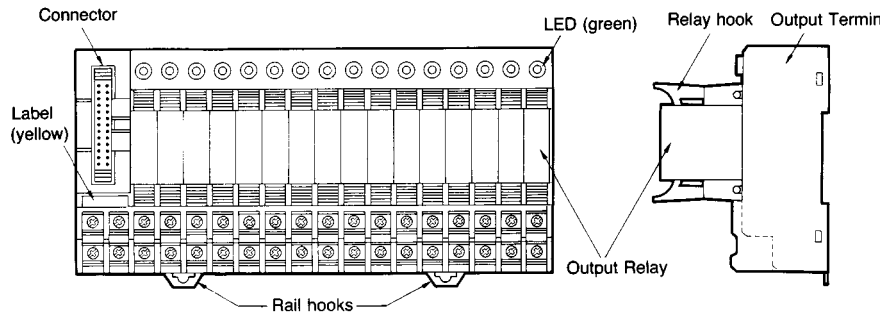

# To Increase the Number of Outputs

Use sockets (order separately) to increase the number of outputs or to use SPDT I/O Relays on the G7TC.

## EXTERNAL CONNECTION EXAMPLE

The following is an application example for the P7TF-05 using a SPDT Relay on a terminal of the G7TC-16(-1).

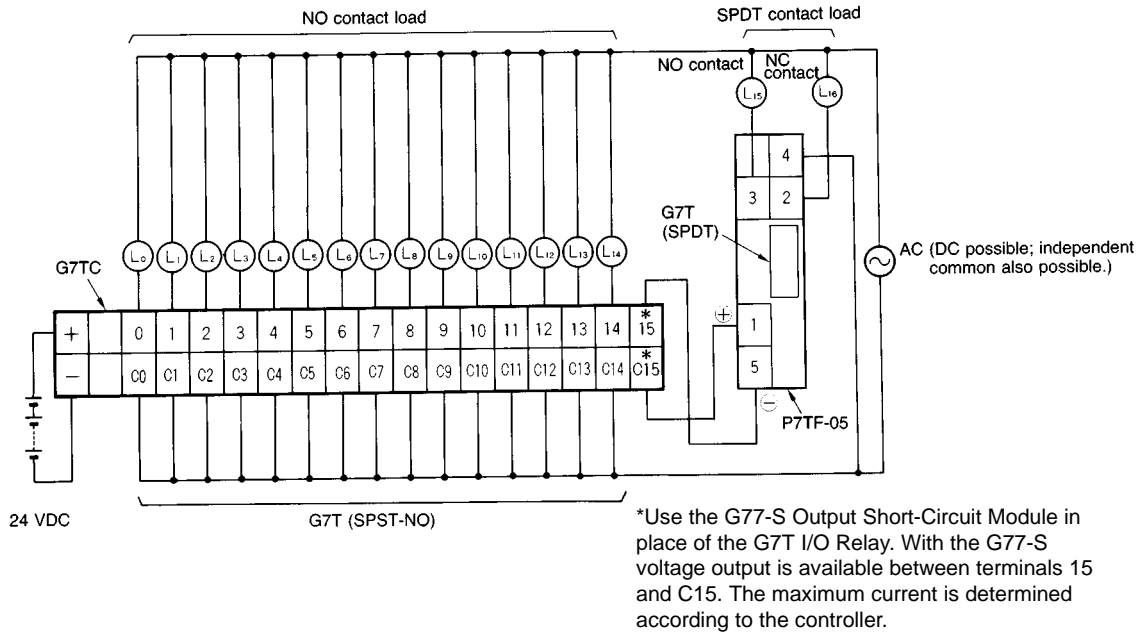

Note: If more than one G77-S Output Short-Circuit Module is employed, the voltage output of the terminals on the G7TC is as follows:  
 G7TC-OS16: The positive side (the lower row) connects to the common line internally.  
 G7TC-OS16-1: The negative side (the upper row) connects to the common line internally.

## P7TF-05 SOCKET

The G7T Relays (SPST-NO, SPST-NC, and SPDT types) and the G3TA I/O Relays can be mounted on the P7TF-05 Socket.

To add SPDT relays (G7T-112S) to a G7TC or P7TF installation, use the G77-S Output Short-Circuit Module and the P7TF-05 Socket.

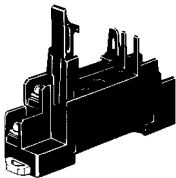

### Specifications

<b>Contact resistance</b>	10 mΩ max.
<b>Dielectric strength</b>	2,000 VAC for 1 minute
<b>Insulation resistance</b>	100 MΩ at 500 V
<b>Vibration</b>	10 to 55 Hz, 1.0 mm double amplitude
<b>Shock</b>	200 m/s <sup>2</sup>
<b>Ambient temperature</b>	Operating: 0 to 55°C (32°F to 131°F)
<b>Humidity</b>	35% to 85%
<b>Weight</b>	Approx. 28 g

Unit: mm (inch)

**Dimensions**

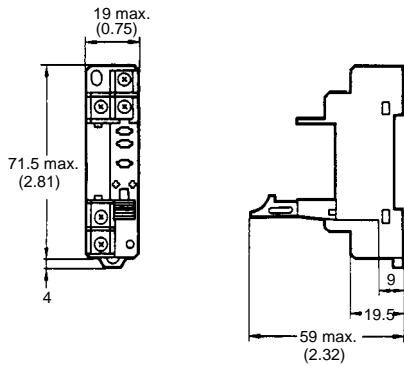

**Internal Connections  
(Top View)**

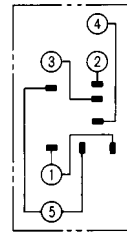

Note: Terminal 1 is positive when the I/O SSR is employed.

**■ P70 INDICATOR MODULE (WITH SURGE SUPPRESSING FUNCTION)**

Remove the transparent style strip of the P7TF-05 socket and mount this module and it will function as an operation indicator with the surge suppression.

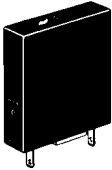

Part number		Applicable relay coil voltage	Remarks
For AC relay	P70A	110/120 VAC	Surge suppressing system with varistor
		220/240 VAC	
For DC relay	P70D	12/24 VDC	Surge suppressing system with diode

- Note: 1. Order the indicator module suitable for the relay coil voltage.  
 2. The indicator module for DC relays has a multiple power supply common to both 12 and 24 VDC.

**Dimensions**

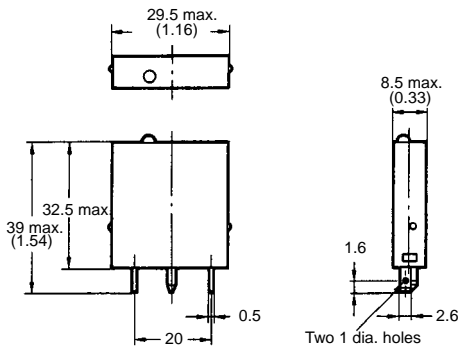

**Internal Connection**

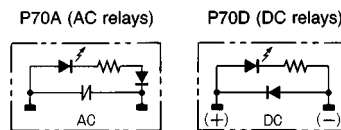

Unit: mm (inch)

**G77-S OUTPUT SHORT-CIRCUIT MODULE**

The output of the I/O Block can be obtained without relays through the G77-S Output Short-Circuit Module. Note that the G77-S Output Short-Circuit Module is not available for inputs.

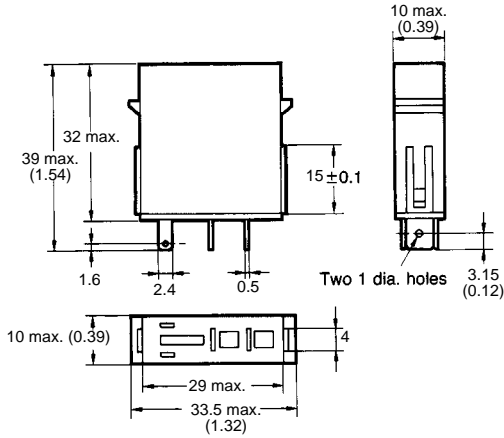
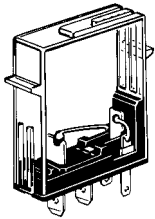

**Terminal Arrangement/Internal Connections (Bottom View)**

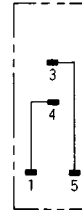

**Precautions**

**CORRECT INSTALLATION**

I/O Blocks are color coded, as shown below, according to input/output and AC/DC specifications.

Block type	I/O Terminal label	I/O Terminal indicators	I/O Relay case
Output Block (DC)	Yellow	Green	Transparent
Input Block	DC	Red	Green
	AC	Red	Red

Both Input and Output Blocks do not have internal power supplies. For an Output Block, supply the relay drive power to the positive and negative terminals (either 12 or 24 VDC). Loads (terminal contacts 0 through 15) must also be supplied with appropriate power. For an Input Block, supply power to the positive and negative terminals for the input signals to the controller.

The same Connecting Cable, G79-Y, is used for the G7TC-OC08 eight-point Output Block as for other I/O Blocks; leave 8 points unconnected.

LEDs indicate the presence or absence of signals. Use the display lever inside each relay for fault diagnosis. (Some relays do not have this lever, depending on the specifications.)

Each relay must be pressed down until its hold-down hooks engage completely. Heating or malfunction can result if relays are not mounted properly.

Unlabeled terminals are not electrically connected. Use these for repeater terminals.

LED positions and relay orientation differ between Input and Output Blocks. This is to aid in differentiating Input Blocks from Output Blocks and in following signal flow. DC I/O Blocks have positive and negative terminals, with the positive terminals normally on the top of the I/O Block. Reversing positive and negative terminals will prevent operation.

Rails are generally used to mount Relay I/O Blocks. For screw mounting, a 210-mm DIN rail is available that can be used as an adapter in combination with End Plates (PFP-M, two required).

**USING A SHORTING BAR**

A Shorting Bar is provided to connect four terminals. The current capacity of the shorting bar is 20 A. As long as this current capacity is not exceeded, the shorting bar can be used in combination as shown at the right to connect more than four terminals.

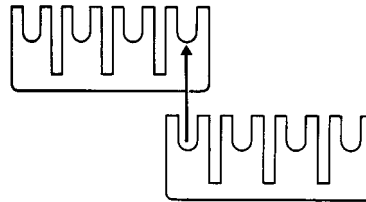

Operational errors can result if connectors are connected or removed with power supplied to the I/O Block.

**NOTE: DIMENSIONS SHOWN ARE IN MILLIMETERS. To convert millimeters to inches divide by 25.4.**

---

**OMRON**<sup>®</sup>  
**OMRON ELECTRONICS, INC.**  
One East Commerce Drive  
Schaumburg, IL 60173  
**1-800-55-OMRON**

**OMRON CANADA, INC.**  
885 Milner Avenue  
Scarborough, Ontario M1B 5V8  
**416-286-6465**