

REVISION					
ZONE	LTR	ECN	DESCRIPTION	DATE	APPROVED
	D	41239	ADD .325 MIN TIN DIMENSION	1/16/02	TL

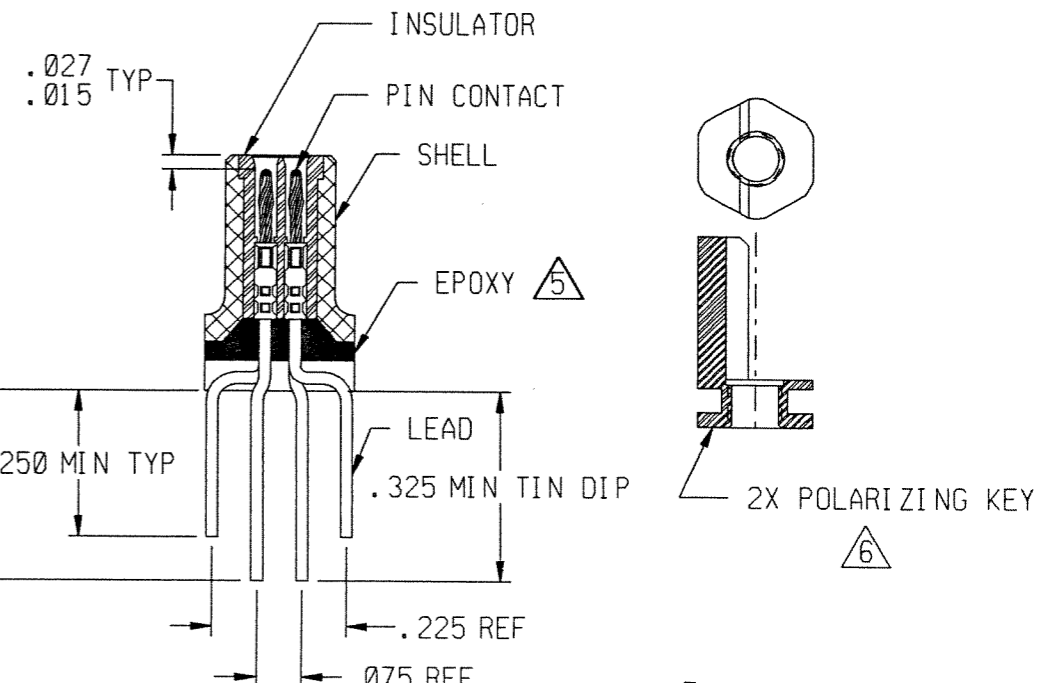
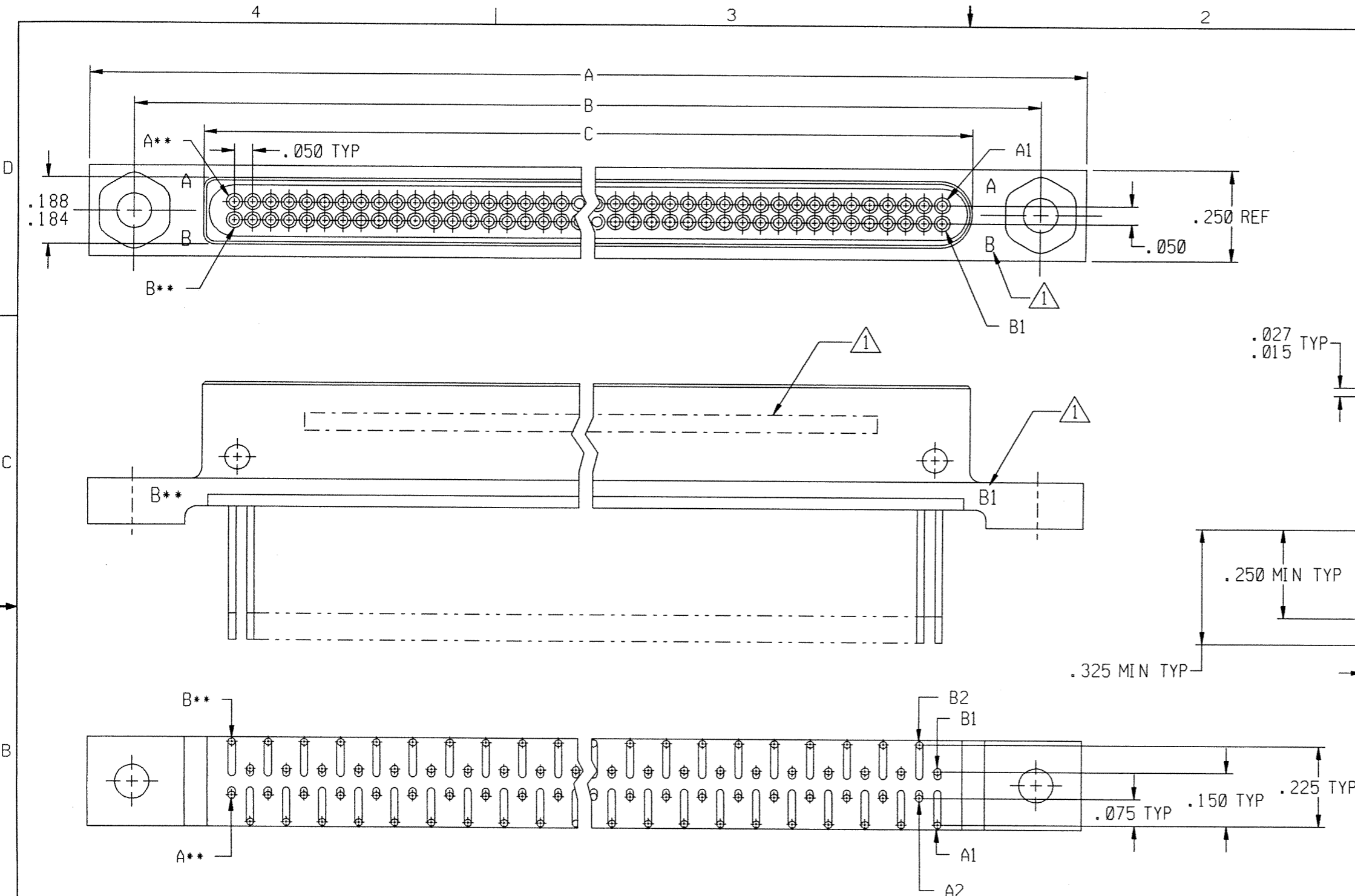

Tyco Dwg 4-1532143-8  
Micro P/N 095-0000-0462

CAVITY NO.	PART NUMBER	A	B	C
40	095-0087-2101	1.750	1.500	1.119/1.122
44	095-0087-3102	1.850	1.600	1.219/1.222
80	095-0087-5102	2.750	2.500	2.119/2.122
110	095-0087-6102	3.500	3.250	2.869/2.872
128	095-0087-7127	3.950	3.700	3.319/3.322
152	095-0087-4001	4.550	4.300	3.919/3.922

NOTES: UNLESS OTHERWISE SPECIFIED

1. MARK PER TIS (\*\* : 1/2 OF TOTAL NUMBER OF CAVITIES, EX: \*\* = 64 FOR 128 CAVIITES).
2. CRIMP LEADS INTO CONTACTS PER MEP 302-05.
3. FORM TERMINAL WIRES AS SHOWN. NO SCRATCHES EXPOSING BASE METAL PERMITTED ON WIRES AFTER FORMING.
4. THE 90° BEND IN THE TERMINAL WIRES SHALL NOT EXTEND BELOW THE PLANE OF THE MOUNTING FLANGE.
5. EPOXY AS SHOWN USING P/N: 194-8102-6215/6225.
6. TWO POLARIZING KEYS SUPPLIED UNASSEMBLED.

UNLESS OTHERWISE SPECIFIED DIMENSIONS ARE IN INCHES. TOLERANCE ARE: FRACTIONS ± 1/8 DECIMALS .XX ± .01 .XXX ± .005 ANGLES ± 2°	APPROVALS		 <b>MICRODOT CONNECTORS</b> A DIVISION OF UNI-STAR INDUSTRIES INC. 306 PASADENA AVE., SO. PASADENA, CA 91030	PROD CODE 844 CODE M
	SIGNATURE DRAWN BY <i>TWYL</i>	DATE 1/16/02		
MATERIAL:	P. E.		SIZE CODE IDENT NO. DRAWING NO. <b>B 98278</b> 095-0000-0462	SCALE: NONE SHEET 1 OF 1
FINISH:	THIS DOCUMENT IS THE PROPERTY OF MICRODOT CONNECTORS, A DIVISION OF UNI-STAR INDUSTRIES INC. USE OF THIS DOCUMENT OR ANY PART THEREOF IS STRICTLY FORBIDDEN WITHOUT THE EXPRESS WRITTEN PERMISSION OF MICRODOT CONNECTORS, A DIVISION OF UNI-STAR INDUSTRIES INC.			