

# **NB7L72MMNGEVB**

## **Assembly and Test Manual**

For more detailed information on the QFN16 evaluation board, see the QFN16EVB application note.

# NB7L72MMNGEVB Assembly

**Table 1.** Configuration for Device: **NB7L72M**

	J1	J2	J3	J4	J5	J6	J7	J8	J9	J10	J11	J12	J13	J14	J15	J16
Device Pin #	1	2	3	4	5	6	7	8	9	10	11	12	13	14	15	16
SMA Connector	Yes	Yes	Yes	Yes	Yes	Yes	No	No	Yes	Yes	Yes	Yes	No	No	Yes	Yes
Wire	No	No	No	No	No	No	GND	VCC	No	No	No	No	VCC	GND	No	No

Note: DUTGND / VEE = Exposed Pad and must be tied to DUTGND / VEE

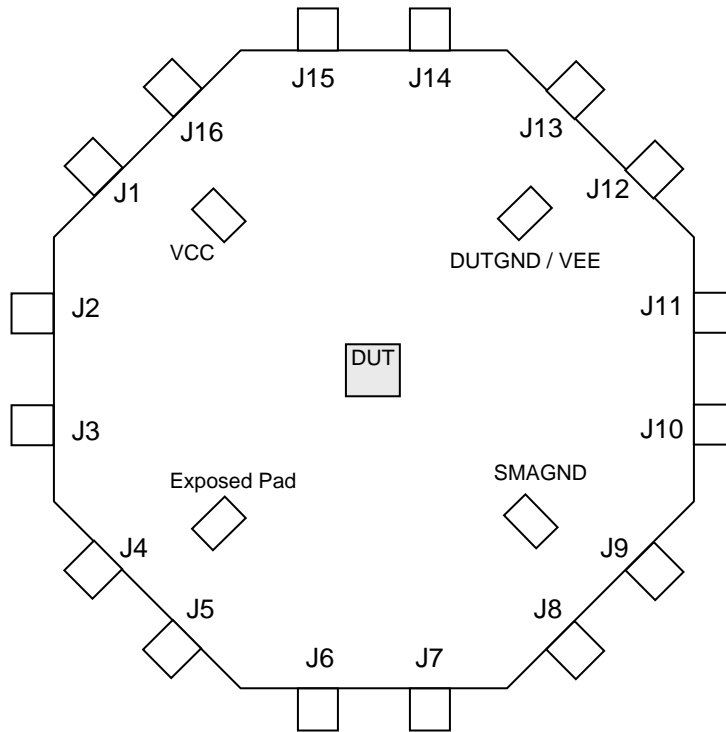

**Top View**

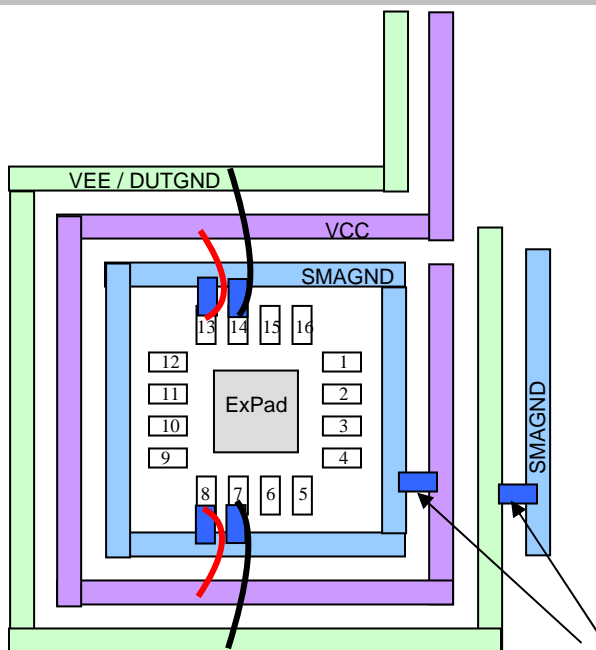

**Bottom View**

**Polarity of 22uF:**

+ C4 - + C2 -

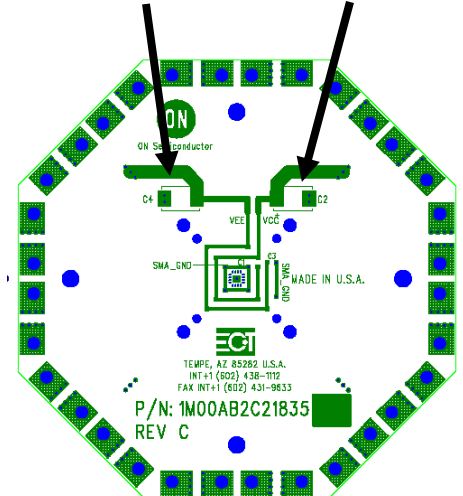

Install 0.1uF Decoupling Capacitors here and at package pins

**Table 2. Bill of Materials**

<b>Components</b>	<b>Manufacturer</b>	<b>Description</b>	<b>Part Number</b>	<b>QTY</b>	<b>Web Site</b>
SMA Connector	Rosenberger	SMA Connector, Side Launch, Gold Plated	32K243-40ME3	12	<a href="http://www.rosenberger.de">http://www.rosenberger.de</a> <a href="http://www.rosenbergerna.com">http://www.rosenbergerna.com</a>
Surface Mount Test Points	Keystone*	SMT Miniature Test Point	5015	4	<a href="http://www.keyelco.com">http://www.keyelco.com</a>
Chip Capacitor	AVC Corporation*	0603 0.01 $\mu$ F $\pm$ 10% 0603 0.1 $\mu$ F $\pm$ 10%	06035C103KAT2A 0603C104KAT2A	na 6	<a href="http://www.avxcorp.com">http://www.avxcorp.com</a>
Chip Resistor	Panasonic*	0402 50 $\Omega$ $\pm$ 1% Precision Thick Film Chip Resistor	ERJ-2RKF49R9X	na	<a href="http://www.panasonic.com">http://www.panasonic.com</a>
Evaluation Board	ON Semiconductor	QFN-16 Evaluation Board	QFN16EVB	1	<a href="http://www.onsemi.com">http://www.onsemi.com</a>
Device Samples	ON Semiconductor	QFN 16 Package Device	NB7L72MMNG	1	<a href="http://www.onsemi.com">http://www.onsemi.com</a>

\*Components are available through most distributors, i.e. [www.newark.com](http://www.newark.com), [www.Digikey.com](http://www.Digikey.com)

# NB7L72MMNGEVB Test

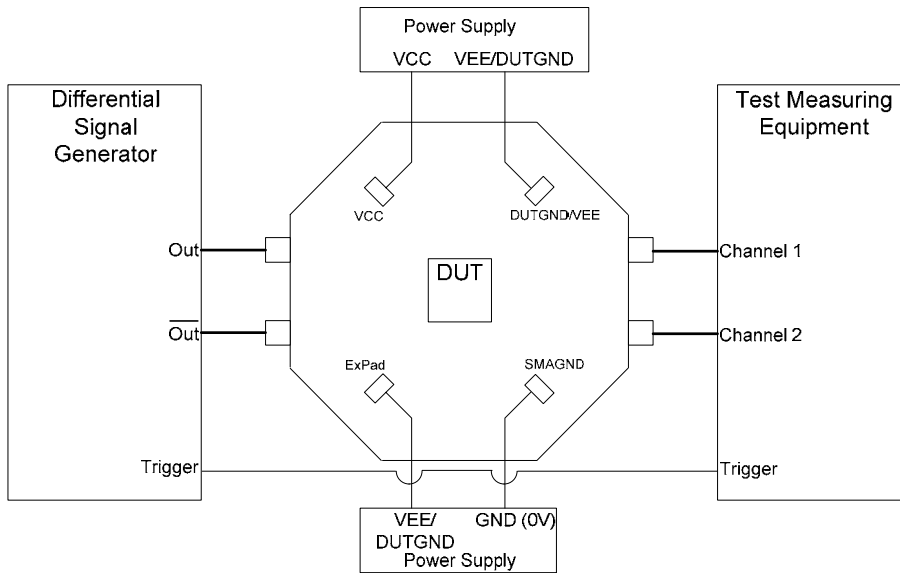

## Basic Lab Setup (typical)

1. Connect the appropriate power supplies to VCC, VEE/DUTGND, SMAGND, and ExPad (See Table 2.).
  2. Connect a signal generator to the input SMA connectors. Setup input signal according to the device data sheet.
  3. Connect a test measurement device to the device's output SMA connectors.
- NOTE: The test measurement device must contain 50-Ω termination.

**Table 3. Power Supply Levels**

Outputs	Power Supply	V <sub>CC</sub>	V <sub>EE</sub> / DUTGND	SMAGND	ExPad (typ.)
CML	2.5V	0.0V	-2.5V	0.0V	VEE / DUTGND
CML	3.3V	0.0V	-3.3V	0.0V	VEE / DUTGND

**Table 3. NB7xxxM, CML Outputs “Split” Power Supply Configuration**

Device Pin Power Supply Connector	“Spilt” Power Supply
VCC	VCC = 0.0V
SMAGND	VTT = 0V
DUTGND	DUTGND = -2.5V or -3.3V

## “Split” or Dual Power Supply Connections

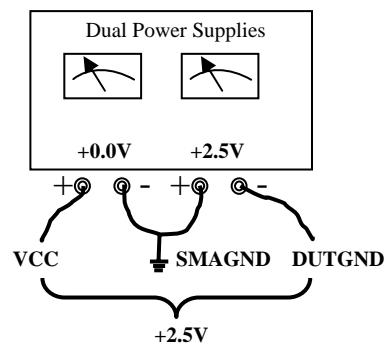

**Offset / “Split” Power Supply Configuration**