

THIS DRAWING IS UNPUBLISHED. RELEASED FOR PUBLICATION 20  
© COPYRIGHT 20 BY - ALL RIGHTS RESERVED.

REVISIONS

P	LTR	DESCRIPTION	DATE	DWN	APVD
A1		ECR-15-010494	20JUN2015	DW	CW
B		ECR-15-013292	24SEP2015	DL	CW
B1		ECR-15-017530	02DEC2015	GY	CW
B2		ECR-16-015492	12NOV2016	QY	CW

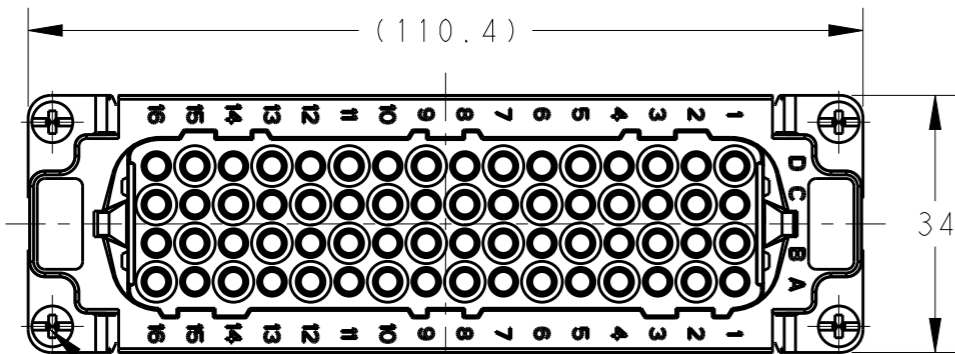

4X M3 SCREW RECOMMENDED  
TIGHTENING TORQUE 0.5Nm  
4X M3螺丝, 推荐锁紧力矩0.5Nm

M4 SCREW RECOMMENDED  
TIGHTENING TORQUE 1.2Nm  
M4 螺丝, 推荐锁紧力矩1.2Nm

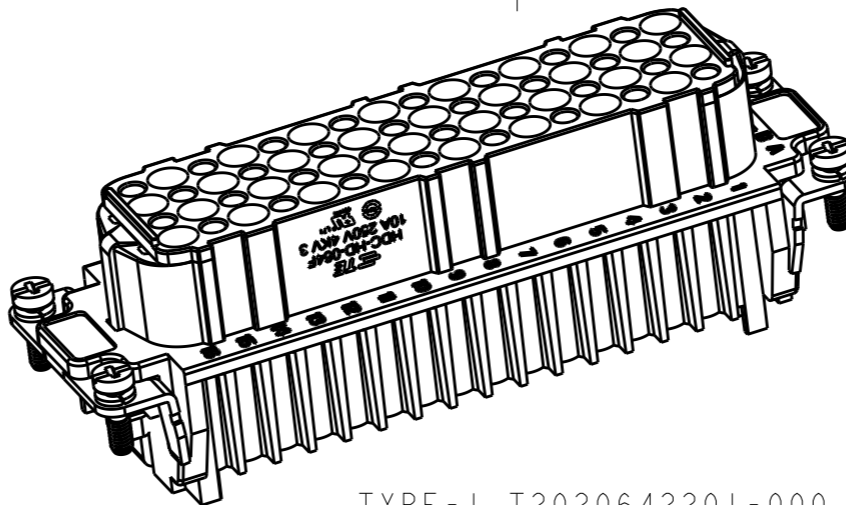
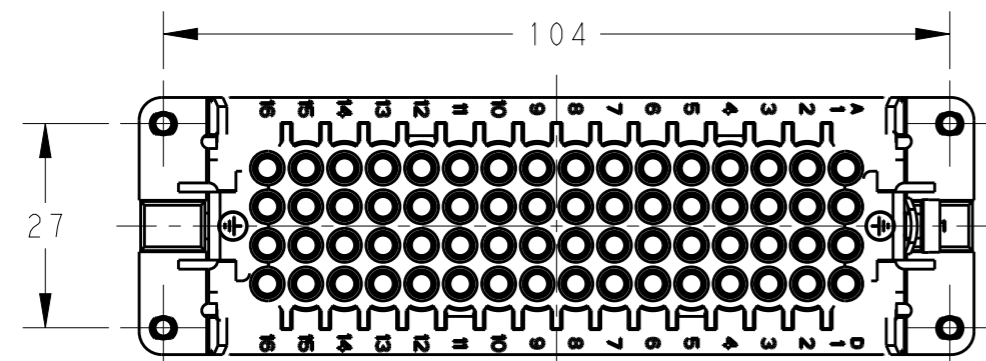
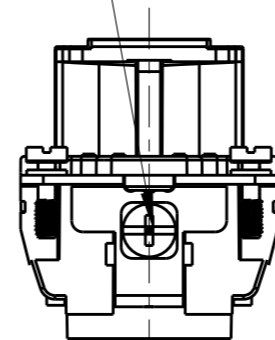

NOTES:  
 1. TECHNICAL CHARACTERISTICS:  
 INSULATION MATERIAL: PC  
 RATED VOLTAGE: 250 V  
 RATED CURRENT: 10 A  
 INSULATION RESISTANCE: >=400MΩ  
 RATED IMPULSE VOLTAGE: 4 KV  
 POLLUTION DEGREE: 3  
 FLAMMABILITY: UL94V-0  
 MATING CYCLES: 500 CYCLES  
 WIRE RANGE: 0.14-2.5 mm<sup>2</sup> (26-14 AWG)  
 CONTACT TYPE: CRIMP CONTACT  
 2. CONTACT NEED TO BE ORDERED SEPARATELY.  
 (ORDER No. REFER TO DRAWING:T20200X20XX000)

注释:  
 1. 技术参数:  
 绝缘材料: PC  
 额定电压: 250V  
 额定电流: 10A  
 绝缘电阻: >=400MΩ  
 额定脉冲电压: 4 KV  
 污染等级: 3  
 阻燃等级: UL94V-0  
 插拔次数: 500次  
 接线范围: 0.14-2.5 mm<sup>2</sup> (26-14 AWG)  
 接线类型: 冷压接  
 2. 端子需要单独订购.  
 (订货号参考图面: T20200X20XX000)

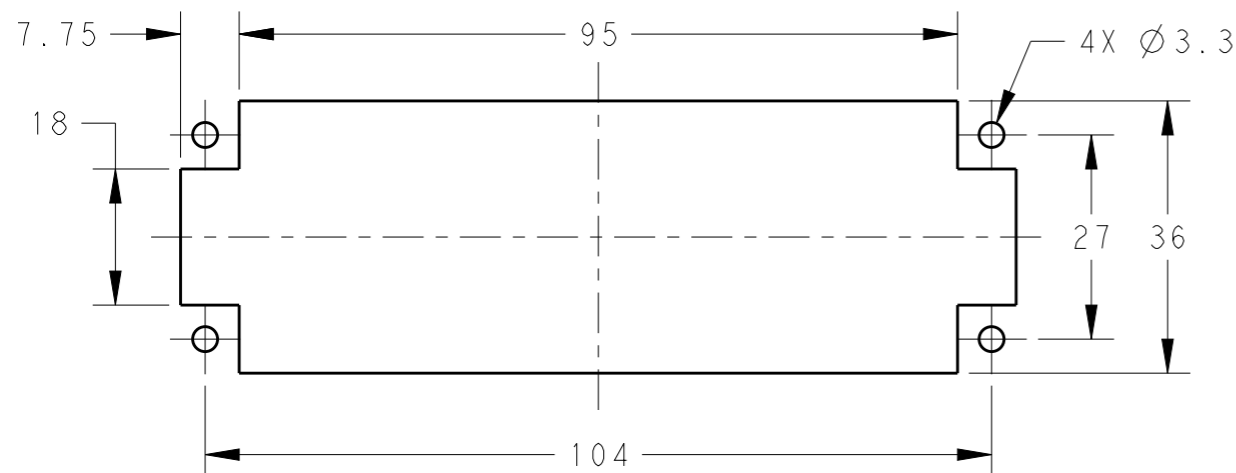

PANEL CUT FOR INSERTS FOR USE  
WITHOUT HOODS/ HOUSINGS  
不用防护外壳时芯件的安装开孔图

TYPE-1, T2020642201-000, TE LOGO  
类型-1, T2020642201-000, TE LOGO

TYPE-2, T2020642201-001, STAINLESS STEEL SCREW, TE LOGO  
类型-2, T2020642201-001, 不锈钢螺丝, TE LOGO

THIS DRAWING IS A CONTROLLED DOCUMENT.		DWN 300CT2014 David Wang	 TE Connectivity	
DIMENSIONS: mm		CHK 300CT2014 Chris Wang		
TOLERANCES UNLESS OTHERWISE SPECIFIED:		APVD 300CT2014 Xiang Xu	NAME HD-064-F	
0 PLC ±-		PRODUCT SPEC 108-137042	SIZE	
1 PLC ±-		APPLICATION SPEC 114-137042	CAGE CODE	
2 PLC ±-		WEIGHT	DRAWING NO	
3 PLC ±-		Customer Drawing	RESTRICTED TO	
4 PLC ±-			A300779	
ANGLES ±-			C-T2020642201000	
FINISH			SCALE 1:1	
			SHEET 1 OF 2	
			REV B2	

THIS DRAWING IS UNPUBLISHED.

RELEASED FOR PUBLICATION

20

© COPYRIGHT 20 BY -

ALL RIGHTS RESERVED.

REVISIONS

P	LTR	DESCRIPTION	DATE	DWN	APVD
-		SEE SHEET 1	-	-	-

NOTE:  
SEE SHEET 1  
注释:  
见页 1

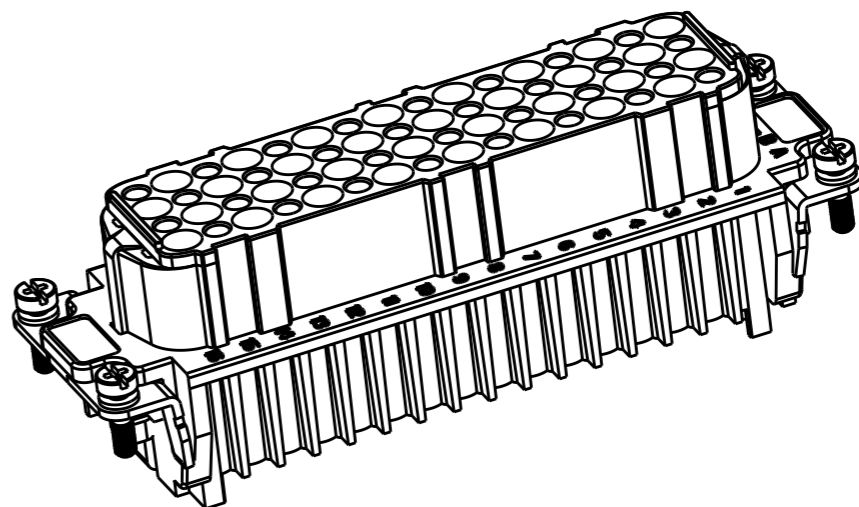
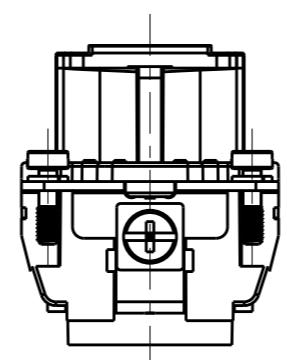
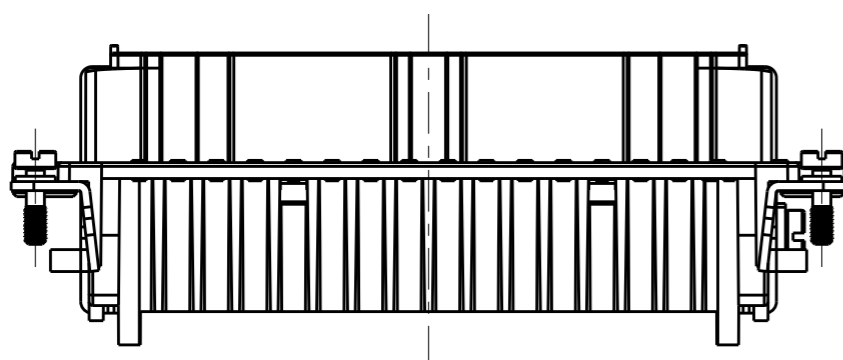
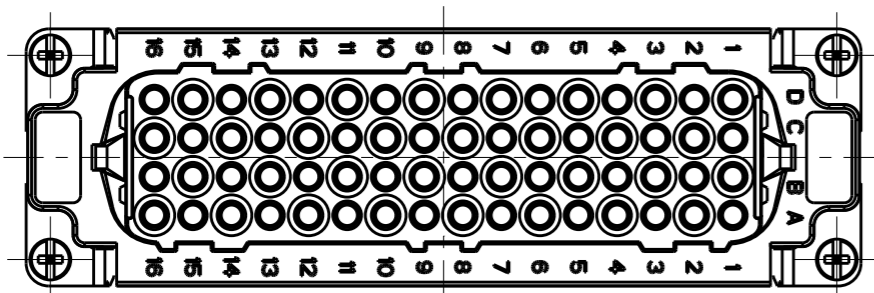

TYPE-3, T2020642201-002, STAINLESS STEEL SCREW, NO LOGO  
类型-3, T2020642201-002, 不锈钢螺丝, 无LOGO

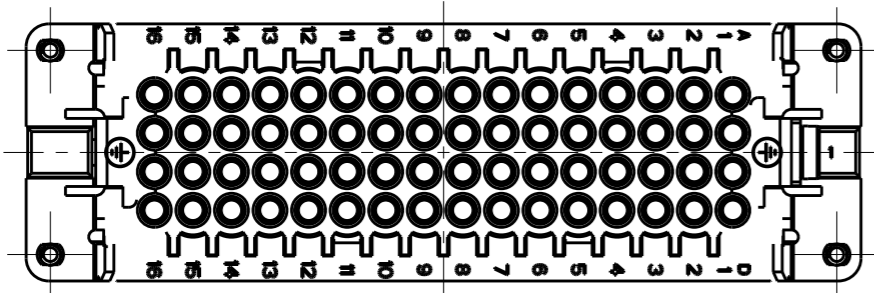

T2020642201-002	HD-064-F	HD-064 FEMALE INSERT, STAINLESS STEEL SCREW, NO LOGO HD-064 母插, 不锈钢螺丝, 无LOGO	TYPE-3 类型-3
T2020642201-001	HD-064-F	HD-064 FEMALE INSERT, STAINLESS STEEL SCREW HD-064 母插, 不锈钢螺丝	TYPE-2 类型-2
T2020642201-000	HD-064-F	HD-064 FEMALE INSERT HD-064 母插	TYPE-1 类型-1
PART NUMBER 料号	PART DESCRIPTION 描述		TYPE 类型

ALL DIMENSIONS ARE SAME AS TYPE 1,  
EXCEPT THOSE DEFINED IN THIS TYPE.  
除了在本类型中定义的尺寸外, 其它尺寸同类型 1

THIS DRAWING IS A CONTROLLED DOCUMENT.		DWN 300CT2014 David Wang	 TE Connectivity	
DIMENSIONS: mm		CHK 300CT2014 Chris Wang		
TOLERANCES UNLESS OTHERWISE SPECIFIED:		APVD 300CT2014 Xiang Xu	NAME HD-064-F	
0 PLC ±- 1 PLC ±- 2 PLC ±- 3 PLC ±- 4 PLC ±- ANGLES ±-		PRODUCT SPEC 108-137042	SIZE CAGE CODE DRAWING NO RESTRICTED TO	
MATERIAL		APPLICATION SPEC 114-137042	A300779 © T2020642201000	
FINISH		WEIGHT	SCALE 1:1 SHEET 2 OF 2 REV B2	
		Customer Drawing		