

Tous droits strictement reserves. Reproduction ou communication a des tiers interdite sous quelque forme que ce soit sans autorisation ecrite du proprietaire. Propriete de c FCI. Droits de reproduction FCI.

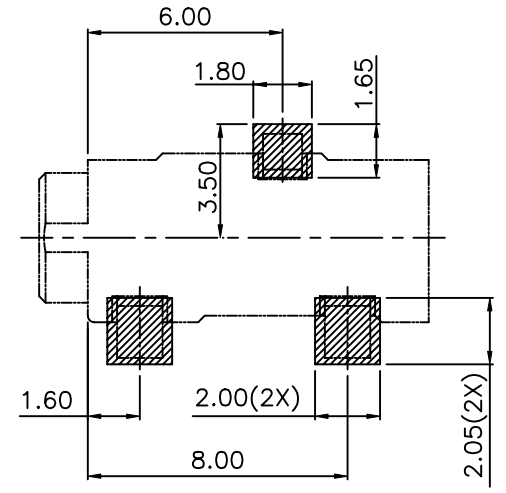

All rights strictly reserved. Reproduction or issue to third parties in any form whatever is not permitted without written authority from the proprietor. Property of Fci. Copyright FCI.

PART NUMBER  
10103332-AXPLF

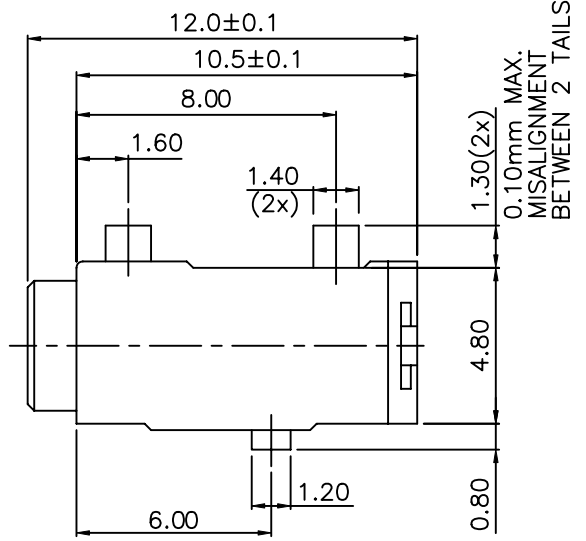

RECOMMENDED PCB LAYOUT  
GENERAL TOLERANCE ±0.05mm(BOTTOM VIEW)

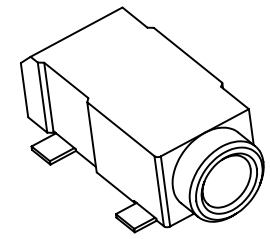
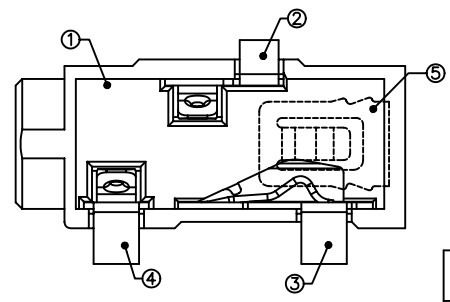
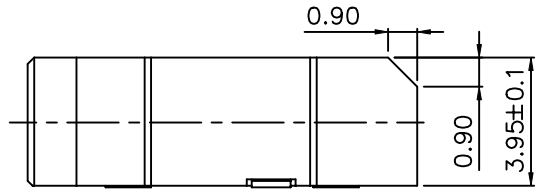
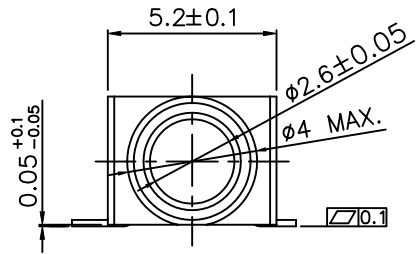

mat'l. code				tolerances unless otherwise specified				CUSTOMER COPY		FCI	
ltr	ecn no	dr	date	linear	.X ±0.30		projection		title		
A	T10-0044	WL	03/09/10		.XX ±0.20		MM		Ø2.5 PHONE JACK		
B	T10-0087	WL	06/29/10		.XXX ±0.10		scale		product family		
C	T10-0133	WL	08/12/10	angles	±2°		A4		size   dwg no		
				dr	WENDY CHEN	07/30/09			code		
				enr	WENDY CHEN	07/30/09			TWN		
				chr	GARY HSIEH	07/30/09			sheet		
				appd	JOSEPH HSIA	07/30/09			1 of 2		
sheet	revision	C	C								
index	sheet	1	2								



NOTES :

1. MATERIALS :
  - a. ITEM 1: HOUSING : THERMOPLASTIC UL94 V-0, COLOR; BLACK.
  - b. ITEM 2,3,4 : CONTACT : COPPER ALLOY.
  - c. ITEM 5 : SPRING : STAINLESS STEEL.
2. PLATING :  
CONTACT AND SOLDER AREA: SELECTIVE GOLD PLATED OVERALL,  
AND 50u" MIN. NICKEL UNDER PLATED.
3. PRODUCT SPECIFICATION: GS-12-637.
4. PACKING SPECIFICATION: GS-14-1442.
5. THIS PRODUCT MEETS THE EUROPEAN UNION DIRECTIVE AS DESCRIBED IN GS-22-008.
6. THE HOUSING WILL WITHSTAND EXPOSURE TO 260°C PEAK TEMPERATURE FOR 10 SECONDS IN A CONVECTION, IR OR VAPER PHASE REFLOW OVEN.
7. PART NUMBER DESCRIPTION:

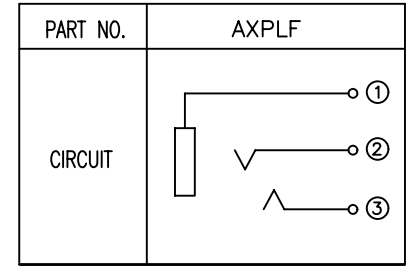
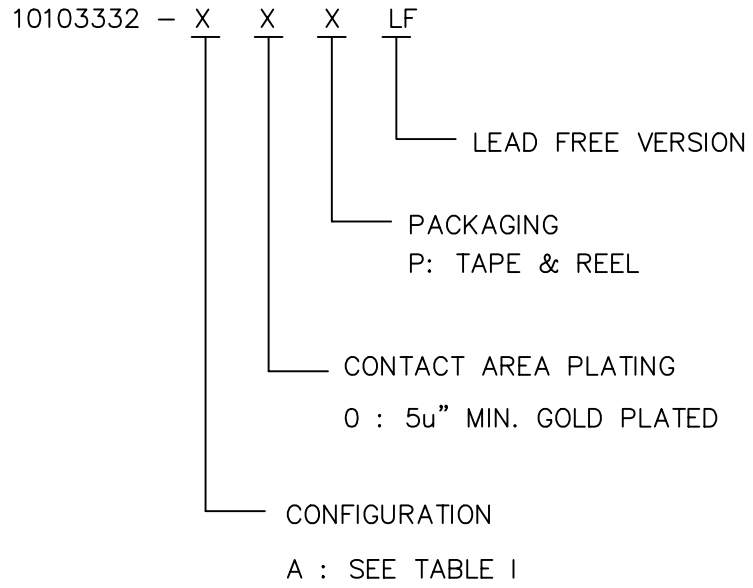

TABLE I

mat'l. code				tolerances unless otherwise specified				CUSTOMER COPY		FCI		www.fciconnect.com		
ltr	ecn no	dr	date	linear	.X ±0.30				projection	title				
C					.XX ±0.20						ø2.5 PHONE JACK			
					angles	.XXX ±0.10					product family		code	
				dr		WENDY CHEN	07/30/09	MM		size		TWN		
				enr	WENDY CHEN	07/30/09	← MM →		dwg no		sheet			
				chr	GARY HSIEH	07/30/09	scale		A4		2 of			
				appd	JOSEPH HSIA	07/30/09			10103332					
sheet index	revision sheet													