

REV.	DESCRIPTION/ECO NO.	DATE
	RELEASED	10/85
A	CHNG. PART NO. DNW10 TO DQ445	10/86
B	CHNG. PART # DQ445 TO 445	1/89
C	CORR.DIMS ON P.C.PATTERN	12/89
D	CHNG. PART # 445 TO DNW21	11/90
	ADD LAMP LIST	
E	DIM. 1.2 CHNG. TO REF.	6/95
G	DRAW. CONVERTED TO CAD-DELETE LAMPS DW26, DW45, DW48, DW40	1/18/00
H	CONTACT SPACING 1.1 REF.	10/16/00

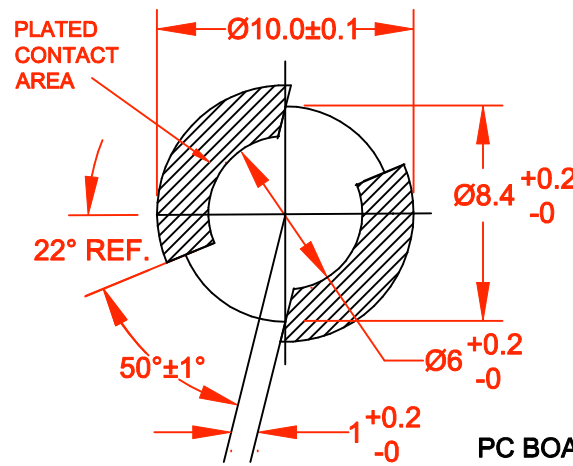

PC BOARD PUNCH PATTERN

(NO TREATMENT, SUCH AS APPLICATION OF FLUX, SHALL BE DONE.)

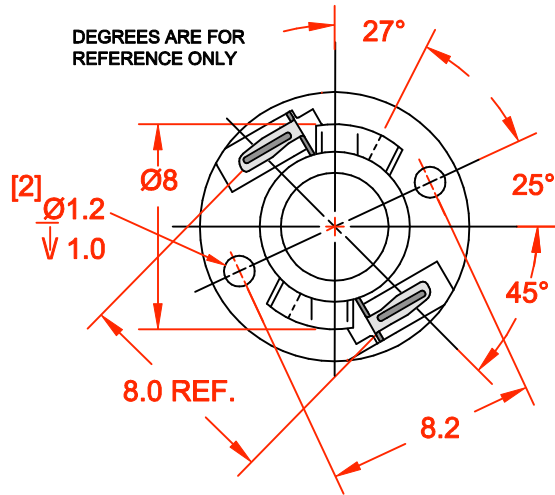
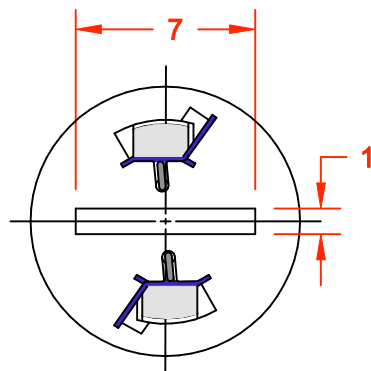
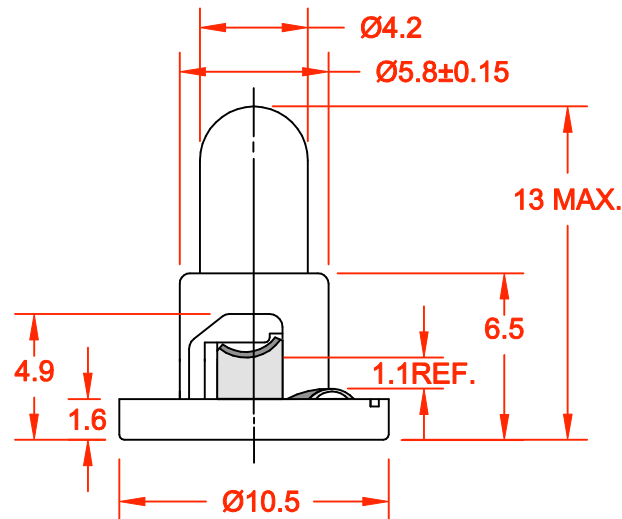

JKL LAMP NUMBER	VOLTS RATED	AMPS ±10%	*MSCP ±25%	*LUMENS ±25%	AVERAGE LIFE HRS.	FILAMENT TYPE
DNW21-583	5.0	.060	.050	0.63	100,000	C-2R
DNW21-515	5.0	.115	.150	1.89	40,000	C-2R
DNW21-634	6.0	.200	.630	7.92	1,000	C-2R
DNW21-DW50	8.0	.050	.095	1.19	10,000	C-2V
DNW21-DW44	12.0	.040	.090	1.13	10,000	C-2V
DNW21-DW07	14.0	.080	.300	3.77	15,000	C-2F
DNW21-DW10	14.0	.100	.500	6.29	10,000	C-2F
DNW21-8627	28.0	.040	.340	4.27	4,000	C-2F

*LAMP RATING ONLY WITHOUT BASE

<p>METRIC THIRD ANGLE PROJECTION</p>	<p>DIMENSIONS ARE IN MILLIMETERS TOLERANCE UNLESS OTHERWISE SPECIFIED 1 PL +/- 0.2 2 PL +/- 0.20 ANGLE +/- 0</p>	<p>JKL COMPONENTS CORPORATION</p>			
		<p>TITLE T-1 1/4 DOUBLE CONTACT NEO-WEDGE BASE WITH MULTIPLE LAMP LISTING</p>			
<p>DRAWN BY L. WENGSTROM</p>	<p>APPVD BY JK</p>	<p>DATE 10/16/00</p>	<p>SIZE A</p>	<p>FSCM NO. 55335</p>	<p>DRAWING NO. DNW21-MULTI</p>
<p>- CAD DRAWING - MANUAL REVISIONS NOT PERMITTED</p>			<p>SCALE NONE</p>	<p>RELEASED DATE 10/85</p>	<p>REVISION DATE 10/16/00</p>
				<p>REV. NO. H</p>	<p>SHEET 1 OF 1</p>