

PART NAME: KNOB SCALE: 1:1 DATE: 5/14/09 DR. BY JAM

DAVIES MOLDING COMPANY
CAROL STREAM, ILLINOIS 60188

P/N	1506-D
MOLD #	1505/1506/2813
CAVITY	1506
CORE	1506
PIN	BP1506-H

THIS DRAWING IS THE PROPERTY OF DAVIES MOLDING COMPANY, IS SUBMITTED SOLELY AS A DESIGN OR ENGINEERING PROJECT. WE ACCEPT NO RESPONSIBILITY WHATSOEVER FOR THE PRACTICAL APPLICATION OF THE PIECES MADE TO THIS DESIGN.

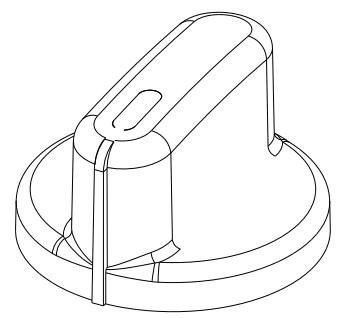
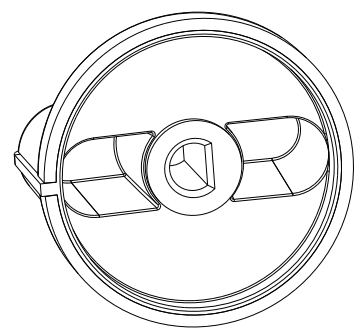
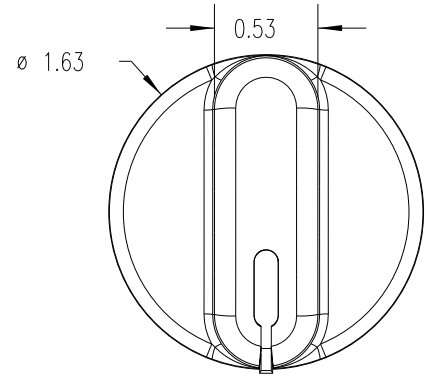

(A)

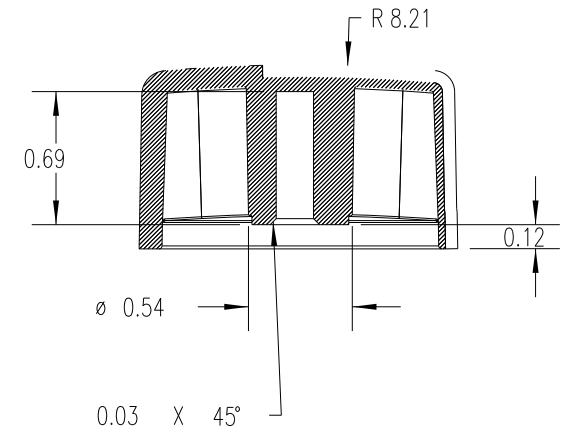
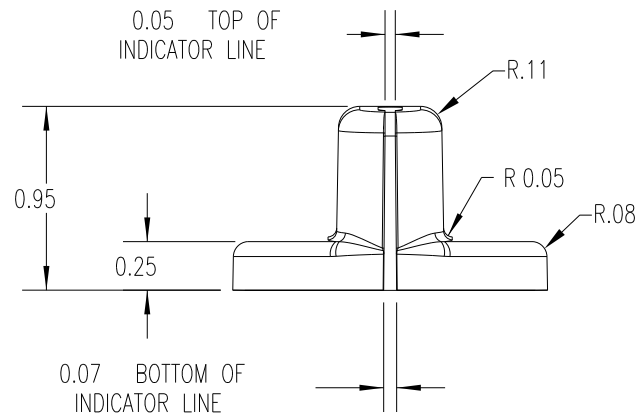

0.07 BOTTOM OF INDICATOR LINE

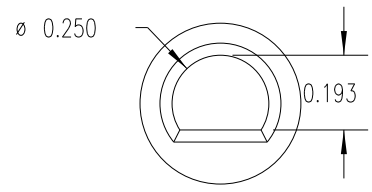

DETAIL D
SCALE 2 : 1

SECTION A-A

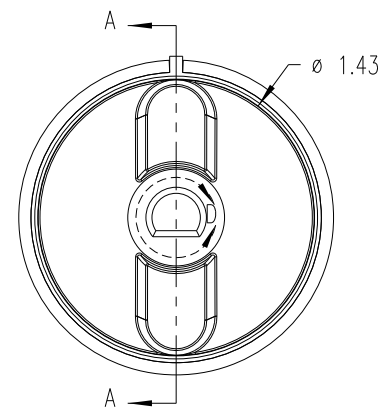

SUBSTRATE MATERIAL: 33% GLASS FILLED NYLON (CL5)
COLOR: WHITE (SWNYGFHW)
OVERMOLD MATERIAL: TPE (TPE1)
COLOR: GRAY (MC83894A)

TOLERANCES: UNLESS OTHERWISE SPECIFIED	DO NOT SCALE DRAWING			
DECIMALS: X.XXX ± .005 X.XX ± .015	MM: X.XX ± 0.15MM X.X ± 0.4MM	A	MOLD # WAS 1506	JAM 12/14/09
FRACTIONS ± 1/64	ANG. ± 1°	-	WAS SK1506-10	JAM 5/14/09
CHANGES				