

PART NAME: KNOB SCALE: 1:1 DATE: 11/20/85 DR. BY HD

THIS DRAWING IS THE PROPERTY OF DAVIES MOLDING COMPANY, IS SUBMITTED SOLELY AS A DESIGN OR ENGINEERING PROJECT. WE ACCEPT NO RESPONSIBILITY WHATSOEVER FOR THE PRACTICAL APPLICATION OF THE PIECES MADE TO THIS DESIGN.



P/N 3087-A

M NO. # 24 (PRESS 751)

CAVITY	3087
CORE	3087
CAVITY PLUG	3087-A
SLEEVE	3087-A
CORE PIN	3087-A-1
PIN	3087-C
INSERT	11407

ROTARY SET-UP

M NO. # 117

CAVITY	3087 (8 CAV. BLOCK)
CORE	3087 (8 CORE BLOCK)
TOP PIN	3087-S
SLEEVE	3087-G
BOTTOM PIN	3087-A
INSERT	11407

T.O.# 4056

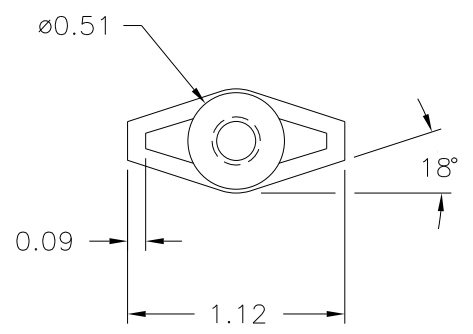
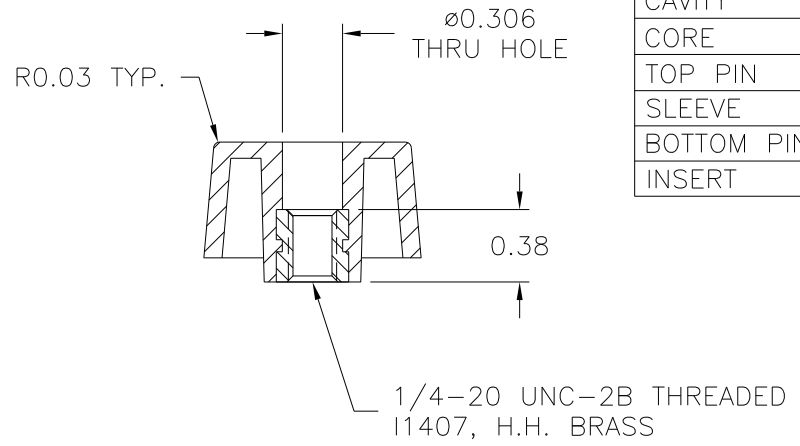
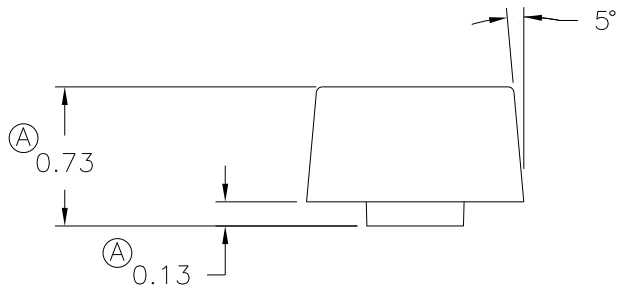
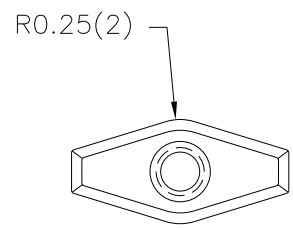

(D) MATERIAL: NYLON 6/6 (ZY2), (ZY6)
OR ENGINEERING APPROVED EQUIVALENT
COLOR: BLACK

D	WAS CLC, ADDED ZY6	JAM	6/25/12
C	ADDED MAT. CODE	DS	1/8/07
-	CORRECTED TOOLING BOX AND PART APPEARANCE	TS	6/26/02
B	ADDED SLEEVE 3087-A	ST	7/28/2000
-	RE-DID REDRAW	TL	11/11/99
-	CAD REDRAW	HD	4/10/96
A	O.A. WAS 3/4 & WAS 5/32	HD	6/6/95

TOLERANCES: UNLESS OTHERWISE SPECIFIED	DO NOT SCALE DRAWING
DECIMALS: X.XXX ± .005 X.XX ± .015	MM: X.XX ± 0.15MM X.X ± 0.4MM
FRACTIONS ± 1/64	ANG. ± 1°

CHANGES