

REL	WAS	DATE	BY	APPD
38536-206				
A1 45524-233	ADD & REL -XX8 & -XX9 FINISH	1-4-65	WANNI	
A2 52481-4	REV SLEEVE COL	1-5-71	Randall	Hage
A3 52524-511	REL -8	4-29-71	CARE	Harris
A4 55508-133	ADD & REL -XXG NOTE #2	4-17-74	GOULD	
B 71022-1	(CLII) CHG THD COL ECN:	12-6-79	W BAKER	Bowen
C 23815	(CLII) REV L COL	2-12-90	JED	Shopley
D 83722	(CLII) ADDED & REL -XXU	9-24-97	JED	SEP
E 85553	ADD + REL -XXY	10/9/97	RLB	MB
F 85976	ADD + REL -XXX	11/4/99	DM	

ASSEMBLY NUMBER	DETAILS				G MAX	L MAX	BB DIA +.000 -.011	CC DIA +.011 -.010	Y THREAD REF SIZE CLASS 2B	W +.005 -.015	SCREW SIZE
	NUT	SLEEVE	CLAMP								
10-330952-8	10-330953-8	10-454954-8	10-130511-8		.775	1.190	.250	.540	.4375-28UNEF	.215	6-32NC
-10	-10	-10	-10		.837		.312	.665	.5625-24UNEF		
-12	-12	-12	-12		.963		.438	.793	.6875-24UNEF		
-14	-14	-14	-14		1.087		.562	.910	.8125-20UNEF		
-16	-16	-16	-16		1.150	1.292	.625	1.037	.9375-20UNEF		
-18	-18	-18	-18		1.400		.750	1.155	1.0625-18UNEF		8-32NC
-20	-20	-20	-18		1.400	1.332	.750	1.281	1.1875-18UNEF	.250	
-22	-22	-22	-20		1.587		.938	1.408	1.3125-18UNEF		
-24	-24	-24	-22		1.681		1.000	1.533	1.4375-18UNEF		

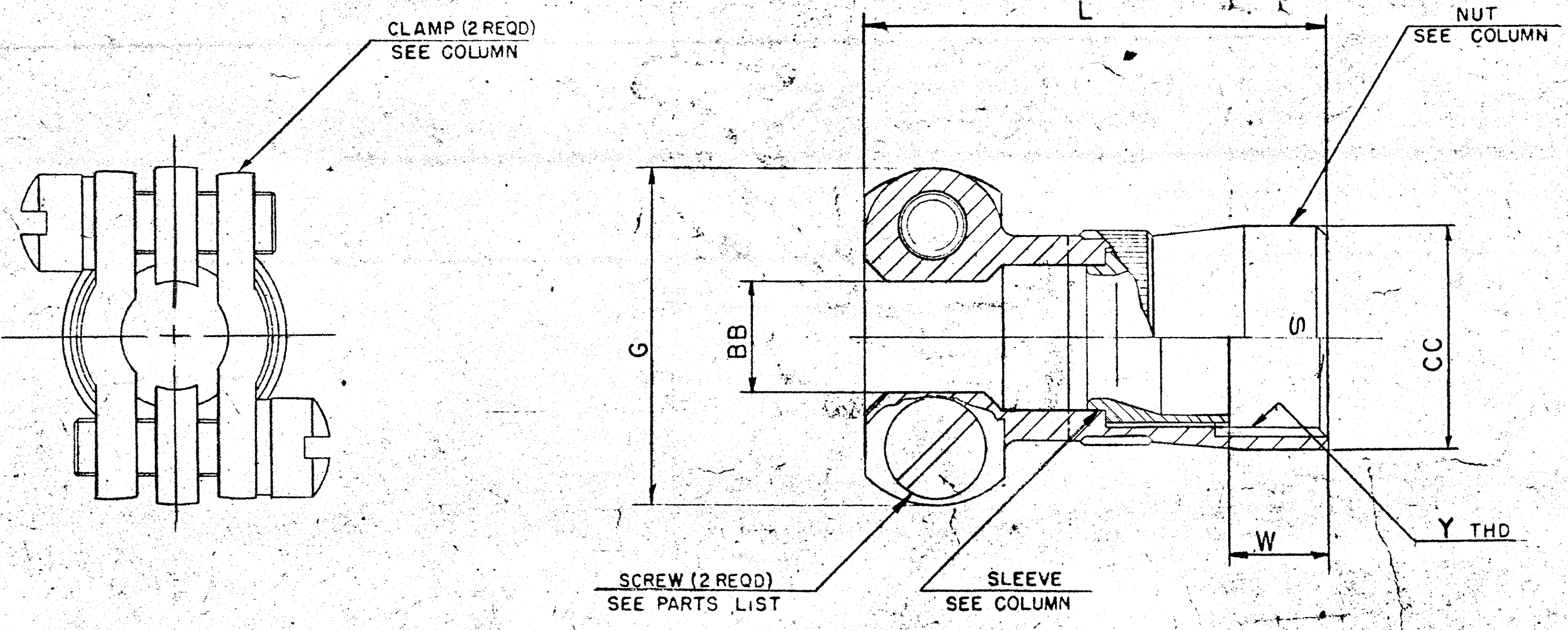

10-330952

2. FOR RELEASE STATUS OF DESIRED PART, SEE SEPARATE PARTS LIST.
 1. TO COMPLETE ASSEMBLY NO. AND DETAIL NO., ADD APPLICABLE LAST DIGIT SUFFIX NO. FOR DESIRED FINISH.

- | | |
|---------------------------------------|-------------|
| CHROMATE TREAT | SUFFIX -XX0 |
| BRIGHT CADMIUM PLATE | SUFFIX -XX1 |
| BLACK ANODIZE | SUFFIX -XX2 |
| CADMIUM PLATE OLIVE DRAB | SUFFIX -XX3 |
| GREY ANODIZE | SUFFIX -XX4 |
| ANODIC COATING | SUFFIX -XX5 |
| CADMIUM PLATE NICKEL BASE PLATE | SUFFIX -XX7 |
| BRIGHT NICKEL | SUFFIX -XX8 |
| OLIVE DRAB CADMIUM, NICKEL BASE PLATE | SUFFIX -XX9 |
| NICKEL ALLOY PLATE | SUFFIX -XXG |
| NOTE: GREEN ZINC ALLOY PLATE | SUFFIX -XXU |

BLACK ZINC ALLOY CONDUCTIVE PLATE SUFFIX -XXX
 BLACK ZINC ALLOY PLATE SUFFIX -XXY

USE OF THIS DOCUMENT IS UNLIMITED. DOCUMENTS REFERENCED HEREON CONTAIN LIMITED RIGHTS DATA.

MATERIAL SPEC	PROCESS SPEC	SCINTILLA MAGNETO DIVISION RAYOVATION CORPORATION MILWAUKEE, WIS.	
HEAT TREAT SPEC	FINISH SPEC	TITLE CLAMP, CABLE STRAIN RELIEF ELECTRICAL CONNECTOR TYPE PT - SE, ASSEMBLY OF	
DATE 3-22-62		BY J.F. [Signature]	CHKD [Signature]
DRAWN BY [Signature]		SCALE NONE	QTY 10-189010
PART NO. 10-330952		SEE ARTS LIST	

SCANNED