



Description

The XR33053 is a high performance TIA-485/TIA-422 device designed for improved performance in noisy industrial environments and increased tolerance to system faults.

The analog bus pins can withstand direct shorts up to ±60V and are protected against ESD events up to ±15kV HBM. An extended ±25V common mode operating range allows for more reliable operation in noisy environments.

The receiver includes full fail-safe circuitry, guaranteeing a logic-high receiver output when the receiver inputs are open, shorted or undriven. The XR33053 receiver input impedance is at least 120kΩ (1/10 unit load), allowing more than 320 devices on the bus.

The driver is protected by short circuit detection as well as thermal shutdown and maintains high impedance in shutdown or when powered off.

The DE and \overline{RE} pins include hot swap circuitry to prevent false transitions on the bus during powerup or live insertion and can enter a 1nA low current shutdown mode for extreme power savings.

FEATURES

- 3.0V to 5.5V operation
- ±60V fault tolerance on analog bus pins
- Extended ±25V common mode operation
- Robust ESD protection:
 - ±15kV HBM (bus pins)
 - ±4kV HBM (non-bus pins)
- Enhanced receiver fail-safe protection for open, shorted or terminated but idle data lines
- Hot swap glitch protection on DE and \overline{RE} pins
- Driver short circuit current limit and thermal shutdown for overload protection
- Reduced unit loads allows up to 320 devices on bus
- Industry standard 14-pin NSOIC package
- -40°C to 85°C ambient operating temperature range

APPLICATIONS

- Industrial control networks
- HVAC networks
- Building and process automation
- Remote utility meter reading
- Energy monitoring and control
- Long or unterminated transmission lines

Typical Application

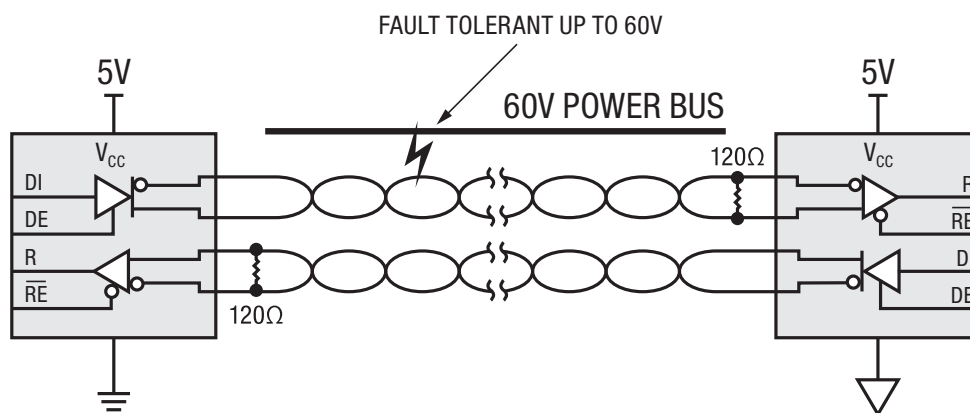

Figure 1. Typical Application

Absolute Maximum Ratings

These are stress ratings only and functional operation of the device at these ratings or any other above those indicated in the operation sections to the specifications below is not implied. Exposure to absolute maximum rating conditions for extended periods of time may affect reliability and cause permanent damage to the device.

V_{CC}	-0.3V to 7.0V
Input voltage at control and driver input (DE and DI)	-0.3V to 7.0V
Input voltage at control and driver input (\overline{RE})	-0.3V to ($V_{CC} + 0.3V$)
Receiver output voltage (RO)	-0.3V to ($V_{CC} + 0.3V$)
Driver output voltage (A, B, Y and Z)	$\pm 60V$
Receiver input voltage (A and B, full duplex)	$\pm 60V$
Transient voltage pulse, through 100 Ω (Figure 6)	$\pm 100V$
Driver output current	$\pm 250mA$
Storage temperature range	-65°C to 150°C
Lead temperature (soldering, 10s)	300°C
Package power dissipation, 14-pin NSOIC $\theta_{JA} = 86^{\circ}C/W$	Maximum junction temperature = 150°C

CAUTION:

ESD-sensitive (electrostatic discharge) device. Permanent damage may occur on unconnected devices subject to high energy electrostatic fields. Unused devices must be stored in conductive foam or shunts. Personnel should be properly grounded prior to handling this device. The protective foam should be discharged to the destination socket before devices are removed.

Pin Configuration

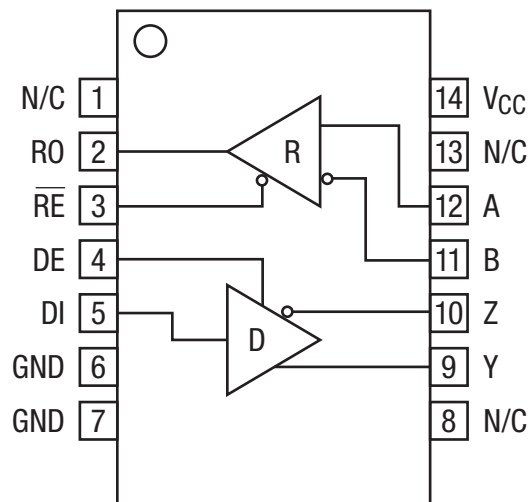

Pin Functions

Full Duplex	Pin Name	Type	Pin Function
XR33053			
Pin Number			
2	RO	Out	Receiver output. When \overline{RE} is low and if $(A-B) \geq 200\text{mV}$, RO is high. If $(A-B) \leq -200\text{mV}$, RO is low. If inputs are left floating, shorted together or terminated and undriven for more than $2\mu\text{s}$, the output is high.
3	\overline{RE}	In	Receiver output enable (hot swap). When \overline{RE} is low, RO is enabled. When \overline{RE} is high, RO is high impedance, \overline{RE} should be high and DE should be low to enter shutdown mode.
4	DE	In	Driver output enable (hot swap). When DE is high, outputs are enabled. When DE is low, outputs are high impedance, DE should be low and \overline{RE} should be high to enter shutdown mode.
5	DI	In	Driver input. With DE high, a low level on DI forces non-inverting output low and inverting output high. Similarly, a high level on DI forces non-inverting output high and inverting output low.
6, 7	GND	Power	Ground.
14	V _{CC}	Power	3.0V to 5.5V power supply input, bypass to ground with $0.1\mu\text{F}$ capacitor.
12	A	In	Non-inverting receiver input.
11	B	In	Inverting receiver input.
9	Y	Out	Non-inverting driver output.
10	Z	Out	Inverting driver output.
1, 8, 13	N/C	-	Not connected.

Pin Functions

Transmitting				
Inputs			Outputs	
\overline{RE}	DE	DI	Y	Z
X	1	1	1	0
X	1	0	0	1
0	0	X	High-Z	
1	0	X	High-Z (shutdown)	

Receiving			
Inputs			Output
\overline{RE}	DE	$V_A - V_B$	RO
0	X	$\geq 200\text{mV}$	1
0	X	$\leq -200\text{mV}$	0
0	X	Open/shorted	1
1	1	X	High-Z
1	0	X	High-Z (shutdown)

Electrical Characteristics

Unless otherwise noted: $V_{CC} = 3.0V$ to $5.5V$, $T_A = T_{MIN}$ to T_{MAX} . Typical values are at $V_{CC} = 5.0V$, $T_A = 25^\circ C$.

Symbol	Parameter	Conditions	Min	Typ	Max	Units
Driver DC Characteristics						
V_{CC}	Supply voltage range		3.0		5.5	V
V_{OD}	Differential driver output, $4.5V \leq V_{CC} \leq 5.5V$	$R_L = 100\Omega$ (TIA-422), Figure 3	2		V_{CC}	V
		$R_L = 54\Omega$ (TIA-485), Figure 3	1.5		V_{CC}	V
		$-25V \leq V_{CM} \leq 25V$, Figure 4	1.5		V_{CC}	V
	Differential driver output, $3.0V \leq V_{CC} \leq 4.5V$	$R_L = 100\Omega$ (TIA-422), Figure 3	0.85		V_{CC}	V
$R_L = 54\Omega$ (TIA-485), Figure 3		0.65		V_{CC}	V	
ΔV_{OD}	Change in magnitude of differential output voltage, Note 1	$R_L = 100\Omega$ (TIA-422) or $R_L = 54\Omega$ (TIA-485), Figure 3			± 0.2	V
V_{CM}	Driver common-mode output voltage (steady state)		1		3	V
ΔV_{CM}	Change in magnitude of common-mode output voltage, Note 1					± 0.2
V_{IH}	Logic high input thresholds (DI, DE and \overline{RE})	$V_{CC} = 3.3V$	2.0			V
		$V_{CC} = 5.0V$	2.4			V
V_{IL}	Logic low input thresholds (DI, DE and \overline{RE})	Logic input low			0.8	V
V_{HYS}	Input hysteresis (DI, DE and \overline{RE})			100		mV
I_{IN}	Logic input current (DI, DE and \overline{RE})	$0V \leq V_{IN} \leq V_{CC}$, After first transition, Note 2			± 1	μA
I_{INHS}	Logic input current hot swap (DE and \overline{RE})	Until first transition, Note 2		100	± 200	μA
$I_{A, B}$	Input current (A and B)	$V_{CC} = 0V$ or $5.5V$, $V_{OUT} = 12V$, $DE = 0V$			100	μA
		$V_{CC} = 0V$ or $5.5V$, $V_{OUT} = -7V$, $DE = 0V$	-80			μA
I_{OL}	Output leakage (Y and Z) Full duplex, Note 2	$V_{OUT} = 12V$, $DE = 0V$, $V_{CC} = 0V$ or $5.5V$			100	μA
		$V_{OUT} = -7V$, $DE = 0V$, $V_{CC} = 0V$ or $5.5V$	-80			μA
I_{OSD}	Driver short-circuit output current	$-60V \leq V_{OUT} \leq 60V$ $DI = 0V$ or V_{CC} , Figure 5			± 250	μA

NOTES:

- Change in magnitude of differential output voltage and change in magnitude of common mode output voltage are the changes in output voltage when DI input changes state.
- The hot swap feature disables the DE and \overline{RE} inputs for the first $10\mu s$ after power is applied. Following this time period, these inputs are weakly pulled to their disabled state (low for DE, high for \overline{RE}) until the first transition, after which they become high impedance inputs.

Electrical Characteristics

Unless otherwise noted: $V_{CC} = 3.0V$ to $5.5V$, $T_A = T_{MIN}$ to T_{MAX} . Typical values are at $V_{CC} = 5.0V$, $T_A = 25^\circ C$.

Symbol	Parameter	Conditions	Min	Typ	Max	Units
Driver Thermal Characteristics						
T_{TS}	Thermal shutdown temperature	Junction temperature, Note 1		175		$^\circ C$
T_{TSH}	Thermal shutdown hysteresis	Note 1		15		$^\circ C$
Receiver DC Characteristics						
V_{STH}	Receiver differential input signal threshold voltage ($V_A - V_B$)	$-25V \leq V_{OUT} \leq 25V$		± 85	± 200	mV
ΔV_{STH}	Receiver differential input signal hysteresis			170		mV
V_{FSTH-}	Negative going receiver differential input fail-safe threshold voltage ($V_A - V_B$)	$-25V \leq V_{OUT} \leq 25V$	-200	-125	-40	mV
V_{FSTH+}	Positive going receiver differential input fail-safe threshold voltage ($V_A - V_B$)	$-25V \leq V_{OUT} \leq 25V$		-100	-10	mV
ΔV_{FSTH}	Receiver differential input fail-safe hysteresis			25		mV
V_{OH}	Receiver output high voltage (RO)	$I_{OUT} = -4mA$	$V_{CC} - 0.6$			V
V_{OL}	Receiver output low voltage (RO)	$I_{OUT} = 4mA$			0.4	V
I_{OZR}	High-Z receiver output current	$0V \leq V_{OUT} \leq V_{CC}$			± 1	μA
R_{IN}	RX input resistance	$-25V \leq V_{CM} \leq 25V$	120			k Ω
		$-25V \leq V_{CM} \leq 25V$	30			k Ω
I_{OSC}	RX output short-circuit current	$0V \leq V_{RO} \leq V_{CC}$			110	mA
Supply Current						
I_{CC}	Supply current	No load, $\overline{RE} = 0V$ or V_{CC} , $DE = V_{CC}$, $DI = 0V$ or V_{CC}			4	mA
I_{SHDN}	Supply current in shutdown mode	$\overline{RE} = V_{CC}$, $DE = 0V$		0.001	1	μA
ESD Protection						
	ESD protection for A, B, Y, and Z	Human body model		± 15		kV
	ESD protection for all other pins	Human body model		± 4		kV

NOTE:

1. This spec is guaranteed by design and bench characterization.

Driver AC Characteristics - XR33053 (1Mbps)

Unless otherwise noted: $V_{CC} = 3.0V$ to $5.5V$, $T_A = T_{MIN}$ to T_{MAX} . Typical values are at $V_{CC} = 5.0V$, $T_A = 25^\circ C$.

Symbol	Parameter	Conditions	Min	Typ	Max	Units
t_{DPLH}	Driver prop. delay (low to high)	$C_L = 50pF$, $R_L = 54\Omega$, Figure 7		150	500	ns
t_{DPHL}	Driver prop. delay (high to low)			150	500	ns
$ t_{DPLH} - t_{DPHL} $	Differential driver output skew			5	50	ns
t_{DR} , t_{DF}	Driver differential output rise or fall time			100	200	300
	Maximum data rate	$1/t_{UI}$, duty cycle 40% to 60%	1			Mbps
t_{DZH}	Driver enable to output high	$C_L = 50pF$, $R_L = 500\Omega$, Figure 8		1000	2500	ns
t_{DZL}	Driver enable to output low			1000	2500	ns
t_{DHZ}	Driver disable from output high				250	ns
t_{DLZ}	Driver disable from output low				250	ns
$t_{DZH(SHDN)}$	Driver enable from shutdown to output high	$C_L = 50pF$, $R_L = 500\Omega$, Figure 8		2500	4500	ns
$t_{DZL(SHDN)}$	Driver enable from shutdown to output low			2500	4500	ns
t_{SHDN}	Time to shutdown	Notes 1 and 2	50	200	600	ns

Receiver AC Characteristics - XR33053 (1Mbps)

Unless otherwise noted: $V_{CC} = 3.0V$ to $5.5V$, $T_A = T_{MIN}$ to T_{MAX} . Typical values are at $V_{CC} = 5.0V$, $T_A = 25^\circ C$.

Symbol	Parameter	Conditions	Min	Typ	Max	Units
t_{RPLH}	Receiver prop. delay (low to high)	$C_L = 15pF$, $V_{ID} = \pm 2V$, V_{ID} rise and fall times $< 15ns$, Figure 9			200	ns
t_{RPHL}	Receiver prop. delay (high to low)				200	ns
$ t_{RPLH} - t_{RPHL} $	Receiver propagation delay skew				30	ns
	Maximum data rate	$1/t_{UI}$, duty cycle 40% to 60%	1			Mbps
t_{RZH}	Receiver enable to output high	$C_L = 15pF$, $R_L = 1k\Omega$, Figure 10			50	ns
t_{RZL}	Receiver enable to output low				50	ns
t_{RHZ}	Receiver disable from output high				50	ns
t_{RLZ}	Receiver disable from output low				50	ns
$t_{RZH(SHDN)}$	Receiver enable from shutdown to output high	$C_L = 15pF$, $R_L = 1k\Omega$, Figure 10			3500	ns
$t_{RZL(SHDN)}$	Receiver enable from shutdown to output low				3500	ns
t_{SHDN}	Time to shutdown	Notes 1 and 2	50	200	600	ns

NOTES:

- The transceivers are put into shutdown by bringing \overline{RE} high and DE low simultaneously for at least 600ns. If the control inputs are in this state for less than 50ns, the device is guaranteed to not enter shutdown. If the enable inputs are held in this state for at least 600ns, the device is ensured to be in shutdown. Note that the receiver and driver enable times increase significantly when coming out of shutdown.
- This spec is guaranteed by design and bench characterization.

Applications Information

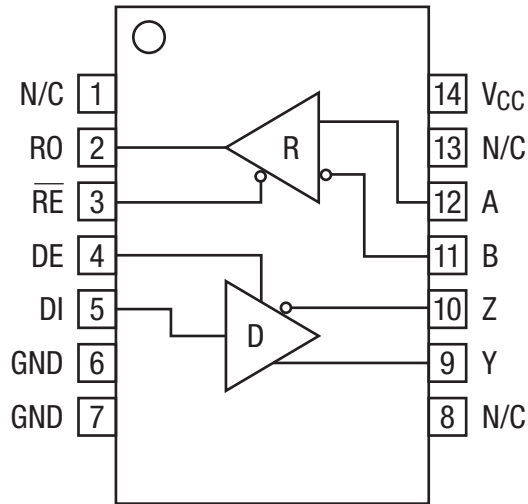

Figure 2. Full Duplex XR33053

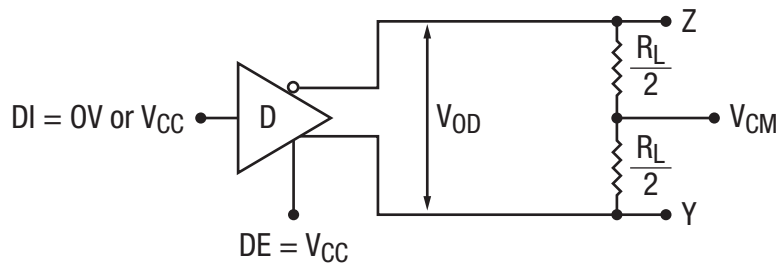

Figure 3. Differential Driver Output Voltage

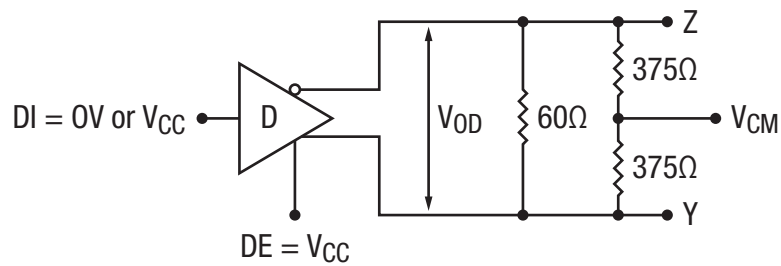

Figure 4. Differential Driver Output Voltage Over Common Mode

Applications Information

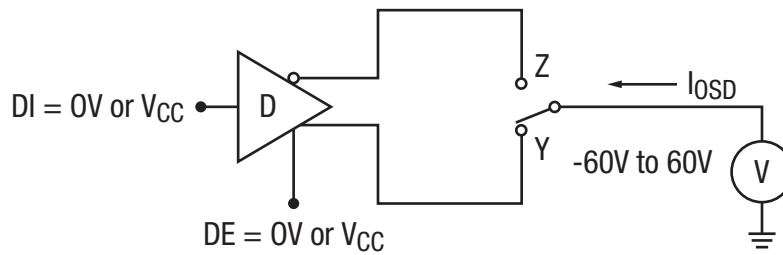

Figure 5. Driver Output Short Circuit Current

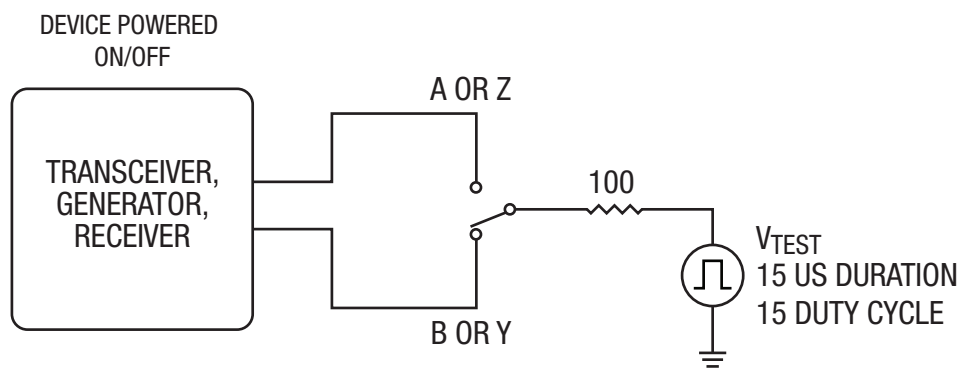

Figure 6. Transient Overvoltage Test Circuit

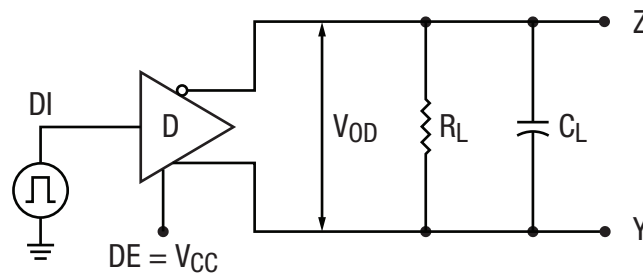
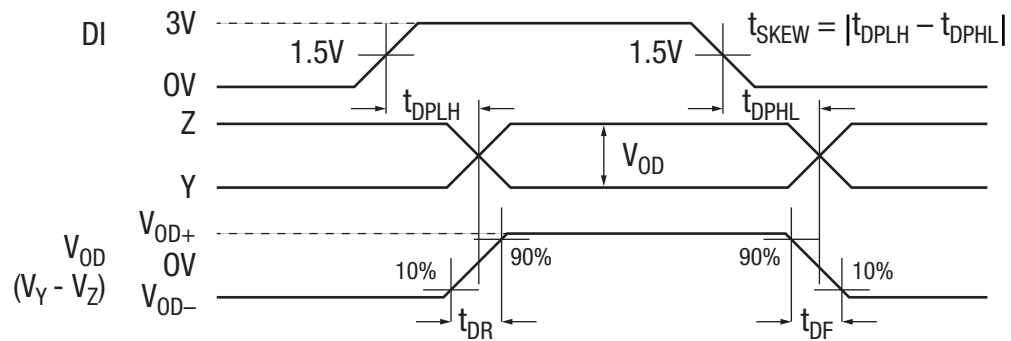

Figure 7. Driver Propagation Delay Test Circuit and Timing Diagram

Applications Information

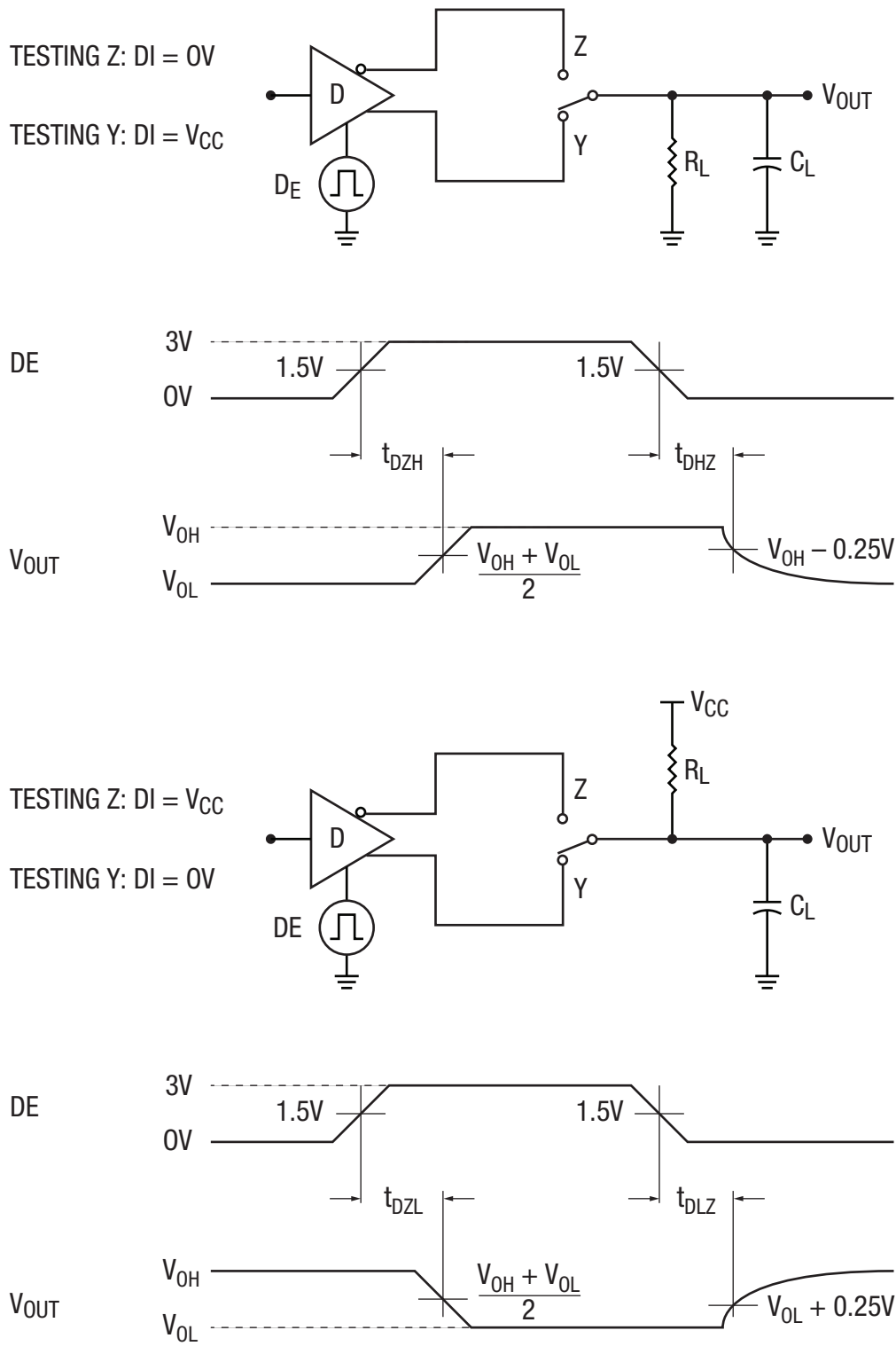

Figure 8. Driver Enable and Disable Timing Test Circuits and Timing Diagrams

Applications Information

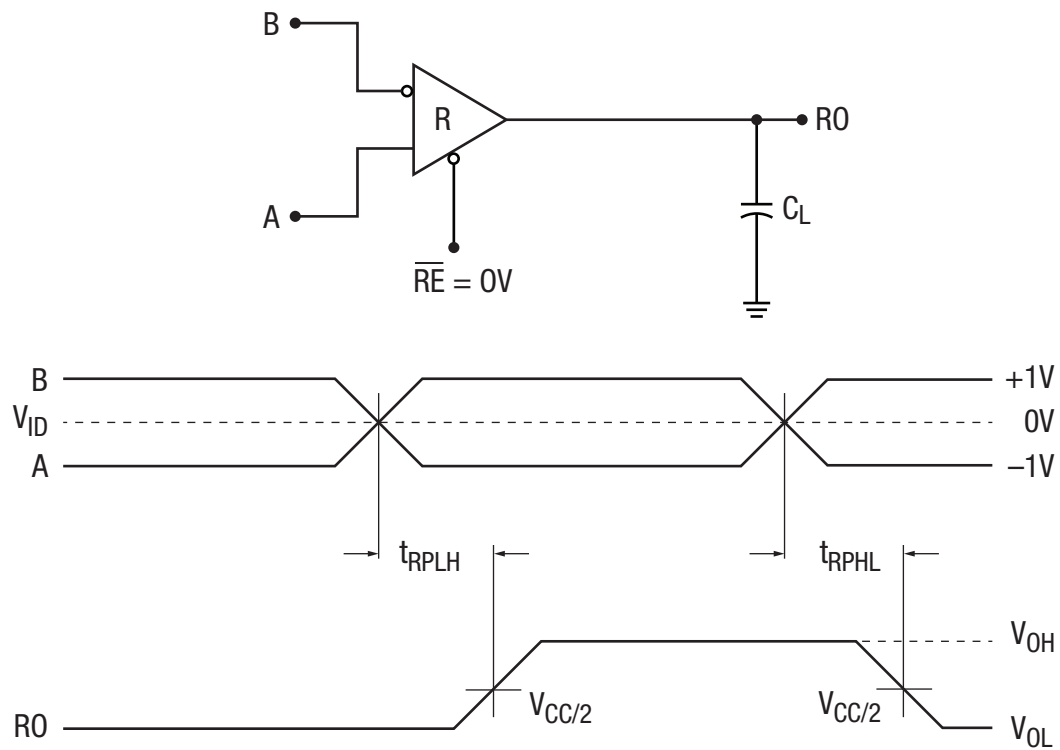

Figure 9. Receiver Propagation Delay Test Circuit and Timing Diagram

Applications Information

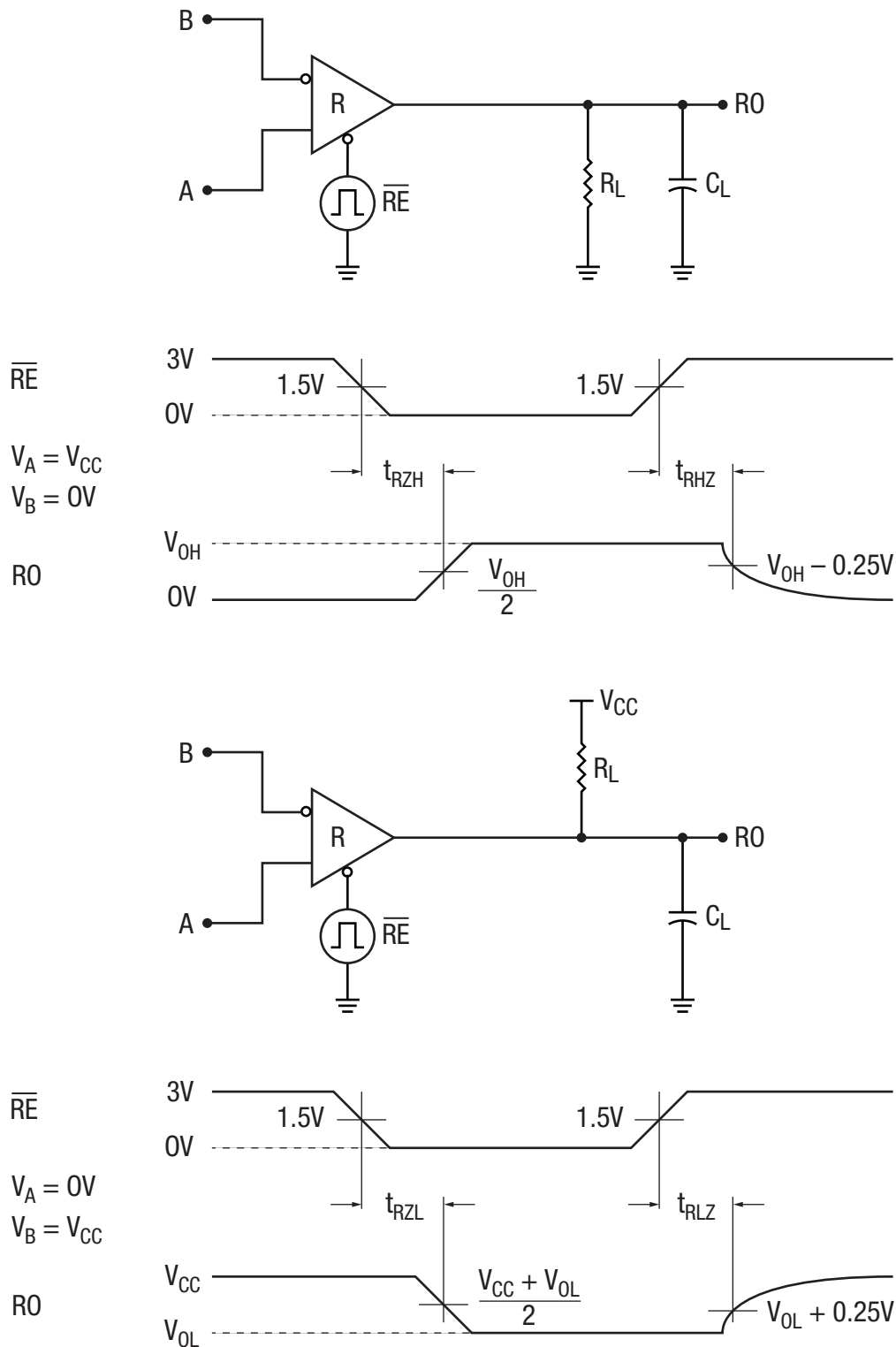

Figure 10. Receiver Enable and Disable Test Circuits and Timing Diagrams

Applications Information

The XR33053 TIA-485/TIA-422 device is part of Exar's high performance serial interface product line. The analog bus pins can survive direct shorts up to $\pm 60V$ and are protected against ESD events up to $\pm 15kV$.

Enhanced Failsafe

Ordinary TIA-485 differential receivers will be in an indeterminate state whenever the data bus is not being actively driven. The enhanced failsafe feature of the XR33053 guarantees a logic-high receiver output when the receiver inputs are open, shorted or when they are connected to a terminated transmission line with all drivers disabled. In a terminated bus with all transmitters disabled, the receivers' differential input voltage is pulled to 0V by the termination. The XR33053 interprets 0V differential as a logic high with a minimum 50mV noise margin while maintaining compliance with the TIA-485 standard of $\pm 200mV$. Although the XR33053 does not need failsafe biasing resistors, it can operate without issue if biasing is used.

Receiver Input Filtering

XR33053 receiver incorporates internal filtering in addition to input hysteresis. This filtering enhances noise immunity by ignoring signals that do not meet a minimum pulse width of 30ns. Receiver propagation delay increases slightly due to this filtering.

Hot Swap Capability

When V_{CC} is first applied, the XR33053 holds the driver enable and receiver enable inactive for approximately 10 μs . During power ramp-up, other system ICs may drive unpredictable values or tristated lines may be influenced by stray capacitance. The hot swap feature prevents the XR33053 from driving any output signal until power has stabilized. After the initial 10 μs , the driver and receiver enable pins are weakly pulled to their disabled states (low for DE, high for \overline{RE}) until the first transition. After the first transition, the DE and \overline{RE} pins operate as high impedance inputs.

If circuit boards are inserted into an energized backplane (commonly called "live insertion" or "hot swap") power may suddenly be applied to all circuits. Without the hot swap capability, this situation could improperly enable the transceiver's driver or receiver, driving invalid data onto shared buses and possibly causing driver contention or device damage.

Driver Output Protection

Two mechanisms prevent excessive output current and power dissipation caused by faults or by bus contention. First, a driver current limit on the output stage provides immediate protection against short circuits over the whole common-mode voltage range. Second, a thermal shutdown circuit forces the driver outputs into a high-impedance state if junction temperature becomes excessive.

Line Length

The TIA-485/TIA-422 standard covers line lengths up to 4000ft. Maximum achievable line length is a function of signal attenuation and noise. Termination prevents signal reflections by eliminating the impedance mismatches on a transmission line. Line termination is generally used if rise and fall times are shorter than the round-trip signal propagation time. Higher output drivers may allow longer cables to be used.

$\pm 15kV$ ESD Protection

ESD protection structures are incorporated on all pins to protect against electrostatic discharges encountered during handling and assembly. The driver outputs and receiver inputs of the XR33053 has extra protection against static electricity. Exar uses state-of-the-art structures to protect these pins against ESD of $\pm 15kV$ without damage. The ESD structures withstand high ESD in all states: normal operation, shutdown and powered down. After an ESD event, the XR33053 keeps operating without latch-up or damage.

ESD protection can be tested in various ways. The transmitter outputs and receiver inputs of the XR33053 is characterized for protection to the following limits:

- $\pm 15kV$ using the Human Body Model, TIA-485 bus pins
- $\pm 4kV$ using the Human Body Model, all other pins

ESD Test Conditions

ESD performance depends on a variety of conditions. Contact Exar for a reliability report that documents test setup, methodology and results.

Maximum Number of Transceivers on the Bus

The standard TIA-485 receiver input impedance is 12k Ω (1 unit load). A standard driver can drive up to 32 unit loads. The XR33053 transceiver has a 1/10th unit load receiver input impedance of 120k Ω , allowing up to 320 transceivers to be connected in parallel on a communication line. Any combination of the XR33053's and other TIA-485 transceivers up to a total of 32 unit loads may be connected to the line.

Low Power Shutdown Mode

Low power shutdown mode is initiated by bringing both \overline{RE} high and DE low simultaneously. While in shutdown devices draw less than $1\mu A$ of supply current. DE and \overline{RE} may be tied together and driven by a single control signal. Devices are guaranteed not to enter shutdown if \overline{RE} is high and DE is low for less than 50ns. If the inputs are in this state for at least 600ns, the parts will enter shutdown.

Enable times t_{ZH} and t_{ZL} apply when the part is not in low power shutdown state. Enable times $t_{ZH(SHDN)}$ and $t_{ZL(SHDN)}$ apply when the parts are shutdown. The driver and receiver take longer to become enabled from low power shutdown $t_{ZH(SHDN)}$ and $t_{ZL(SHDN)}$ than from driver or receiver disable mode (t_{ZH} and t_{ZL}).

Part Number	Operation	Data Rate	Shutdown	Receiver/Driver Enable	Nodes On Bus	Package
XR33053	Full duplex	1Mbps	Yes	Yes/Yes	320	14-pin NSOIC

Package Description

14-Pin NSOIC Package

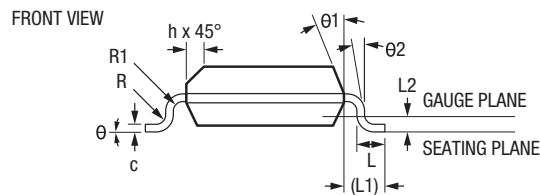
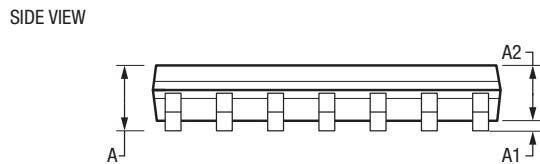
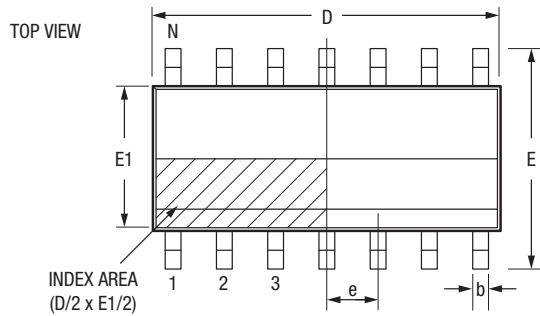

14-Pin NSOIC (JEDEC MS-012)						
Symbols	Dimension in mm (Control unit)			Dimension in inches (Reference unit)		
	Min	Nom	Max	Min	Nom	Max
A	1.35	-	1.75	0.053	-	0.069
A1	0.10	-	0.25	0.004	-	0.010
A2	1.25	-	1.65	0.049	-	0.065
b	0.31	-	0.51	0.012	-	0.020
c	0.17	-	0.25	0.007	-	0.010
E	6.00 BSC			0.236 BSC		
E1	3.90 BSC			0.154 BSC		
e	1.27 BSC			0.050 BSC		
h	0.25	-	0.50	0.010	-	0.020
L	0.40	-	1.27	0.016	-	0.050
L1	1.04 Ref			0.041 Ref		
L2	0.25 BSC			0.010 BSC		
R	0.07	-	-	0.003	-	-
R1	0.07	-	-	0.003	-	-
θ	0°	-	8°	0°	-	8°
θ1	5°	-	15°	5°	-	15°
θ2	0°	-	-	0°	-	-
D	8.65 BSC			0.341 BSC		
N	14			14		

Order Information

Part Number	Operation	Data Rate	Package	Environmental Rating	Operating Temperature Range
XR33053ID-F	Full duplex	1Mbps	14-pin SOIC	Green/RoHS	-40°C to 85°C
XR33053IDTR-F					



www.exar.com

48760 Kato Road
Fremont, CA 94538
USA

Tel.: +1 (510) 668-7000
Fax: +1 (510) 668-7001
Email: support@exar.com

Exar Corporation reserves the right to make changes to the products contained in this publication in order to improve design, performance or reliability. Exar Corporation conveys no license under any patent or other right and makes no representation that the circuits are free of patent infringement. While the information in this publication has been carefully checked, no responsibility, however, is assumed for inaccuracies.

Exar Corporation does not recommend the use of any of its products in life support applications where the failure or malfunction of the product can reasonably be expected to cause failure of the life support system or to significantly affect its safety or effectiveness. Products are not authorized for use in such applications unless Exar Corporation receives, in writing, assurances to its satisfaction that: (a) the risk of injury or damage has been minimized; (b) the user assumes all such risks; (c) potential liability of Exar Corporation is adequately protected under the circumstances.

Reproduction, in part or whole, without the prior written consent of Exar Corporation is prohibited. Exar, XR and the XR logo are registered trademarks of Exar Corporation. All other trademarks are the property of their respective owners.