

# OAB360 Series

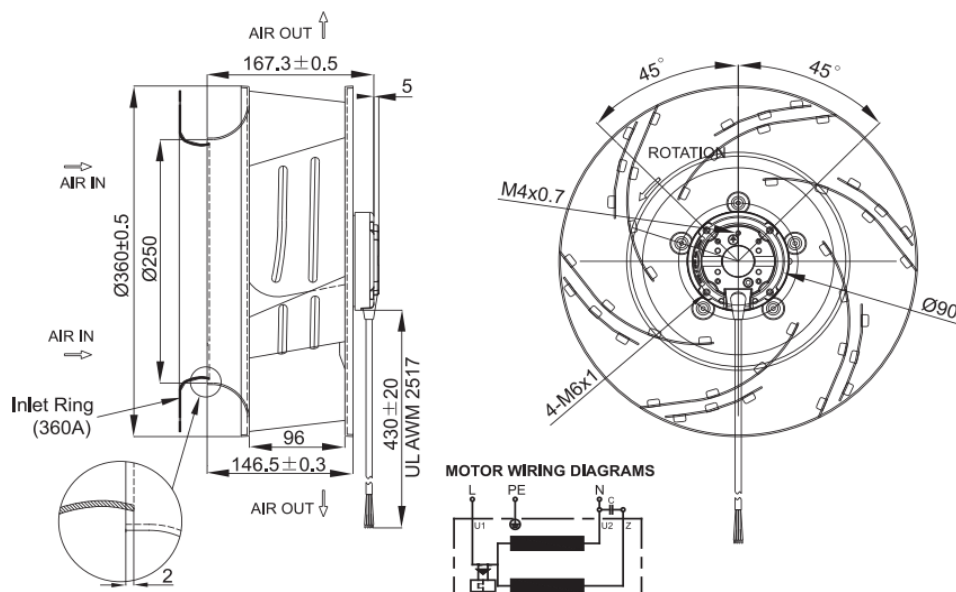

## Motorized Impeller 360 x 167mm (14.2" x 6.57")





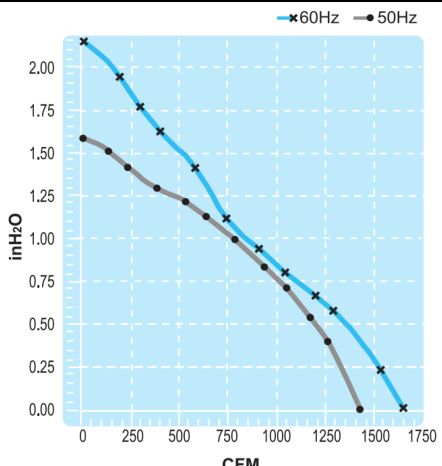

Accessories  
Duct ring DR360A

Part Number	OAB360-11-1	OAB360-22-1	Frame	Diecast Aluminum
Nominal Voltage	115VAC	230VAC	Impeller	Metal
Voltage Range	100 ~ 125VAC	200 ~ 240VAC	Connection	4x Lead wires
Nominal Current	2.30A	1.20A	Motor	AC, Capacitor Run, thermally protected. CAPACITOR INCLUDED IP55 rated
Locked Current	4.00A	2.00A	Bearing System	Dual ball bearing
Rated Power	270W	265W	Insulation Resistance	>100M ohm between leadwire and frame (500VDC) Class B
Rated Speed (RPM)	1600	1600	Dielectric Strength	1500VAC for 1 minute
Airflow (CFM)	1645	1645	Temperature Range	-40C ~ +80C
Noise Level (dB)	70	70	Life (L10)	40,000 hrs (L10, 40C)
Max. Static Pressure	2.2" H <sub>2</sub> O	2.2" H <sub>2</sub> O		
Bearing System	Sealed Dual Ball m2	Sealed Dual Ball		