

Dec.1.2018 Copyright 2018 HIROSE ELECTRIC CO., LTD. All Rights Reserved.
 In case that the application demands a high level of reliability, such as automotive,
 please contact a company representative for further information.

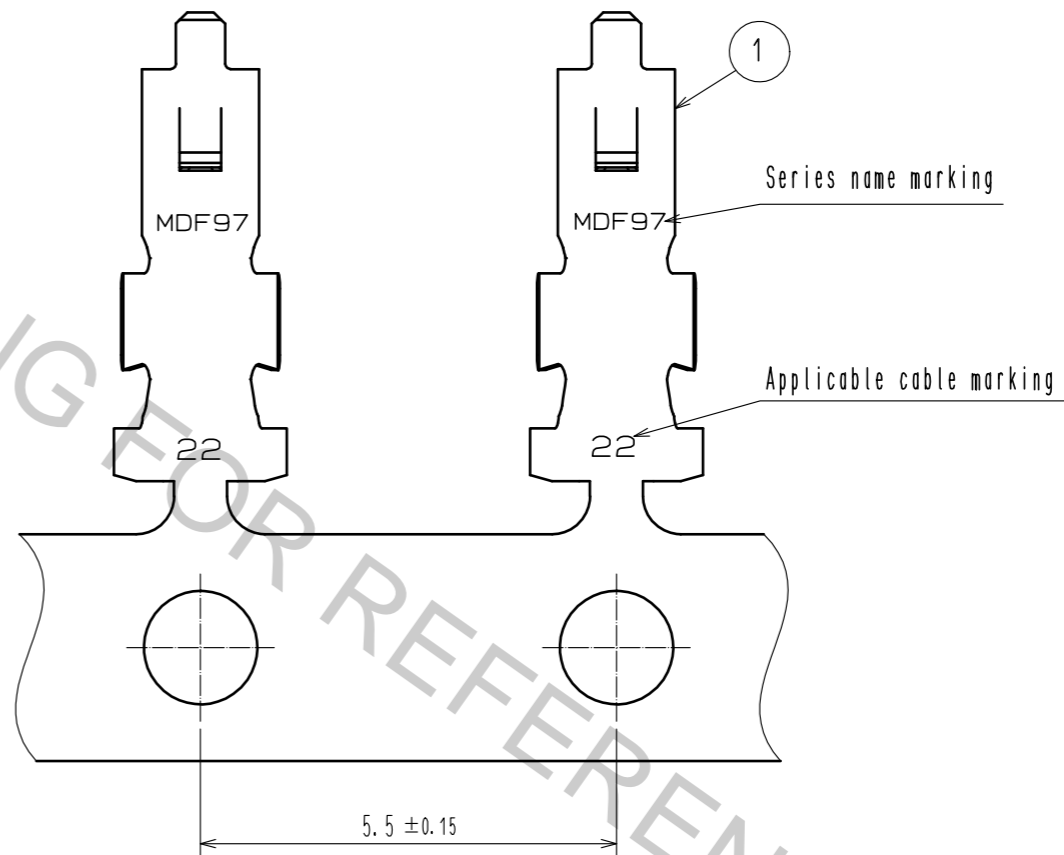
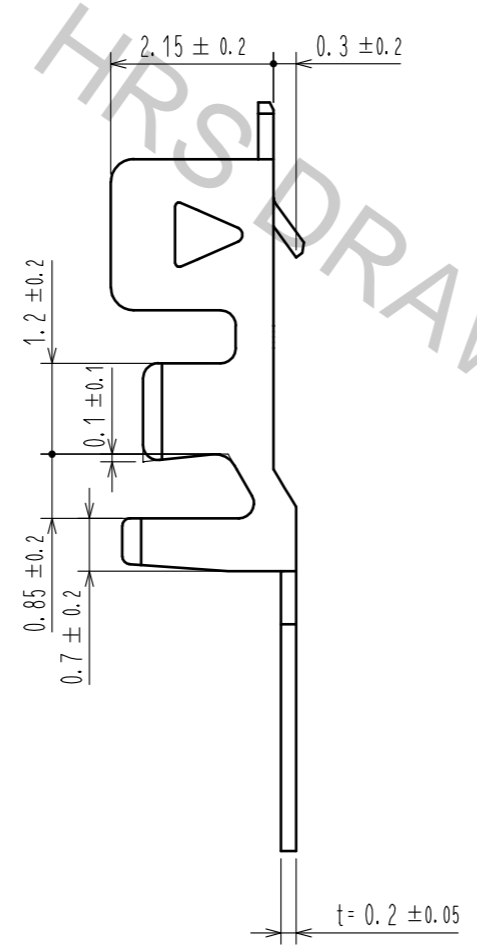
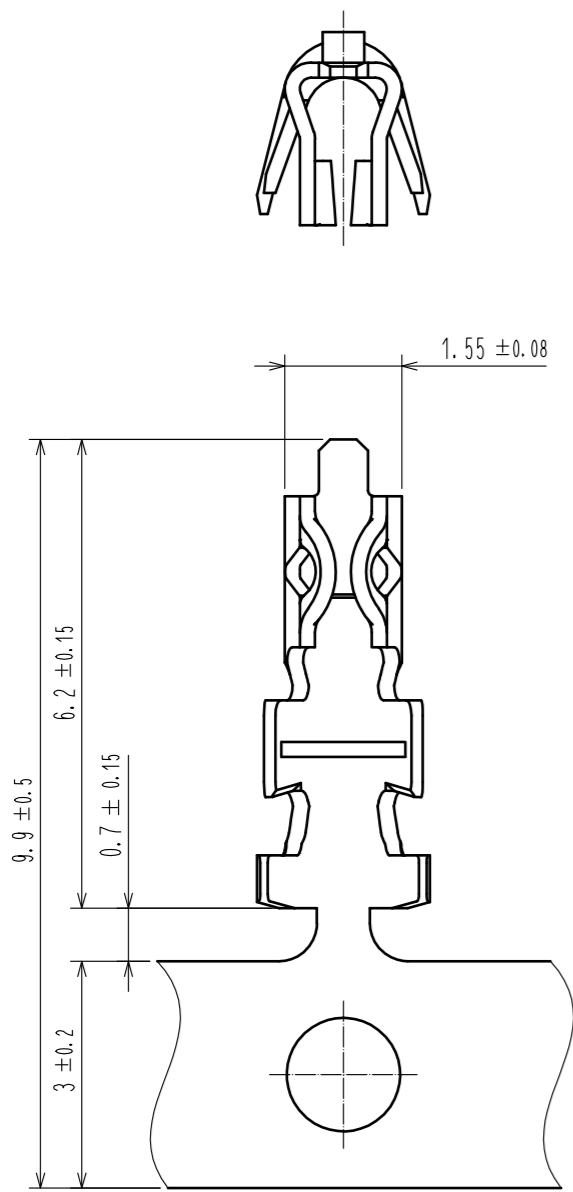

NOTE 1. 1RL:10000 contacts.
 2. Part No. of ORIENTAL MOTOR CO., LTD. : TPMDF97-22SCF

NO.		MATERIAL		FINISH . REMARKS		NO.		MATERIAL		FINISH . REMARKS	
		1		Copper alloy				Surface: Tin plating 1μm min.			
UNITS	mm	SCALE	10:1	COUNT	DESCRIPTION OF REVISIONS	DESIGNED	CHECKED	DATE			
APPROVED : HS. OKAWA		16.11.21		DRAWING NO.		EDC-354810-00-00					
CHECKED : TS. FUKUSHIMA		16.11.21		PART NO.		MDF97-22SCF					
DESIGNED : TS. MIYAKI		16.11.21		CODE NO.		CL547-1102-0-00					
DRAWN : TS. MIYAKI		16.11.21									

Connector should be handled with care. Please use according to below description.

Usage precaution

◆Connector insertion:
After insertion, please confirm that the connector is mated in the correct position.

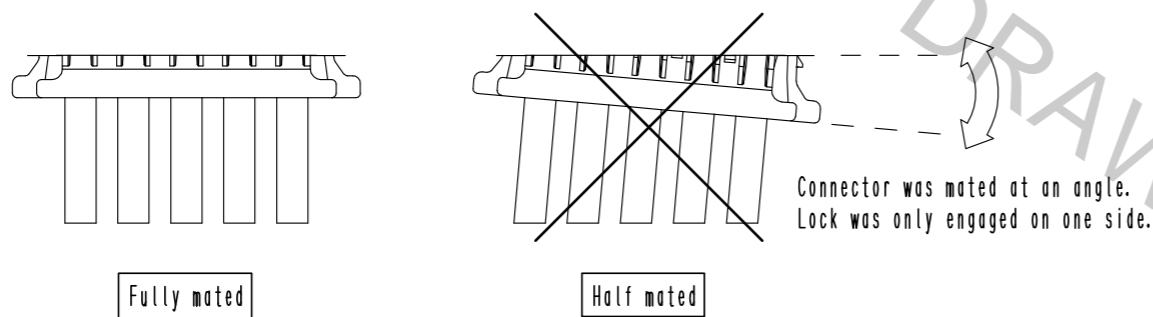
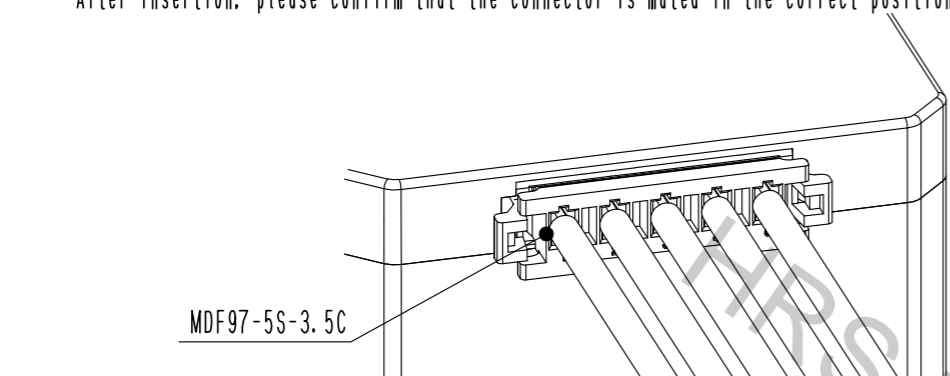

◆Cable wrenching:
When wrenching the cable, please make sure to retain sufficient slack on the cable to lessen the stress on the connector.
Also, if the cable is bend repeatedly or the cable is pulled with, the contact crimp part and connector get stress, resulting in contact failure.

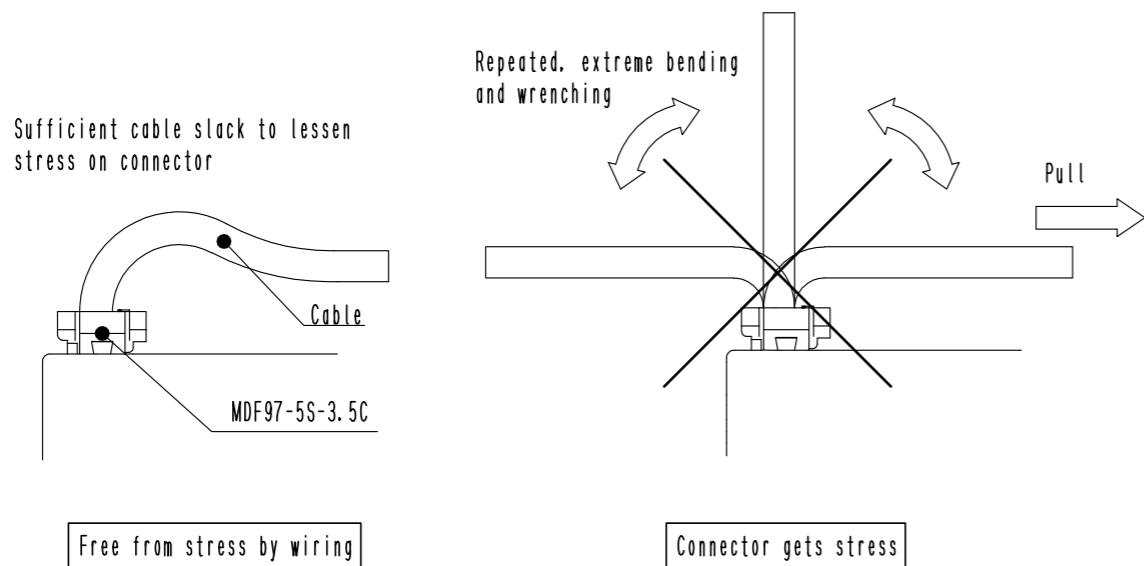

◆Harnessing process (Crimp contact insertion):
Hold the crimp contact by the cable and insert it one by one into the socket holes.
Please avoid insertion at an angle.

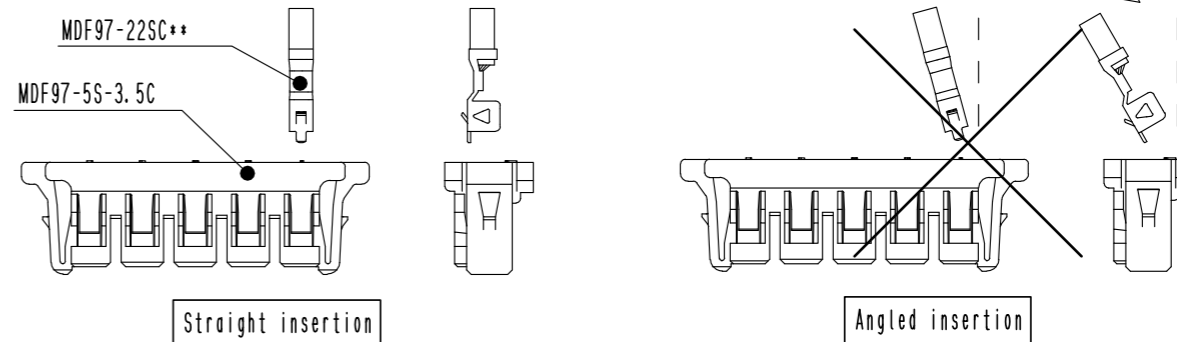

** the omitted two letters define the contact plating and packaging type
(No letters: Tin plated loose piece; F: Tin plated reel; C: Gold plated loose piece; FC: Gold plated reel)

After contact insertion, please confirm the contact lance is properly connected to the housing lance.
(Do so by lighting pulling at the cable)

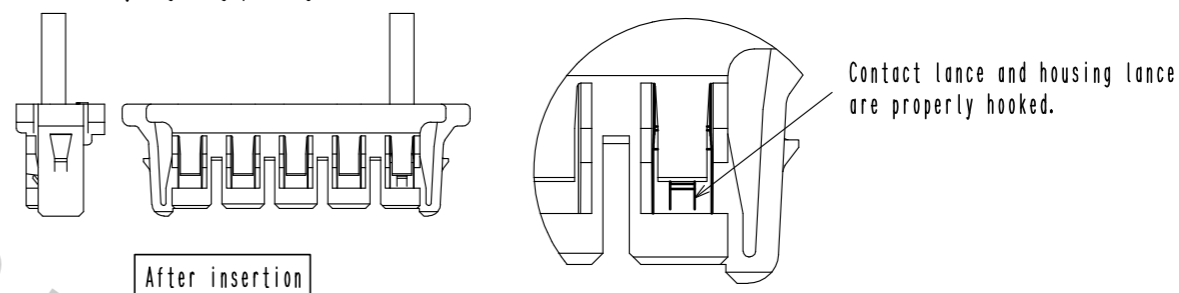

◆Contact removal:
When removing contacts, insert the removal tool into the housing lance groove until it touches the contact lance.
Then, hold the removal tool together with the wire and pull both out of the housing.

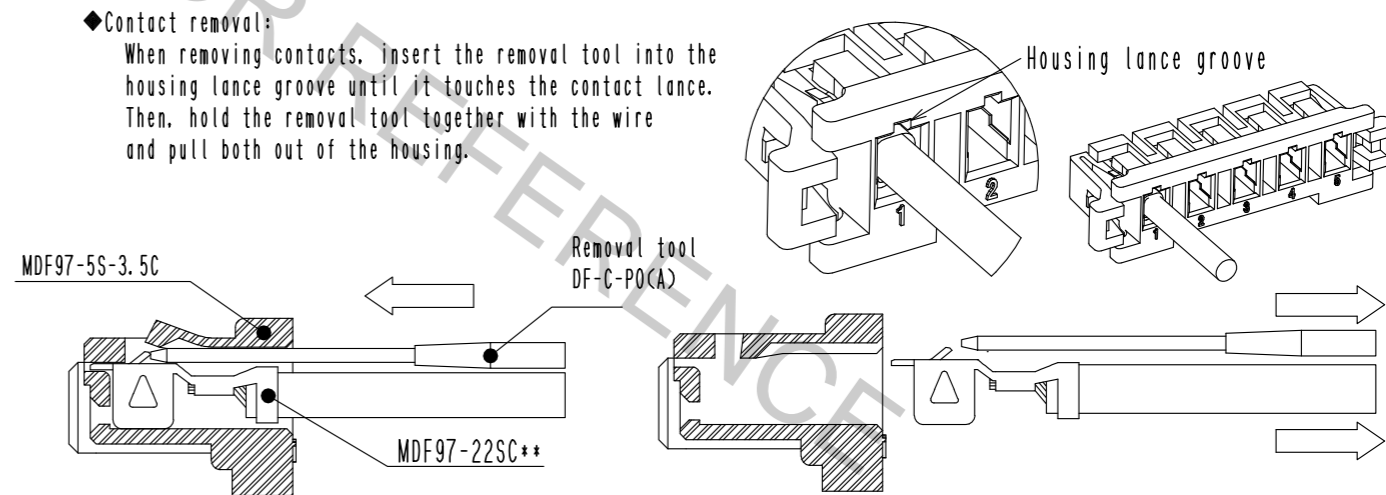

Please take care, that insertion and removal of the tool with excessive force can damage the contact.
Also, since the removal will weaken the socket lance, please do not reuse the same housing.

◆Packing and Storage:
In case of packaging and storage of the harnessed product, please take care not to apply excessive burden to the lock part of the connector.
If a burden is applied to the lock part, and it is exposed to heat and humidity over a long time, the lock part can become deformed, making it unable to mate.

HRS	DRAWING NO.	EDC-354810-00-00
	PART NO.	MDF97-22SCF
	CODE NO.	CL547-1102-0-00
		2/2

Dec.1.2018 Copyright 2018 HIROSE ELECTRIC CO., LTD. All Rights Reserved.
In case that the application demands a high level of reliability, such as automotive, please contact a company representative for further information.