

THIS COPY IS PROVIDED ON A RESTRICTED BASIS AND IS NOT TO BE USED IN ANY WAY DETRIMENTAL TO THE INTERESTS OF PANDUIT CORP.

PANDUIT P/N	WEIGHT
UICFPHSE2**	.67 LB/10 PCS (306.0 g/10 PCS)

NOTES:

- SEE CURRENT CATALOG FOR ADDITIONAL PART NUMBER SUFFIXES TO INDICATE COLOR AND OR PACKAGE QUANTITY.
- SEE CATALOG FOR COMPLETE LIST OF PARTS APPLICABLE FOR USE WITH THIS PART.
- DIMENSIONS IN PARENTHESES ARE IN METRIC.
- PART INCLUDES:
 - 1- FACEPLATE
 - 1- CLEAR SCREW COVER
 - 1- COLOR COORDINATED SCREW COVER
 - 1- CLEAR LABEL COVER
 - 2- MOUNTING SCREW

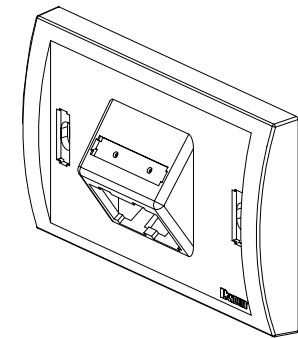
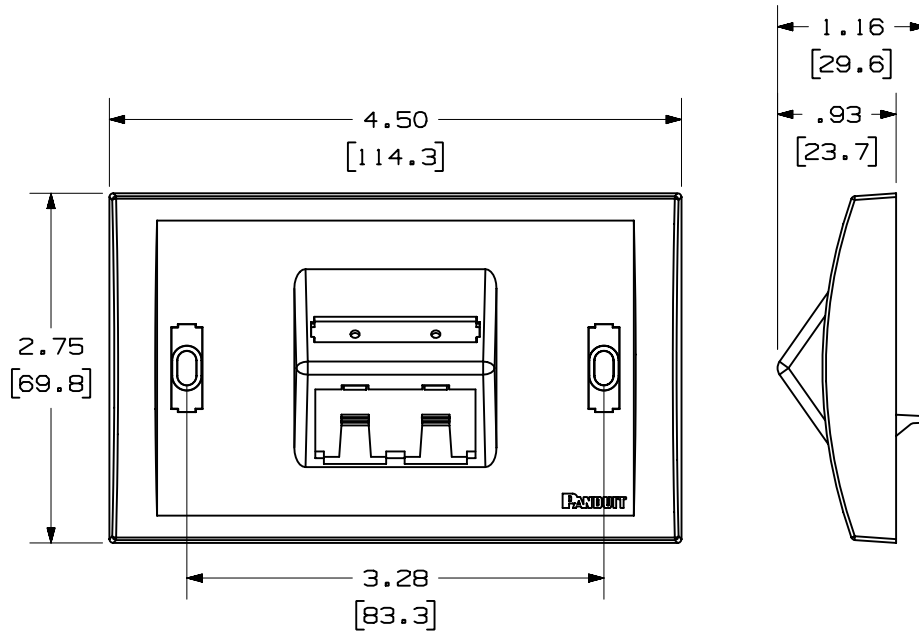

MODEL FILENAME	M01288BE_UICFPHSE2_03.PRT	SIZE	A
DRAWING FILENAME	M01288BE_DC_03A.PRT		

MINI-COM™ ULTIMATE ID™ 2 POSITION
HORIZONTAL SLOPED EXECUTIVE SERIES
FACEPLATE CUSTOMER DRAWING

<p>PANDUIT™ CORP. TINLEY PARK, ILL 60477</p>	I.I. NUMBER	N/A
	PRODUCT SPEC	N/A
	WORK INSTRUCTION	N/A
	SCALE	NONE
<p>THIRD ANGLE PROJECTION</p>	<p>ALL DIMENSIONS ARE GIVEN IN INCHES, UNLESS OTHERWISE SPECIFIED.</p> <p>DIMENSIONAL TOLERANCES ARE: (.X) ± (.XXX) ± .010(.3) (.XX) ± .031(.8) ANGLES ±</p>	PART NO. UICFPHSE2**
<p>DRAWN BY JsP</p> <p>DATE 7-24-02</p> <p>CHK'D</p>	<p>REVIEW DRAWING NUMBERS</p> <p>MATERIAL: ABS</p>	DRAWING NO. 01288-09

R	7-24-02	JsP		RELEASED TO PRODUCTION	01288-09													
REV	DATE	BY	CHK	DESCRIPTION	ECN	R	CUST	SUP	OTH	CHK'D								