



BOURNS®

Features

- Fast tripping resettable circuit protection
- Low internal resistance
- Patents pending
- Weldable nickel terminals
- Agency recognition: 

Applications

- AAA size battery cells

MF-AAA Series - PTC Resettable Fuses

Electrical Characteristics

Model	V max. Volts	I max. Amps	I _h Rated Current	Typical Current Trip Limit						Initial Resistance Values		One Hour Post-Trip Resistance Standard Trip	Maximum Time To Trip	Tripped Power Dissipation
				Amps at 23°C		Amps at 0°C		Amps at 23°C		Amps at 60°C				
			Hold	Trip	Hold	Trip	Hold	Trip	Hold	Trip	Min.	R ₁ Max.	Max.	Seconds at 23°C
MF-AAA170	15	50	1.7	2.0	4.2	1.7	3.7	1.3	2.5	0.050	0.072	0.120	5 @ 8.5A	1.3
MF-AAA210	15	50	2.1	2.3	5.4	2.1	4.5	1.5	3.4	0.036	0.048	0.086	5 @ 10.5A	1.3

Environmental Characteristics

Operating/Storage Temperature-40°C to +85°C
 Maximum Device Surface Temperature
 in Tripped State125°C
 Passive Aging.....+85°C, 1000 hours±5% typical resistance change
 Humidity Aging.....+85°C, 85% R.H. 7 days±5% typical resistance change
 Thermal Shock+85°C to -40°C, 20 times±10% typical resistance change
 Solvent ResistanceMIL-STD-202, Method 215No change
 VibrationMIL-STD-883C, Method ANo change
 Condition A

Test Procedures And Requirements For Model MF-AAA Series

Test	Test Conditions	Accept/Reject Criteria
Visual/Mech.	Verify dimensions and materials.....	Per MF physical description
Resistance	In still air @ 23°C	R _{min} ≤ R ≤ R _{max}
Time to Trip	V _{max} , 23°C	T ≤ max. time to trip (seconds)
Hold Current	30 min. at I _{hold}	No trip
Trip Cycle Life	V _{max} , I _{max} , 100 cycles	No arcing or burning
Trip Endurance.....	V _{max} , 48 hours	No arcing or burning
UL File Number	E 174545S	
CSA File Number	CA 110338	
TÜV File Number	R2057213	

Thermal Derating Chart - I_{hold} (Amps)

Model	Ambient Operating Temperature								
	-40°C	-20°C	0°C	23°C	40°C	50°C	60°C	70°C	85°C
MF-AAA170	2.45	2.21	2.00	1.70	1.56	1.44	1.30	1.19	1.08
MF-AAA210	2.03	2.20	2.30	2.10	1.90	1.71	1.50	1.37	1.29

*I_{trip} is approximately two times I_{hold}.

NOTE: Model MF-AAA is agency approved for 10V.

MF-AAA Series - PTC Resettable Fuses

BOURNS®

Product Dimensions

Model	A	B	C	D	E	F	G	H	K	L
MF-AAA170	$\frac{16.8 \pm 0.3}{(.661 \pm .012)}$	$\frac{9.8 \pm 0.1}{(.386 \pm .004)}$	$\frac{5.0 \pm 0.2}{(.197 \pm .008)}$	$\frac{5.0 \pm 0.2}{(.197 \pm .008)}$	$\frac{1.0 \text{ MAX.}}{(.039 \text{ MAX.})}$	$\frac{5.00 \pm 0.3}{(.197 \pm .012)}$	$\frac{.90 \text{ MAX.}}{(.035 \text{ MAX.})}$	$\frac{.15 \pm .05}{(.006 \pm .002)}$	$\frac{4.5 \pm 0.2}{(.177 \pm .008)}$	$\frac{6.0 \pm 0.5}{(.236 \pm .020)}$
MF-AAA210	$\frac{16.8 \pm 0.3}{(.661 \pm .012)}$	$\frac{9.8 \pm 0.2}{(.386 \pm .012)}$	$\frac{5.0 \pm 0.2}{(.197 \pm .008)}$	$\frac{5.0 \pm 0.2}{(.197 \pm .008)}$	$\frac{1.0 \text{ MAX.}}{(.039 \text{ MAX.})}$	$\frac{5.00 \pm 0.3}{(.197 \pm .012)}$	$\frac{.90 \text{ MAX.}}{(.035 \text{ MAX.})}$	$\frac{.15 \pm .05}{(.006 \pm .002)}$	$\frac{4.5 \pm 0.2}{(.177 \pm .008)}$	$\frac{5.0 \pm 0.5}{(.197 \pm .020)}$

DIMENSIONS = $\frac{\text{MM}}{(\text{IN})}$

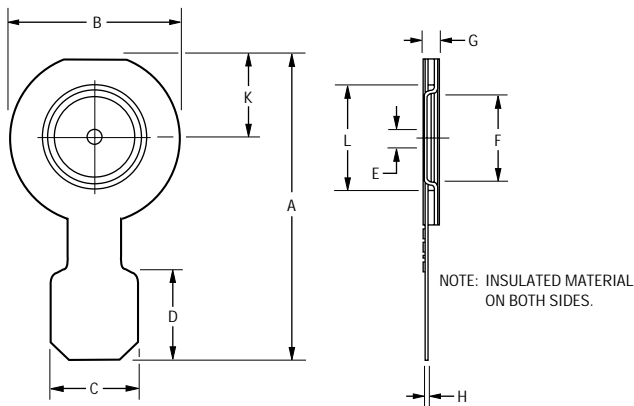

Typical Part Marking

Represents total content. Layout may vary.

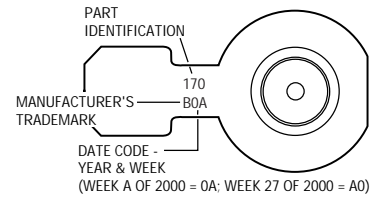

How to Order

MF - AAA 170 - 2

Multifuse® Product _____
 Designator _____
 Series _____
 AAA = Battery Cap Component
 Hold Current, I_{hold} _____
 170 or 210 (1.7 Amps, 2.1 Amps)
 Packaging _____
 Packaged per EIA 481-1
 -2 = Tape and Reel

Typical Time to Trip at 23°C

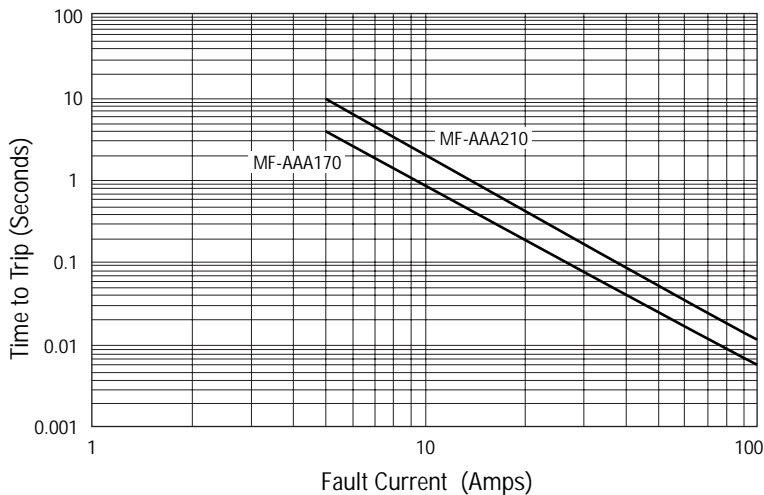

Taped Component Dimensions

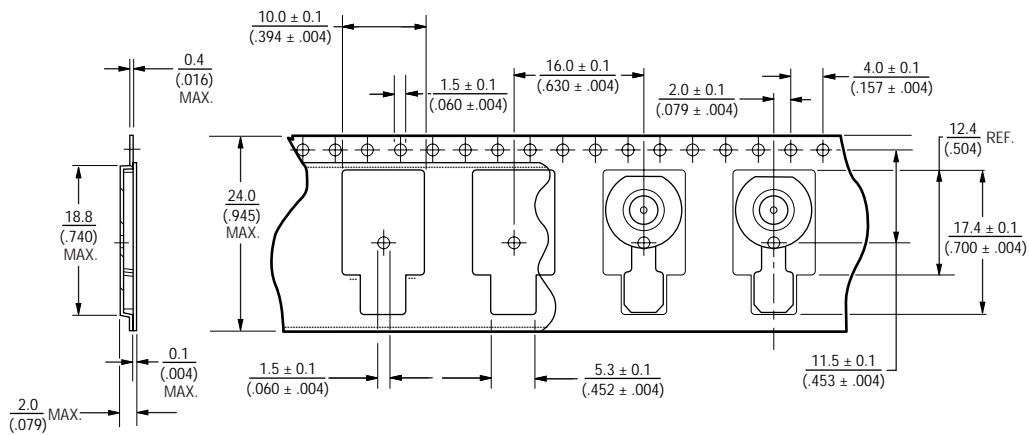

Reel Dimensions

