

DESCRIPTION

Demo circuit 1323 is a current-mode PWM step-down DC/DC regulator with an internal 1.2A power switch featuring the LT3686. The demo circuit is designed for 3.3V output from a 5V to 37V input. The wide input range of the LT3686 allows a variety of input sources. The typical sources are automotive batteries and industrial supplies. Its high maximum frequency allows the use of tiny inductors and capacitors. Operating frequency above the AM band avoids interfering with radio reception, making the LT3686 particularly suitable for automotive applications.

Cycle by cycle current limit and DA current sense provide the protection against shorted outputs. Soft-start and frequency foldback eliminate input current surge during startup. An optional internal regulated active load at the output via the BD pin keeps the LT3686 at full switching

frequency at light loads, resulting in low, predictable output ripple above the audio and AM bands. Internal compensation and an internal boost diode reduce external component count.

The LT3686 datasheet gives a complete description of the part, operation and application information. The datasheet must be read in conjunction with this quick start guide for Demo Circuit 1323.

LT3686 is available in 3mmx3mm DFN package.

Design files for this circuit board are available. Call the LTC factory.

LT, LTC, LTM, LT and uModule are registered trademarks of Linear Technology Corporation. All other trademarks are the property of their respective owners.

Performance Summary ($T_A = 25^{\circ}\text{C}$)

| PARAMETER | CONDITION | VALUE |
|--------------------------|---|---------------|
| Minimum Input Voltage | | 5V |
| Maximum Input Voltage | | 37V |
| Output Voltage V_{OUT} | | 3.3V \pm 3% |
| Switching Frequency | | 1MHz |
| Maximum Output Current | $V_{IN}=5\sim 37\text{V}$ | 1.2A |
| Efficiency | $V_{IN}=12\text{V}$, $I_{OUT}=1.0\text{A}$ | 80.7% |
| Voltage Ripple | $V_{IN}=12\text{V}$, $I_{OUT}=1.0\text{A}$ | 20mV |

QUICK START PROCEDURE

Demonstration circuit 1323 is easy to set up to evaluate the performance of the LT3686. Refer to Figure 1 for proper measurement equipment setup and follow the procedure below:

NOTE . When measuring the input or output voltage ripple, care must be taken to avoid a long ground lead on the oscilloscope probe. Measure the input or output voltage ripple by touching the probe tip directly across the Vin or Vout and GND terminals. See Figure 2 for proper scope probe technique.

1. Place JP1 on the ON position.
2. With power off, connect the input power supply to Vin and GND.

3. Turn on the power at the input.

NOTE . Make sure that the input voltage does not exceed 55V.

4. Check for the proper output voltage.

NOTE . If there is no output, temporarily disconnect the load to make sure that the load is not set too high.

5. Once the proper output voltage is established, adjust the load within the operating range and observe the output voltage regulation, ripple voltage, efficiency and other parameters.

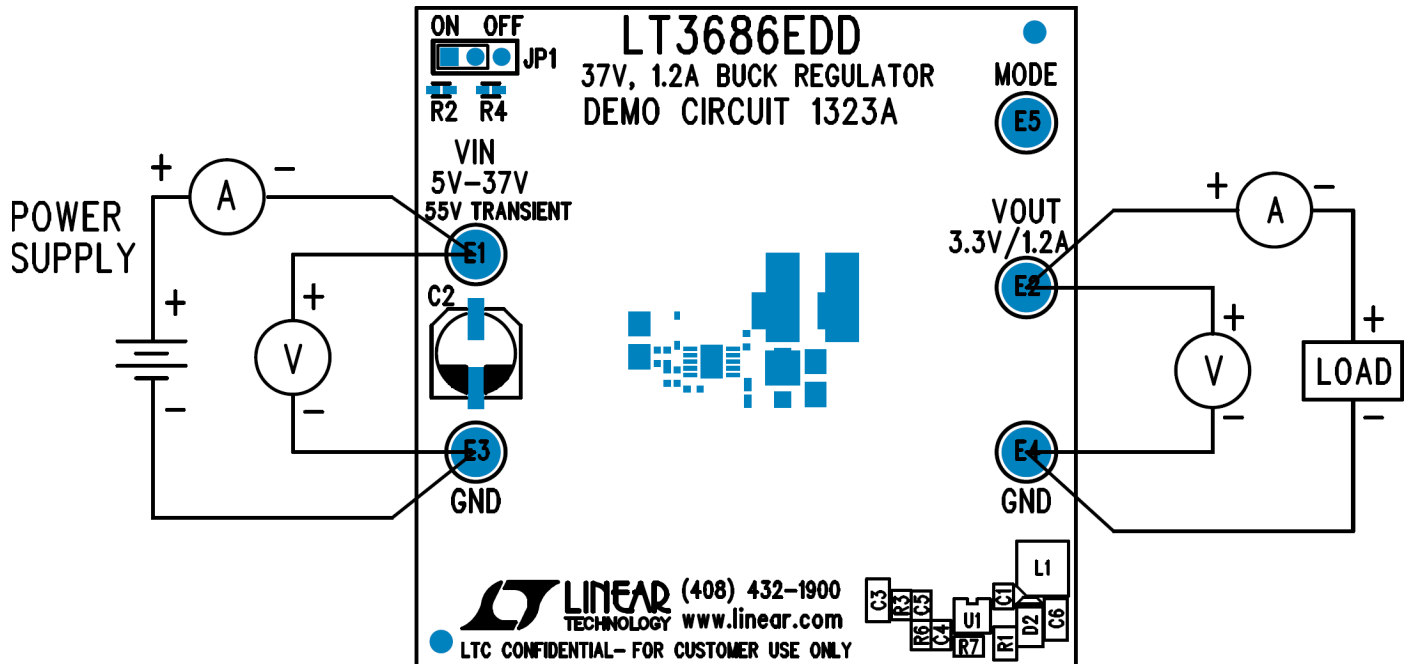

Figure 1. Proper Measurement Equipment Setup

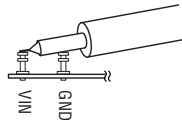
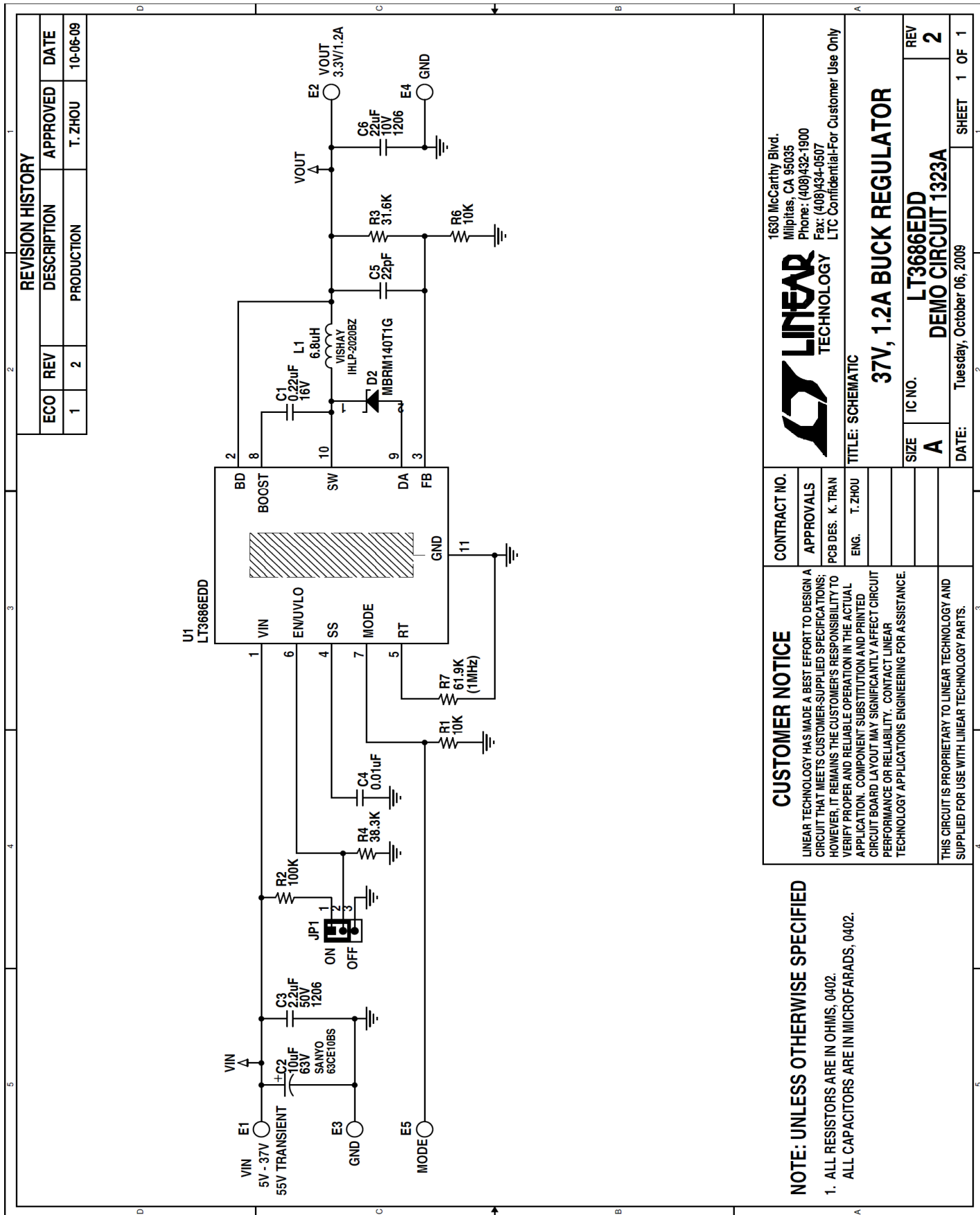

Figure 2. Measuring Input or Output Ripple



| REVISION HISTORY | | | | |
|------------------|-----|-------------|----------|----------|
| ECO | REV | DESCRIPTION | APPROVED | DATE |
| 1 | 2 | PRODUCTION | T. ZHOU | 10-06-09 |

| | | | |
|---------------------------------|-----------|---|-----|
| CONTRACT NO. | | 1630 McCarthy Blvd. Milpitas, CA 95035 Phone: (408)432-1900 Fax: (408)434-0507 LTC Confidential-For Customer Use Only | |
| APPROVALS | | | |
| PCB DES. K. TRAN | | TITLE: SCHEMATIC | |
| ENG. T. ZHOU | | 37V, 1.2A BUCK REGULATOR | |
| SIZE | IC NO. | REV | REV |
| A | LT3686EDD | 2 | 2 |
| DATE: Tuesday, October 06, 2009 | | SHEET 1 OF 1 | |

CUSTOMER NOTICE

LINEAR TECHNOLOGY HAS MADE A BEST EFFORT TO DESIGN A CIRCUIT THAT MEETS CUSTOMER-SUPPLIED SPECIFICATIONS; HOWEVER, IT REMAINS THE CUSTOMER'S RESPONSIBILITY TO VERIFY PROPER AND RELIABLE OPERATION IN THE ACTUAL APPLICATION. COMPONENT SUBSTITUTION AND PRINTED CIRCUIT BOARD LAYOUT MAY SIGNIFICANTLY AFFECT CIRCUIT PERFORMANCE OR RELIABILITY. CONTACT LINEAR TECHNOLOGY APPLICATIONS ENGINEERING FOR ASSISTANCE.

THIS CIRCUIT IS PROPRIETARY TO LINEAR TECHNOLOGY AND SUPPLIED FOR USE WITH LINEAR TECHNOLOGY PARTS.

NOTE: UNLESS OTHERWISE SPECIFIED

1. ALL RESISTORS ARE IN OHMS, 0402.
ALL CAPACITORS ARE IN MICROFARADS, 0402.