

THIS DRAWING IS UNPUBLISHED. RELEASED FOR PUBLICATION 20  
 © COPYRIGHT 20 BY - ALL RIGHTS RESERVED.

REVISIONS					
P	LTR	DESCRIPTION	DATE	DWN	APVD
	A	INITIAL RELEASE	14OCT2016	YC	CW

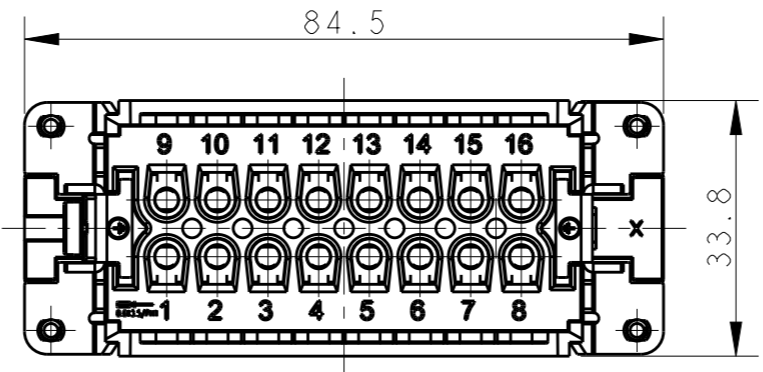

16X M3 SCREW, RECOMMENDED TIGHTENING TORQUE 0.5Nm  
 16X M3螺丝, 推荐锁紧力矩0.5Nm

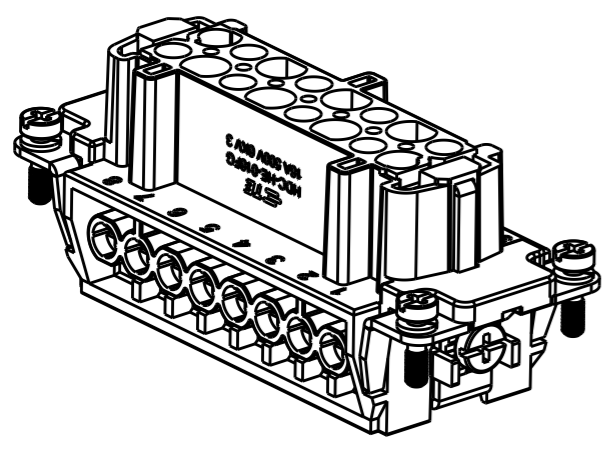
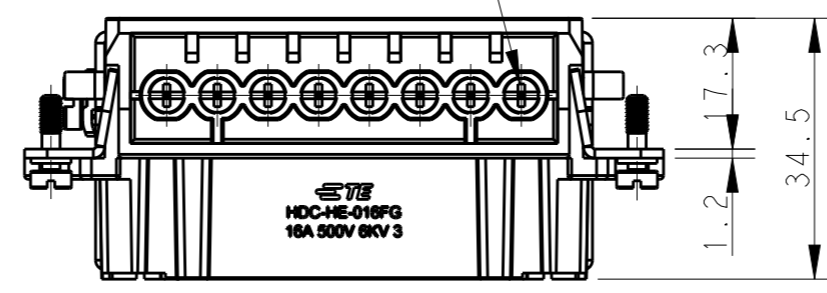
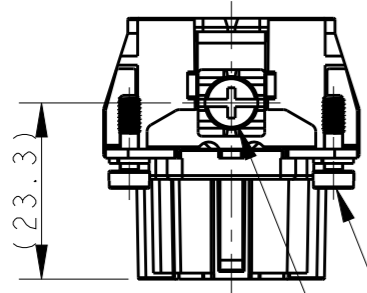

4X M3 SCREW, RECOMMENDED TIGHTENING TORQUE 0.5Nm  
 4X M3螺丝, 推荐锁紧力矩0.5Nm

M4 SCREW, RECOMMENDED TIGHTENING TORQUE 1.2Nm  
 M4螺丝, 推荐锁紧力矩1.2Nm

NOTES:  
 1. TECHNICAL CHARACTERISTICS:  
 INSULATION MATERIAL: PC  
 RATED VOLTAGE: 500V  
 RATED CURRENT: 16A  
 INSULATION RESISTANCE: >=400MΩ  
 RATED IMPULSE VOLTAGE: 6KV  
 POLLUTION DEGREE: 3  
 FLAMMABILITY: UL94V-0  
 MATING CYCLES: 500 CYCLES  
 WIRE RANGE: 0.5mm<sup>2</sup>~2.5mm<sup>2</sup> (AWG20-AWG14)  
 CONTACT TYPE: SCREW CLAMP (M3)

注释:  
 1. 技术参数:  
 绝缘材料: PC  
 额定电压: 500V  
 额定电流: 16A  
 绝缘电阻: >=400MΩ  
 脉冲电压: 6KV  
 污染等级: 3  
 阻燃等级: UL94V-0  
 插拔次数: 500 次  
 接线范围: 0.5mm<sup>2</sup>~2.5mm<sup>2</sup> (AWG20-AWG14)  
 接线类型: 螺丝压接 (M3)

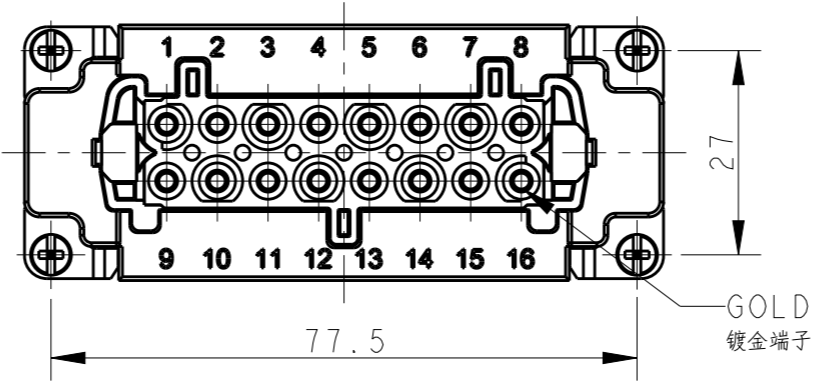
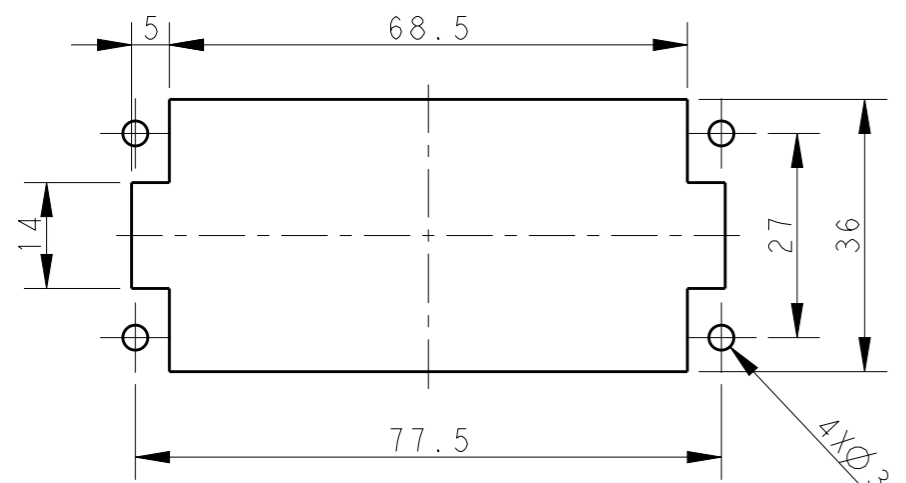

PANEL CUT FOR INSERTS FOR USE WITHOUT HOODS/ HOUSINGS  
 不使用防护外壳时芯件的安装开孔图

T2040162211-000	HE-016-FG	HE-016 FEMALE INSERT, GOLD PLATED HE-016 母插, 镀金
PART NUMBER 料号	PART DESCRIPTION 描述	

THIS DRAWING IS A CONTROLLED DOCUMENT.		DWN 14OCT2016 YORK CHEN	TE Connectivity	
		CHK 14OCT2016 KYLE ZENG		
		APVD 14OCT2016 CHRIS WANG	NAME HE-016-FG	
DIMENSIONS: mm		PRODUCT SPEC 108-137044	RESTRICTED TO	
TOLERANCES UNLESS OTHERWISE SPECIFIED:		APPLICATION SPEC 114-137044	SIZE A3	CAGE CODE 00779
MATERIAL		WEIGHT	DRAWING NO T2040162211000	
		CUSTOMER DRAWING	SCALE 1:1	SHEET 1 OF 1
			REV A	