

Product Overview

The Qorvo® QPB9320 is a highly integrated front-end module targeted for TDD macro or picocell base stations. The LNA switch module integrates RF functional blocks such as a pin-diode based high power switch capable of handling up to 52 W with an LTE signal (8 dB PAR) along with two LNA stages. Further integration is also implemented where the PIN diode driver and DC-DC converter circuits are implemented inside the module to enable only the need for an external 5 V power supply. The control voltage for the switch and gain control. mode is with 3.3 V logic.

The QPB9320 can be utilized across the 1.850-2.025 GHz range to provide 1.1 dB noise figure for operation in the receive mode and 0.5 dB insertion loss in the transmit mode. The LNAs utilize Qorvo’s high performance E-pHEMT process while the switch allows for power levels up to 330 W peak power to be routed to an external load termination.

The QPB9320 is packaged in a RoHS-compliant, compact 8x8 mm surface-mount leadless package. The switch LNA module is targeted for wireless infrastructure applications configured for TDD-based architectures.

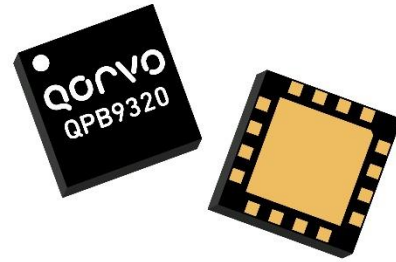

16 Pin 8 mm x 8 mm Leadless SMT Package

Key Features

- 1.850-2.025 GHz frequency range
- Integrates a high-power switch, two LNA stages, PIN diode driver circuits, and DC-DC converter
- Ideal for TDD systems with an isolator
- Only requires a 5 V supply with 3.3 V logic Ctrl.
- Max RF Input power: 52 W Pavg (8 dB PAR)
- 32.5 dB gain
- 1.1 dB noise figure
- -1.0 dBm IIP3 (Rx mode)
- 0.5 dB Insertion Loss (Tx mode)
- Compact package size, 8x8 mm

Functional Block Diagram

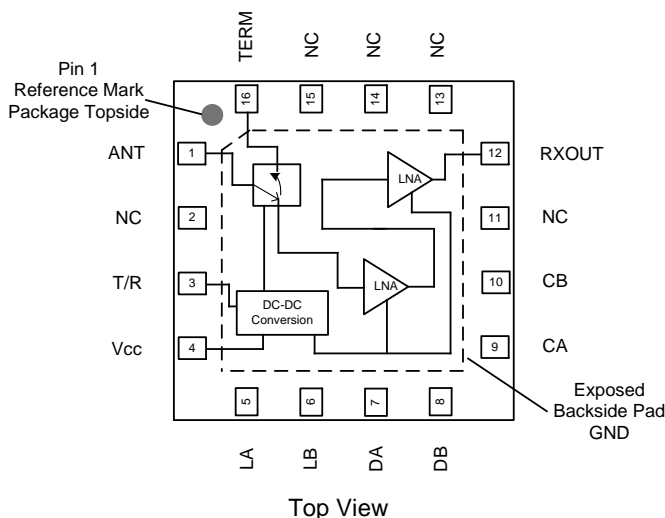

Applications

- Wireless Infrastructure
- Macro or picocell base stations
- TDD-based architectures

Ordering Information

Part No.	Description
QPB9320TR13	2500 pcs on a 13" reel
QPB9320SR	100 pcs on a 7" reel
QPB9320EVb	Evaluation board

Absolute Maximum Ratings

Parameter	Rating
Storage Temperature	-50 to 150 °C
Max Operating Temperature	+115 °C
V _{CC}	+6 V
RF at ANT (Tx Mode) ⁽¹⁾	+47.2 dBm
RF at ANT (Tx Mode) ⁽²⁾	+44.2 dBm
RF at ANT (Rx Mode) ⁽²⁾	+20 dBm

Notes:

1. 10s, 8 dB PAR, 88% duty cycle, +100 °C, 1CH LTE
2. Indefinitely, 8 dB PAR, 88% duty cycle, +100 °C, 1CH LTE

Operation of this device outside the parameter ranges given above may cause permanent damage.

Recommended Operating Conditions

Parameter	Min	Typ	Max	Units
V _{CC}	+4.75	+5	+5.25	V
T/R Logic Low Voltage	0		0.8	V
T/R Logic High Voltage	2.00		3.6	V
T _{CASE}	-40		+105	°C
T _j for >10 ⁶ hours MTTF ⁽³⁾			+190	°C

Notes:

3. For R_x Mode operation

Electrical specifications are measured at specified test conditions. Specifications are not guaranteed over all recommended operating conditions.

Electrical Specifications

Test conditions unless otherwise noted: V_{CC} = +5.0 V, Temp. = +25 °C, 50 Ω system

Parameter	Conditions	Min	Typ	Max	Units
Operational Frequency Range		1850		2025	MHz
Test Frequency			1900		MHz
Gain	Rx mode		32.5		dB
Gain Flatness	Rx mode		0.6		dB
Noise Figure	Rx mode		1.1		dB
Input IP3	Rx mode, Pin/tone = -33dBm, Δf = 1MHz		-1.0		dBm
Input P1dB	Rx mode		-11.6		dBm
Input Return Loss (ANT)	Rx mode		20		dB
Output Return Loss (Rx Out)	Rx mode		34		dB
Reverse Isolation	Rx mode		54		dB
Insertion Loss	Tx mode		0.5		dB
Input P0.1dB	Tx mode		46.6		dBm
Return Loss (ANT, TERM)	Tx mode		20		dB
Operating Current	Rx mode		230		mA
Operating Current	Tx mode		140		mA
Switching Time (ANT to Rx Out)	Reaching full RF output less 0.1dB after T/R command		1.8		uS
Switching Time (ANT to Term)			0.5		uS
Wakeup Time (ANT to Rx Out/Term)	Reaching full RF output less 0.5dB after DC turned on		0.5		s
In Band Spurious Emission ⁽⁴⁾	Rx Mode at Rx out with Pin = -49dBm ⁽⁵⁾		-75		dBc
Out of Band Emissions ⁽⁶⁾	Rx Mode at Rx out from DC to 12275MHz		-85		dBm
Thermal Resistance	Rx mode			26.0	°C/W
Thermal Resistance	Tx mode			20.7	°C/W

Notes:

4. Pin is a CW signal swept from 1.850 to 2.025GHz. Spec refers to any spurious mixing product that occurs from 1.850 to 2.025GHz.
5. Recommend to follow Qorvo EVB layout for lowest spur level. Any deviation can increase spur level.
6. Measure Pout with IBW = 4.5MHz over frequency range with no input power applied.

Application Circuit Schematic and Layout

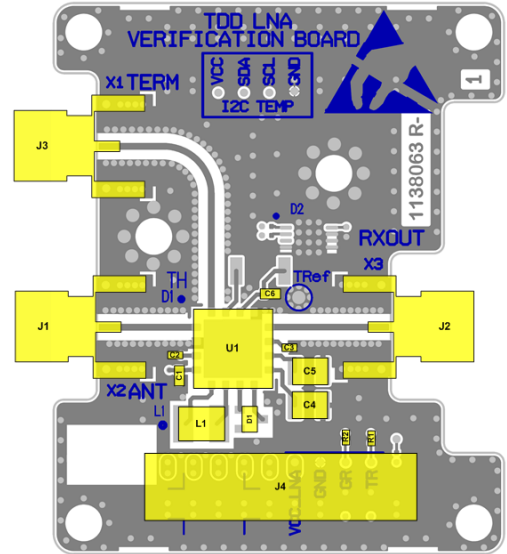
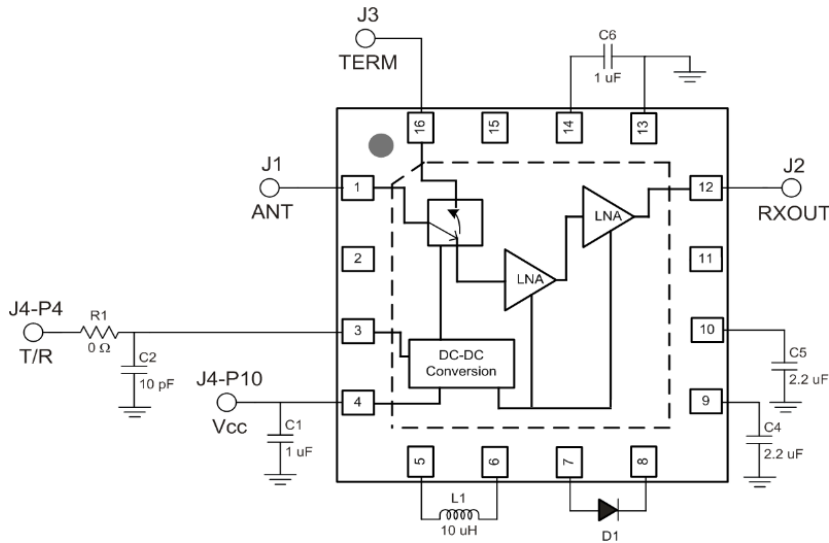

Bill of Material

Ref Des	Value	Description	Manuf.	Part Number
n/a	n/a	Printed Circuit Board		
U1	n/a	High Power Switch LNA Module	Qorvo	QPB9320
R1, R2	0 Ω	Resistor, Chip, 0402, 5%	Various	
C1, C6	1 uF	Capacitor, Chip, 0603, 20%, X7R	Various	
C2, C3	10 pF	Capacitor, Chip, 0402, NPO/COG, 5%	Various	
C4, C5	2.2 uF	Capacitor, Chip, 1210, 100 V, 10%, X7R	Various	
D1	n/a	Diode, 200 V 200 mA SOT23	Various	
L1	10 uH	Inductor, Power, 10 uH, 20%, 0.84 A	TDK	VLCF4020T-100MR85

Logic Table

Parameter	High	Low
T/R	Rx Mode	Tx Mode

Typical Performance of QPB9320EVB – Rx Mode

Parameter	Conditions ⁽¹⁾	Typical Value			Units
Frequency		1850	1900	2025	MHz
Gain		32.7	32.5	32.1	dB
Input IP3	Pin = -33 dBm/tone, Δf=1 MHz	-0.8	-1.0	-0.8	dBm
Input P1dB		-12.0	-11.6	-10.7	dBm
Noise Figure	De-embedded from Evaluation board PCB	1.1	1.1	1.2	dB
Return Loss	ANT port	17	20	35	dB
Return Loss	Rx Out port	28	34	17	dB
Reverse Isolation	Rx Out to ANT port	54	54	57	dB

Notes:

1. Test conditions unless otherwise noted: $V_{CC} = +5.0\text{ V}$, $T/R = 3\text{ V}$, Temp. = $+25\text{ }^{\circ}\text{C}$

Performance Plots of QPB9320EVB – Rx Mode

Test conditions unless otherwise noted: $V_{CC} = +5.0\text{ V}$, $T/R = 3\text{ V}$; Temp. = $+25\text{ }^{\circ}\text{C}$

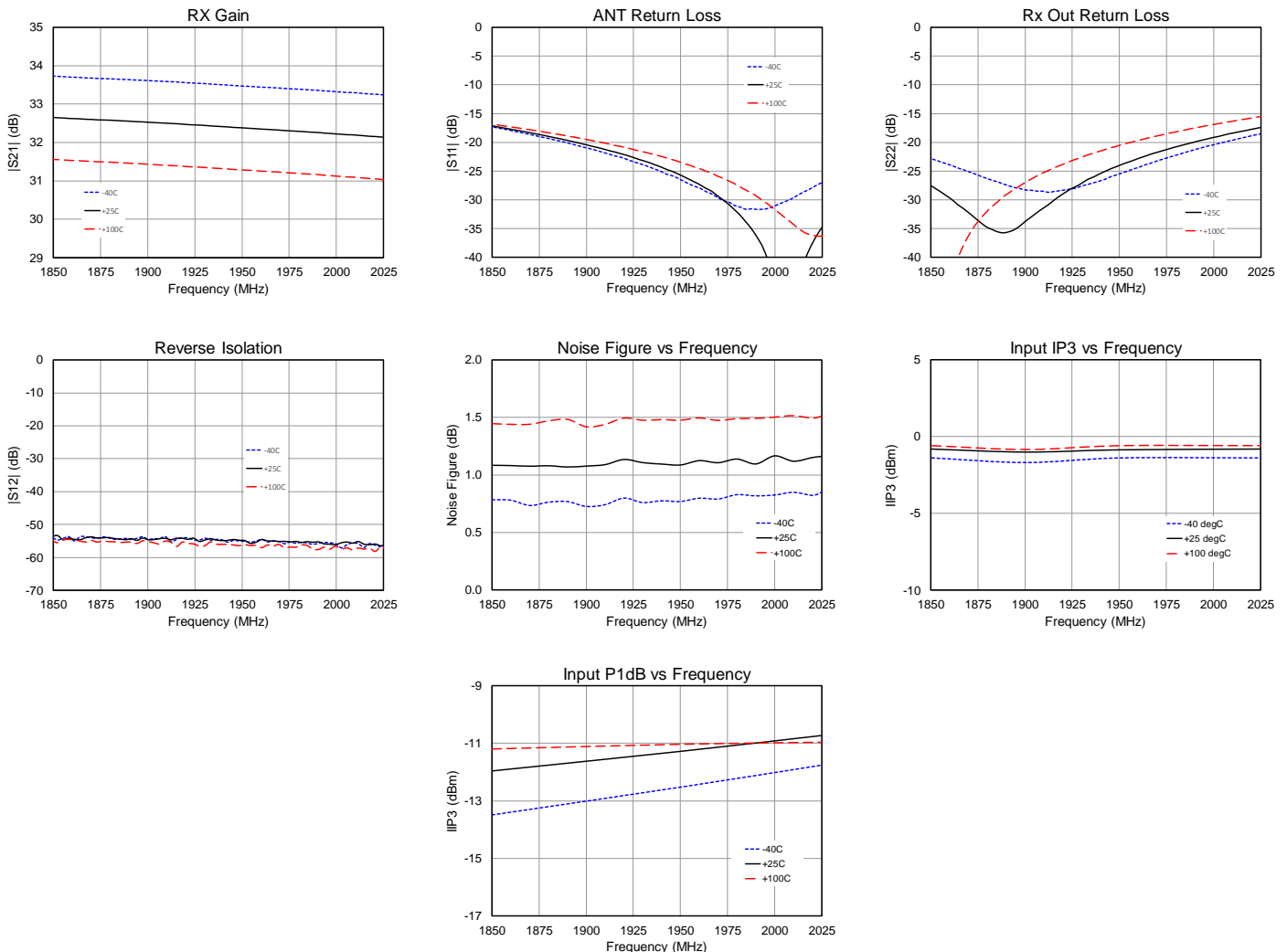

Typical Performance of QPB9320EVB – Tx Mode

Parameter	Conditions ⁽¹⁾	Typical Value			Units
Frequency		1850	1900	2025	MHz
Insertion Loss	De-embedded from Evaluation board PCB	0.6	0.5	0.5	dB
Input Compression	Pin = +46.6 dBm, Temp. = +100 °C	0.07	-	0.09	dB
Return Loss	ANT port	17	20	27	dB
Return Loss	TERM port	17	20	24	dB

Notes:

1. Test conditions unless otherwise noted: $V_{CC} = +5.0\text{ V}$, $T/R = 0\text{ V}$, Temp. = +25 °C

Performance Plots of QPB9320EVB – Tx Mode

Test conditions unless otherwise noted: $V_{CC} = +5.0\text{ V}$, $T/R = 0\text{ V}$; Temp. = +25 °C

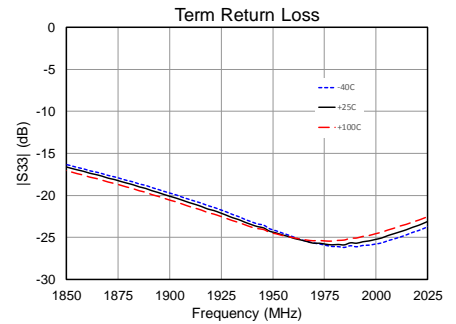
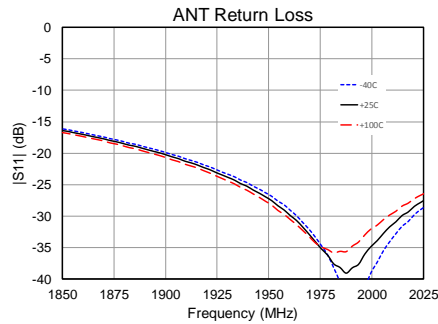
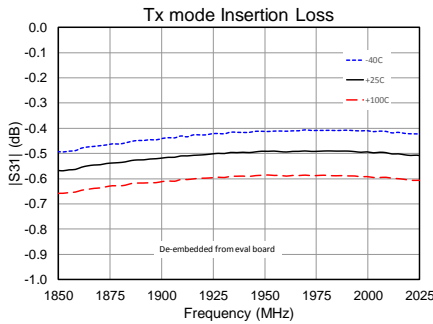

Pin Configuration and Description

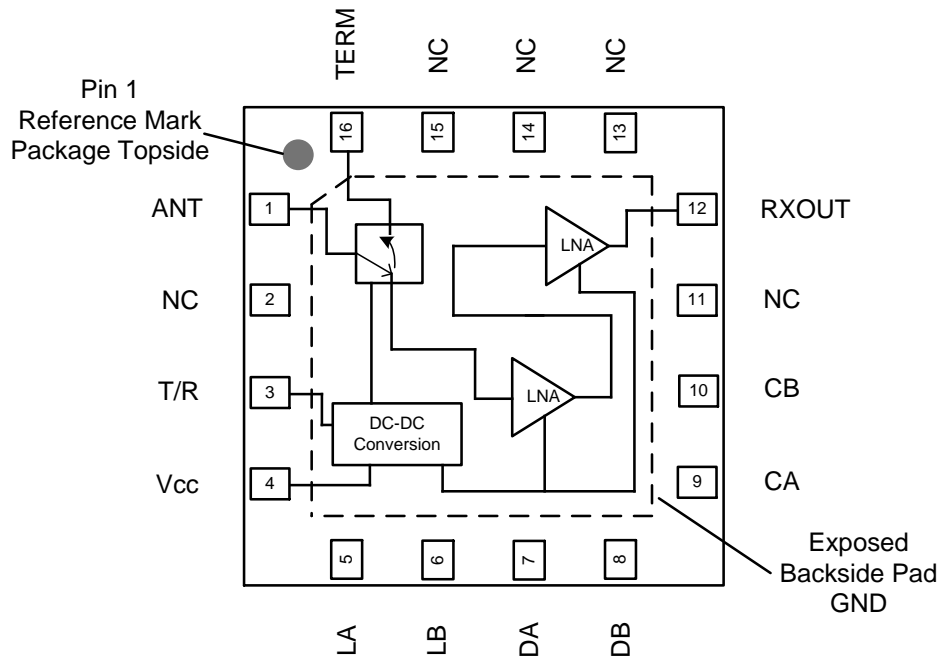

Top View

Pin No.	Label	Description
1	ANT	RF antenna input/output port 50 ohms.
2, 11, 13, 14, 15	NC	No Connection.
3	T/R	Switch Control, Tx mode Low state, Rx mode High state.
4	V _{cc}	DC Power Supply Voltage.
5	LA	External inductor connection for internal power supply.
6	LB	External inductor connection for internal power supply.
7	DA	External diode anode connection for internal power supply.
8	DB	External diode cathode connection for internal power supply.
9	CA	External bypass capacitor connection.
10	CB	External bypass capacitor connection.
12	Rx OUT	RF LNA output port 50 ohms.
16	TERM	RF termination port 50 ohms.
Backside Pad	GND	Ground connection. The back side of the package should be connected to the ground plan though as short of a connection as possible. PCB via holes under the device are required.

Package Marking and Dimensions

Marking: Part number – QPB9320
 Trace Code – Assigned by assembly sub-contractor

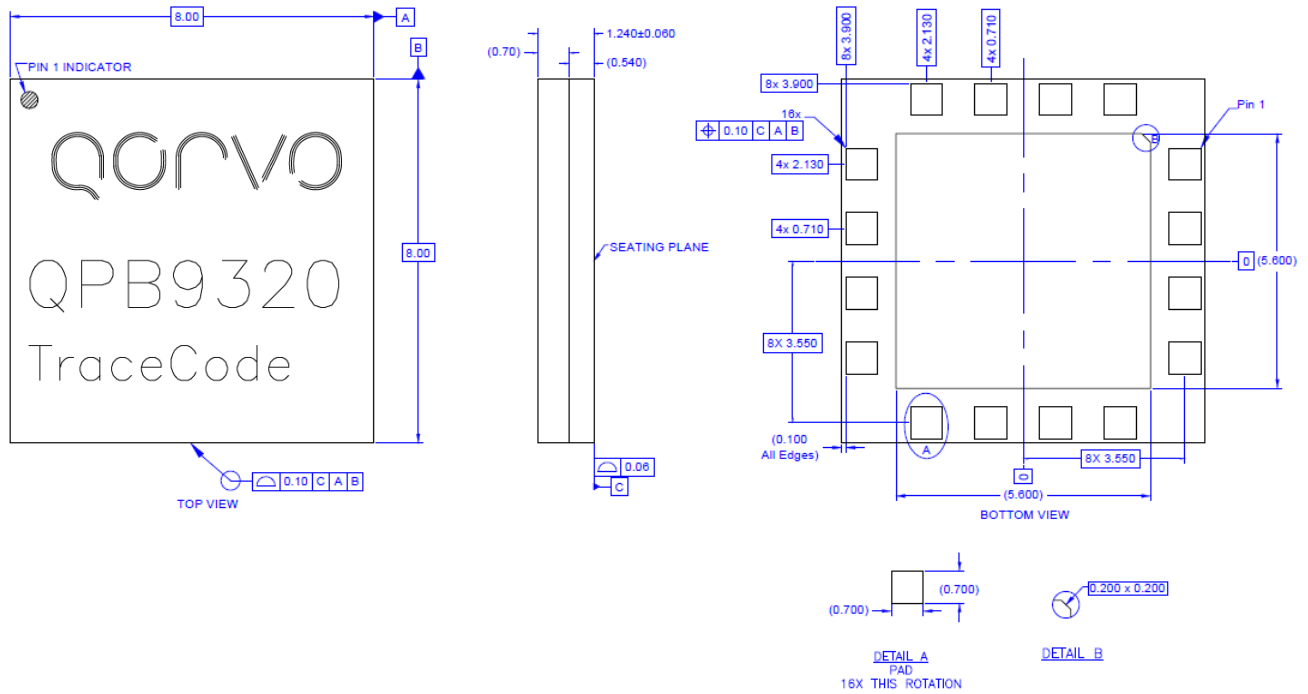

- Notes:
1. All dimensions are in microns. Angles are in degrees.
 2. Dimension and tolerance formats conform to ASME Y14.4M-1994.
 3. The terminal #1 identifier and terminal numbering conform to JESD 95-1 SPP-012.

Handling Precautions

Parameter	Rating	Standard
ESD – Human Body Model (HBM)	Class 1C	ESDA / JEDEC JS-001-2012
ESD – Charged Device Model (CDM)	Class C3	JEDEC JESD22-C101F
MSL – Moisture Sensitivity Level	Level 3	IPC/JEDEC J-STD-020



Caution!
ESD-Sensitive Device

Solderability

Compatible with both lead-free (260°C max. reflow temp.) and tin/lead (245°C max. reflow temp.) soldering processes. Solder profiles available upon request.

Contact plating: Electrolytic plated Au over Ni

RoHS Compliance

This part is compliant with 2011/65/EU RoHS directive (Restrictions on the Use of Certain Hazardous Substances in Electrical and Electronic Equipment) as amended by Directive 2015/863/EU.

This product also has the following attributes:

- Product uses RoHS Exemption 7c-I to meet RoHS Compliance requirements.
- Halogen Free (Chlorine, Bromine)
- Antimony Free
- TBBP-A (C₁₅H₁₂Br₄O₂) Free
- PFOS Free
- SVHC Free

Contact Information

For the latest specifications, additional product information, worldwide sales and distribution locations:

Web: www.qorvo.com

Tel: 1-844-890-8163

Email: customer.support@qorvo.com

For technical questions and application information:

Email: appsupport@qorvo.com

Important Notice

The information contained herein is believed to be reliable; however, Qorvo makes no warranties regarding the information contained herein and assumes no responsibility or liability whatsoever for the use of the information contained herein. All information contained herein is subject to change without notice. Customers should obtain and verify the latest relevant information before placing orders for Qorvo products. The information contained herein or any use of such information does not grant, explicitly or implicitly, to any party any patent rights, licenses, or any other intellectual property rights, whether with regard to such information itself or anything described by such information. **THIS INFORMATION DOES NOT CONSTITUTE A WARRANTY WITH RESPECT TO THE PRODUCTS DESCRIBED HEREIN, AND QORVO HEREBY DISCLAIMS ANY AND ALL WARRANTIES WITH RESPECT TO SUCH PRODUCTS WHETHER EXPRESS OR IMPLIED BY LAW, COURSE OF DEALING, COURSE OF PERFORMANCE, USAGE OF TRADE OR OTHERWISE, INCLUDING THE IMPLIED WARRANTIES OF MERCHANTABILITY AND FITNESS FOR A PARTICULAR PURPOSE.**

Without limiting the generality of the foregoing, Qorvo products are not warranted or authorized for use as critical components in medical, life-saving, or life-sustaining applications, or other applications where a failure would reasonably be expected to cause severe personal injury or death.

Copyright 2018 © Qorvo, Inc. | Qorvo is a registered trademark of Qorvo, Inc.