

General Description

The MAX3736 evaluation kit (EV kit) is an assembled demonstration board that provides complete optical evaluation of the MAX3736 3.3V multirate laser driver.

The EV kit is composed of an optical test circuit. The output of the optical evaluation section is configured for attachment to a laser/monitor diode that is configured in the standard four-lead laser connection on BOSA packages.

Features

- Single +3.3V Power-Supply Operation
- AC-Coupling Provided On-Board
- Allows Optical Evaluation
- Proven PCB Layout
- Fully Assembled and Tested

Ordering Information appears at end of data sheet.

Optical Evaluation Component List

DESIGNATION	QTY	DESCRIPTION
C1, C11, C15, C16, C20	5	0.1µF ±10% ceramic capacitors (0402)
C2–C4	0	Not installed, ceramic capacitors (0402)
C5, C6	2	220pF ±10% ceramic capacitors (0402)*
C7	1	1µF ±10% ceramic capacitor (0805)
C17, C23	2	0.01µF ±5% ceramic capacitors (0402)
D1	0	Not installed, user-supplied laser
J1, J2	2	SMA connectors, tab contact
J8, J10, TP1–TP10	12	Test points
JU1, JU2, JU13	3	2-pin headers, 0.1in centers
L1, L3	2	Ferrite beads (0402) Murata BLM15HG102

DESIGNATION	QTY	DESCRIPTION
R1, R2	2	1.5kΩ ±5% resistors (0402)
R3	1	75Ω ±5% resistor (0402)*
R4, R18	2	1.0kΩ ±1% resistors (0402)
R15, R17	2	20kΩ variable resistors
R21	1	10Ω ±5% resistor (0402)
R22	1	24Ω ±5% resistor (0402)*
R23	1	15Ω ±5% resistor (0402)
U2	1	3.3V multirate laser driver (16 TQFN-EP*) Maxim MAX3736ETE+
—	3	Shunts
—	1	PCB: MAX3736 EVALUATION KIT REV C

*EP = Exposed pad.

*These components are part of the compensation network, which can reduce overshoot and ringing. Ringing due to parasitic series inductance of the laser can be eliminated with R22/R3 and C6/C5. Starting values for most coaxial lasers is R3 = 75Ω in series with C5 = 220pF and R22 = 24Ω in series with C6 = 220pF. These values should be experimentally adjusted until the optical eye diagram is optimized.

Component Supplier

SUPPLIER	PHONE	WEBSITE
Murata Electronics North America, Inc.	770-436-1300	www.murata-northamerica.com

Note: Indicate that you are using the MAX3736 when contacting this component supplier.



QuickStart

Procedure

For optical evaluation of the device, configure the EV kit as follows:

- 1) To enable the outputs, connect DIS to GND by placing a shunt across jumper JU13.
- 2) The EV kit is designed to allow connection to a typical BOSA-packaged laser. Connect the laser with monitor diode (Figure 1) as follows:
 Keeping its leads as short as possible, connect the laser diode to the appropriate pads in the cut-out portion on the top (component) side of the PCB.
Note: When performing the following resistance checks, manually set the ohmmeter to a high range to avoid forward biasing the on-chip ESD protection diodes.
- 3) Adjust R17, the R_{MODSET} potentiometer, for maximum resistance (≈20kΩ) between TP7 and ground. This sets the modulation current to a low value (< 10mA). Refer to the *Design Procedure* section in the MAX3736 IC data sheet.
- 4) Apply a differential input signal (200mV_{P-P} to 2400mV_{P-P}) between SMA connectors J1 and J2 (IN+ and IN-).
- 5) Attach the laser diode fiber connector to an optical-to-electrical converter.

- 6) Connect a 3.3V supply between J8 (V_{CC}) and J10 (GND). Set the current limit to 200mA and power on the device.
- 7) Adjust R15 (R_{BIASSET}) until the desired average optical power is achieved.
- 8) The BIAS current can be monitored at TP8 (V_{BC_MON}) using the following equation:

$$I_{BIAS} = \frac{V_{BC_MON}}{1000\Omega} \times 85$$

Note: If the voltage at TP8 exceeds 1.39V, the BC_MON pin goes out of regulation.

- 9) Adjust R17 (R_{MODSET}) until the desired optical amplitude is achieved. Optical amplitude can be observed on an oscilloscope connected to an optical-to-electrical converter. Laser overshoot and ringing can be improved by appropriate selection of R3, R21–R23, C5, and C6, as described in the *Design Procedure* section in the MAX3736 IC data sheet.
Note: External DACs can be used to control the bias and modulation current. To do this, remove shunts from jumpers JU1 and JU2 to disconnect potentiometers R15 (R_{BIASSET}) and R17 (R_{MODSET}). Connect the DAC outputs to TP6 (BIASSET) and TP7 (MODSET).

Table 1. Adjustment and Control Descriptions (see the Quick Start section first)

DESIGNATION	NAME	DESCRIPTION
JU13	DIS	Enables/disables the output currents. Active low (shunt across JU13 to enable output currents).
R15	R _{BIASSET}	Adjusts the bias current.
R17	R _{MODSET}	Adjusts the laser modulation current.
TP8	BC_MON	TP8 offers a connection to probe the BC_MON current through a 1kΩ resistor to ground. This allows the bias current to be determined as I _{BIAS} = V _{BC_MON} /1000Ω x 85.
TP9	BIAS	TP9 allows the voltage at the BIAS pin to be monitored.
TP10	MD	TP10 offers a connection to probe the monitor diode current through a 1kΩ resistor to ground. The current can be determined as I _{MD} = V _{MD} /1000Ω.

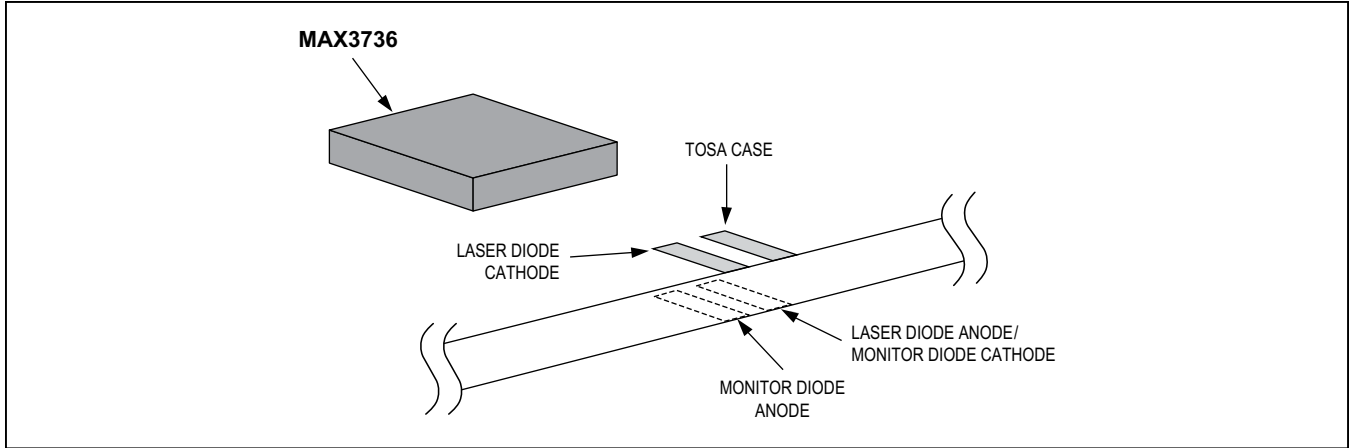

Figure 1. Attachment of Packaged Laser to the MAX3736 EV Kit

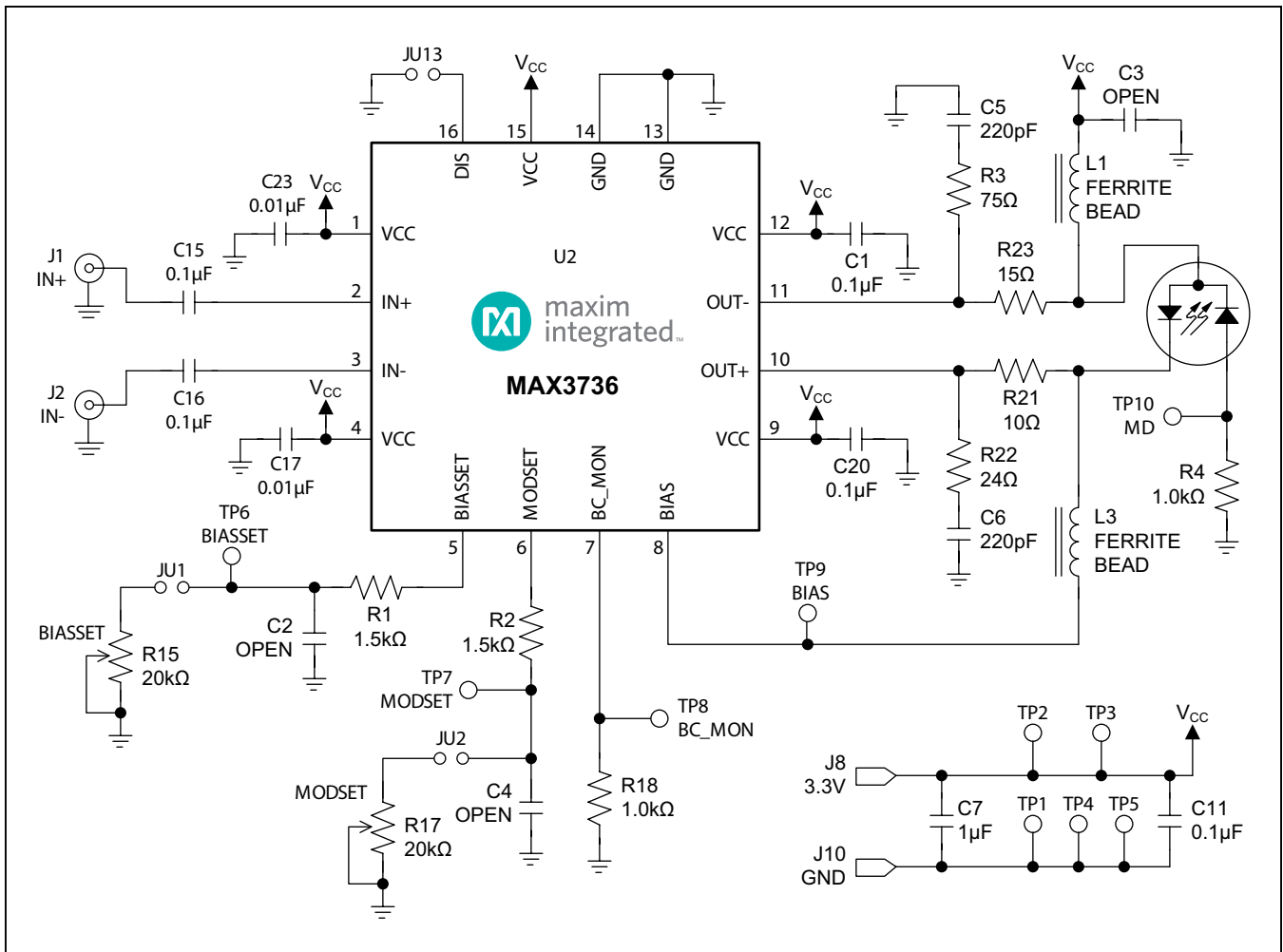

Figure 2. MAX3736 EV Kit Schematic

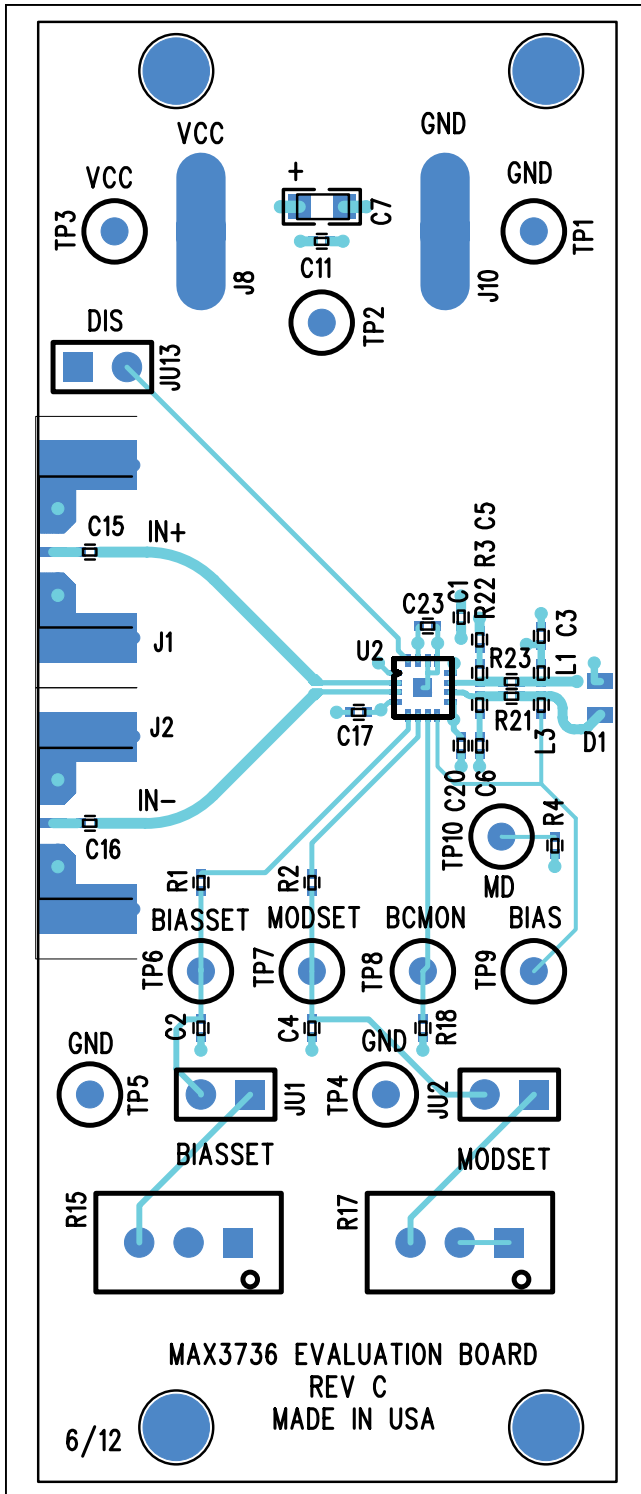

Figure 3. MAX3736 EV Kit Component Placement Guide—Component Side

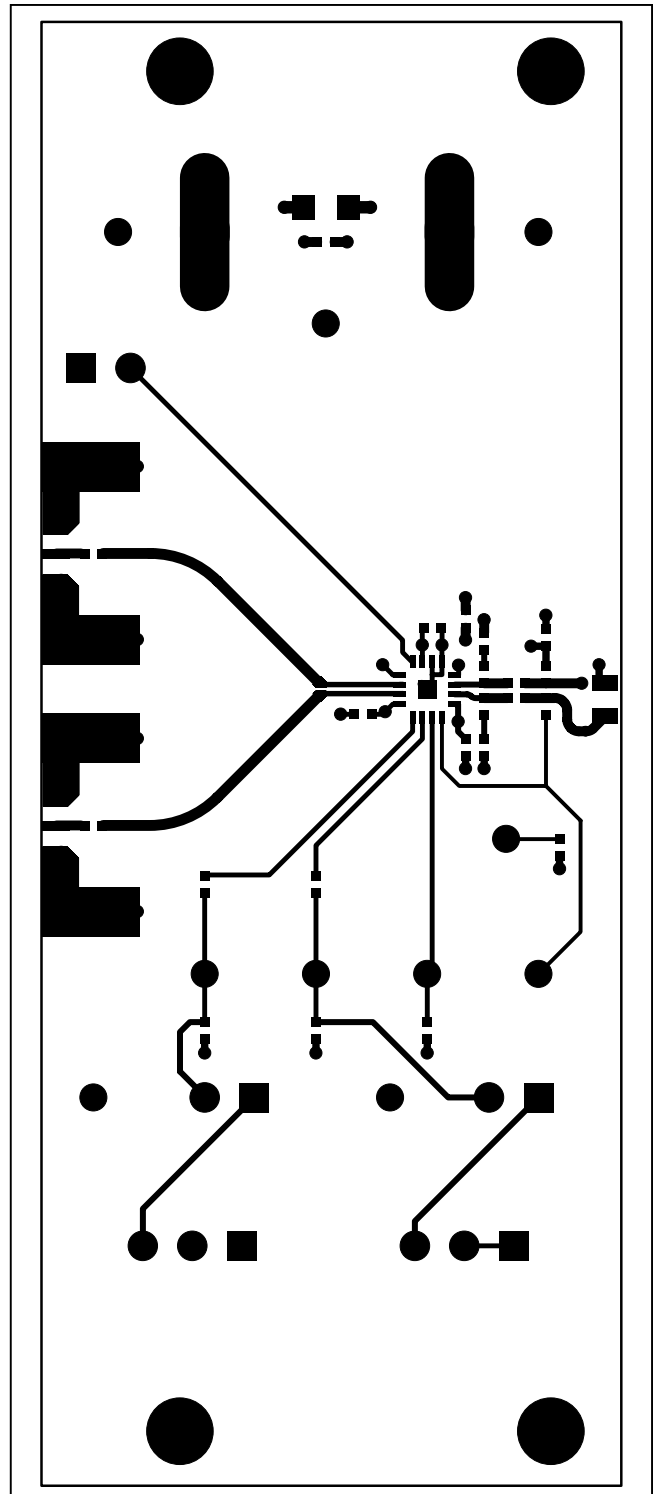

Figure 4. MAX3736 EV Kit PCB Layout—Component Side

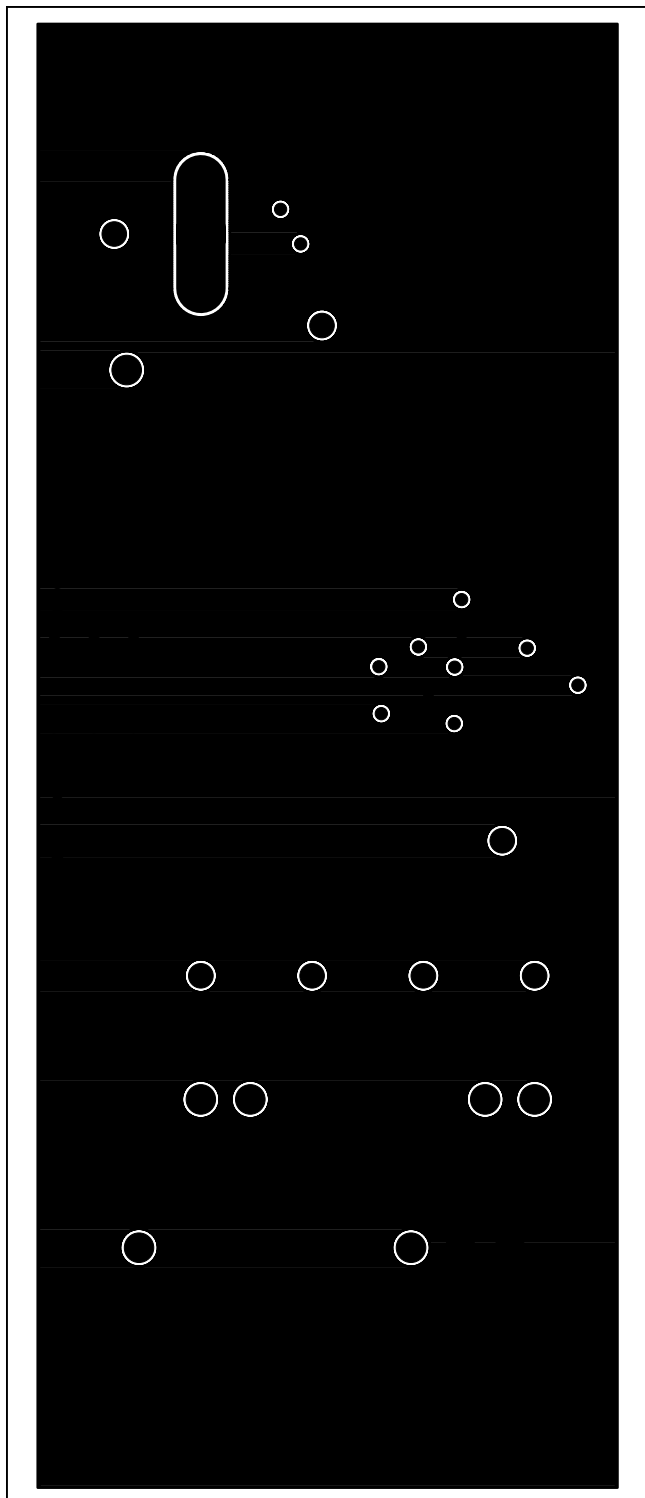

Figure 5. MAX3736 EV Kit PCB Layout—Ground Plane

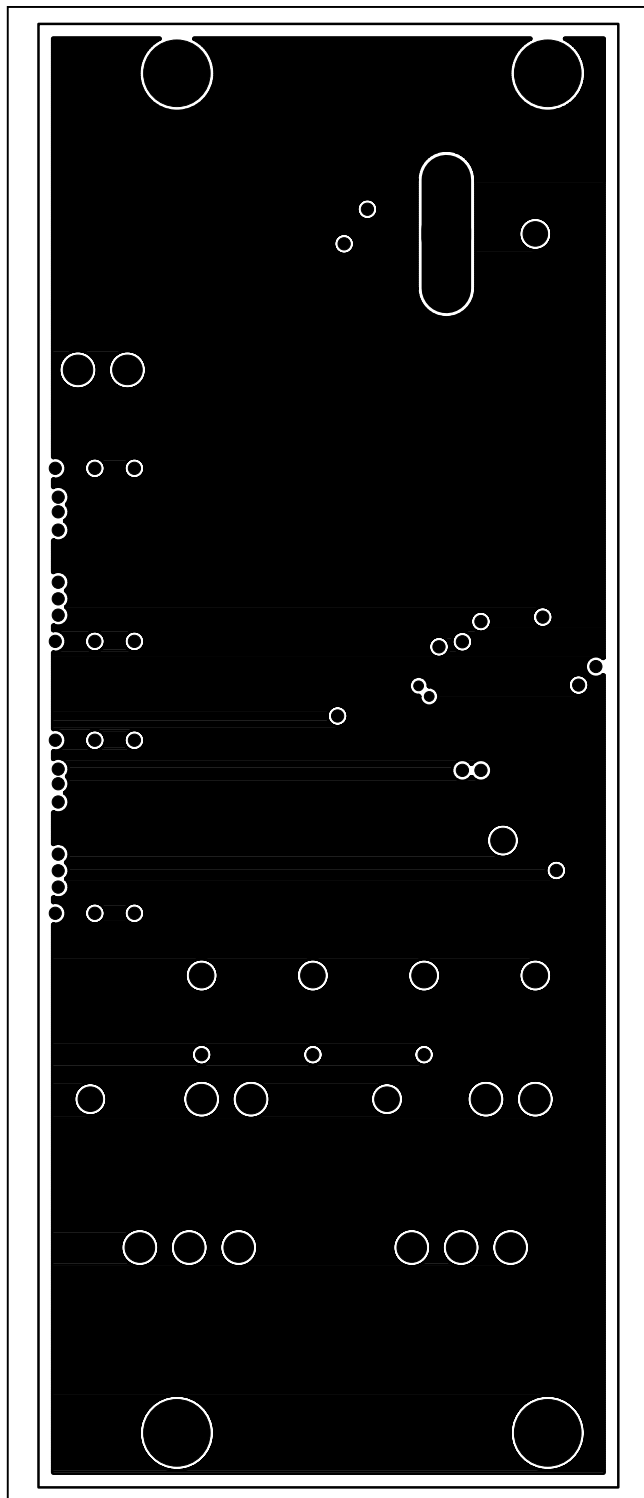

Figure 6. MAX3736 EV Kit PCB Layout—Power Plane

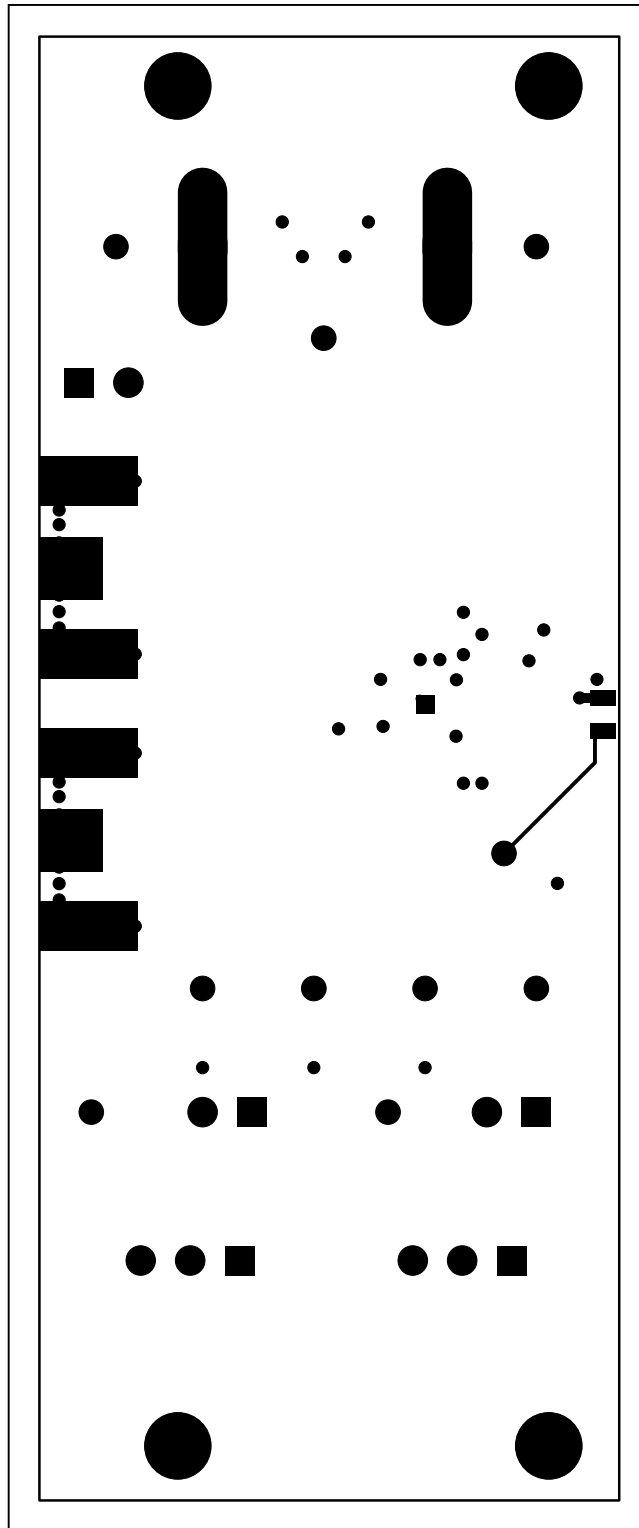

Figure 7. MAX3736 EV Kit PCB Layout—Solder Side

Ordering Information

PART	TYPE
MAX3736EVKIT	EV Kit

Revision History

REVISION NUMBER	REVISION DATE	DESCRIPTION	PAGES CHANGED
0	11/12	Initial release	—

For pricing, delivery, and ordering information, please contact Maxim Direct at 1-888-629-4642, or visit Maxim Integrated's website at www.maximintegrated.com.

Maxim Integrated cannot assume responsibility for use of any circuitry other than circuitry entirely embodied in a Maxim Integrated product. No circuit patent licenses are implied. Maxim Integrated reserves the right to change the circuitry and specifications without notice at any time.