

THIS DRAWING IS UNPUBLISHED. RELEASED FOR PUBLICATION 20
 © COPYRIGHT 20 BY - ALL RIGHTS RESERVED.

REVISIONS					
P	LTR	DESCRIPTION	DATE	DWN	APVD
	A	INITIAL RELEASE	29NOV2016	YC	CW

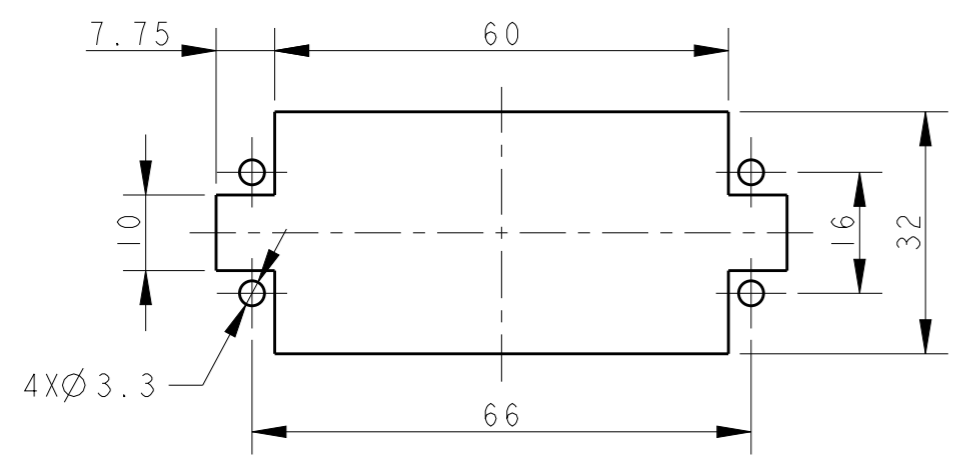
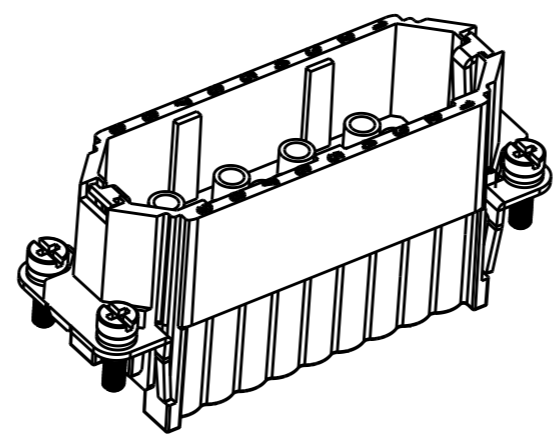
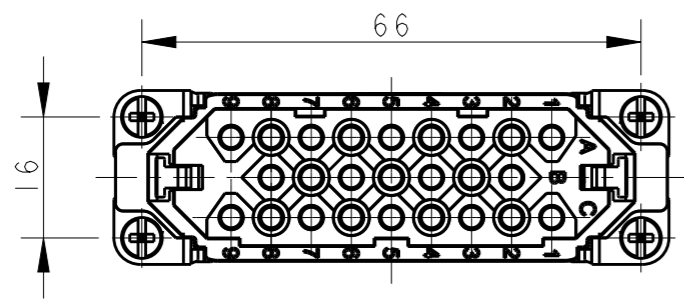
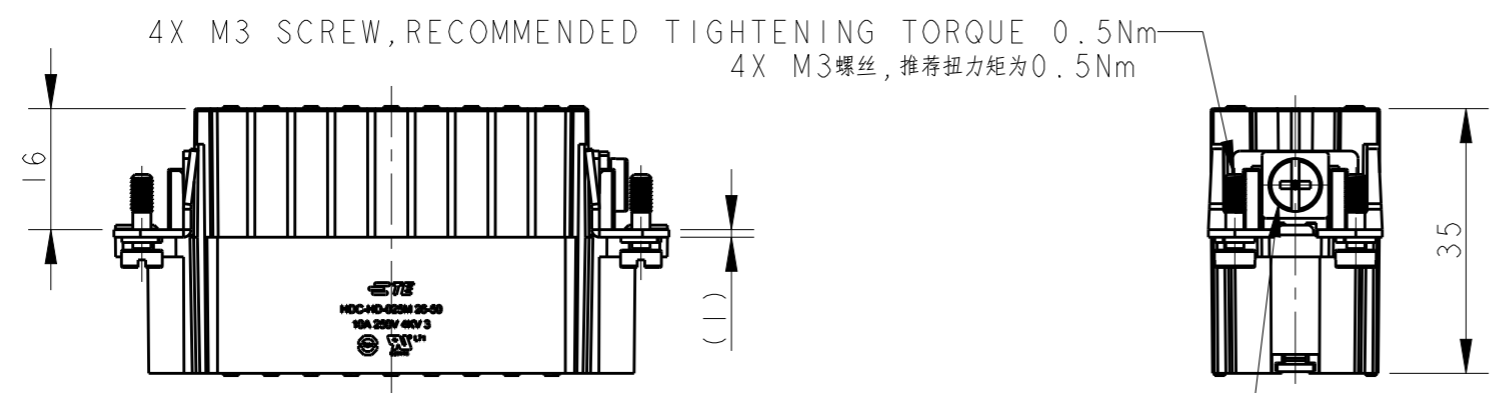
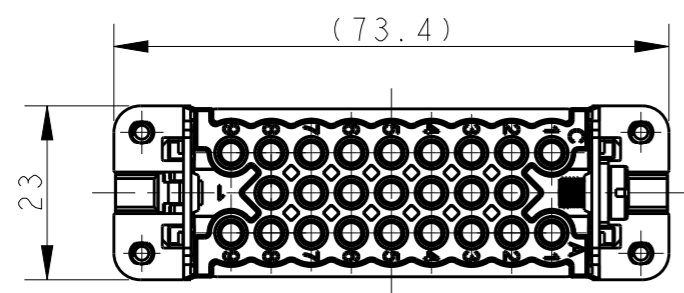

PANEL CUT OUT DIMENSION FOR INSERT WITHOUT HOODS/HOUSING, ONLY FOR REFERENCE
 不使用防护外壳时芯件的开孔安装尺寸, 仅供参考

- NOTES:
- TECHNICAL CHARACTERISTICS:
 INSULATION MATERIAL: PC
 RATED VOLTAGE: 250 V
 RATED CURRENT: 10 A
 INSULATION RESISTANCE: $\geq 400M\Omega$
 RATED IMPULSE VOLTAGE: 4 KV
 POLLUTION DEGREE: 3
 FLAMMABILITY: UL94V-0
 MATING CYCLES: 500 CYCLES
 WIRE RANGE: 0.14-2.5 mm² (26-14 AWG)
 CONTACT TYPE: CRIMP CONTACT
 - CONTACT NEED TO BE ORDERED SEPARATELY.
 (ORDER No. REFER TO DRAWING: T20200X10XX000)

- 注释:
- 技术参数:
 绝缘材料: PC
 额定电压: 250V
 额定电流: 10A
 绝缘电阻: $\geq 400M\Omega$
 额定脉冲电压: 4 KV
 污染等级: 3
 阻燃等级: UL94V-0
 插拔次数: 500次
 接线范围: 0.14-2.5 mm² (26-14 AWG)
 接线类型: 冷压接
 - 端子需要单独订购.
 (订货号参考图面: T20200X10XX000)

T2020502101-000	HD-025-M 26-50	HD-025 MALE INSERT 26-50 HD-025 公插 26-50
PART NUMBER 料号	PART DESCRIPTION 描述	

THIS DRAWING IS A CONTROLLED DOCUMENT.	
DIMENSIONS: mm	TOLERANCES UNLESS OTHERWISE SPECIFIED: 0 PLC ±- 1 PLC ±- 2 PLC ±- 3 PLC ±- 4 PLC ±- ANGLES ±-
MATERIAL	FINISH

DWN YORK CHEN 29NOV2016	TE Connectivity NAME HD-025-M 26-50			
CHK KYLE ZENG 29NOV2016				
APVD CHRIS WANG 29NOV2016				
PRODUCT SPEC 108-137042				
APPLICATION SPEC 114-137042	SIZE A3	CAGE CODE 00779	DRAWING NO T2020502101000	RESTRICTED TO -
CUSTOMER DRAWING	SCALE 1:1	SHEET 1	OF 1	REV A