

THIS DRAWING IS UNPUBLISHED. RELEASED FOR PUBLICATION 20  
 © COPYRIGHT 20 BY - ALL RIGHTS RESERVED.

REVISIONS					
P	LTR	DESCRIPTION	DATE	DWN	APVD
	A	INITIAL RELEASE	06APR2015	GY	CW
	B	ECR-15-013759	29SEP2015	DW	CW

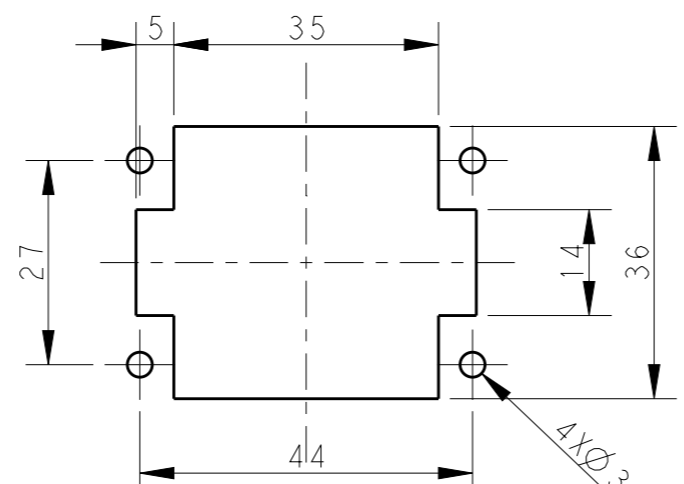
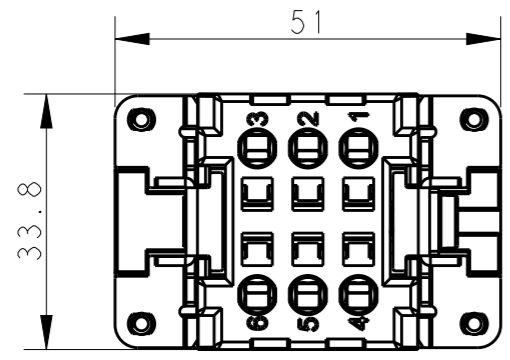

4 X M3 screw,  
recommended tightening  
torque 0.5Nm

不使用防护外壳时芯件的安装开孔图  
Panel cut out for inserts for  
use without hoods/housings

NOTES:  
 1. TECHNICAL CHARACTERISTICS:  
 INSULATION MATERIAL: PC  
 RATED VOLTAGE: 500V  
 RATED CURRENT: 16A  
 INSULATION RESISTANCE:  $\geq 400M\Omega$   
 RATED IMPULSE VOLTAGE: 6KV  
 POLLUTION DEGREE: 3  
 FLAMMABILITY: UL94V-0  
 MATING CYCLES: 500 CYCLES  
 OPERATION TEMPERATURE:  $-40^{\circ}C \sim +125^{\circ}C$   
 WIRE RANGE:  $0.5mm^2 \sim 2.5mm^2$  (AWG20-AWG14)  
 CONTACT TYPE: SPRING CLAMP

注释:  
 1. 技术参数:  
 绝缘材料: PC  
 额定电压: 500V  
 额定电流: 16A  
 绝缘电阻:  $\geq 400M\Omega$   
 脉冲电压: 6KV  
 污染等级: 3  
 阻燃等级: UL94V-0  
 插拔次数: 500 次  
 工作温度:  $-40^{\circ}C \sim +125^{\circ}C$   
 接线范围:  $0.5mm^2 \sim 2.5mm^2$  (AWG20-AWG14)  
 接线类型: 弹片压接

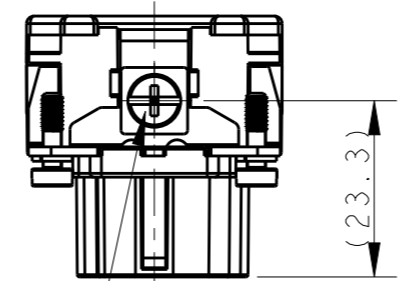
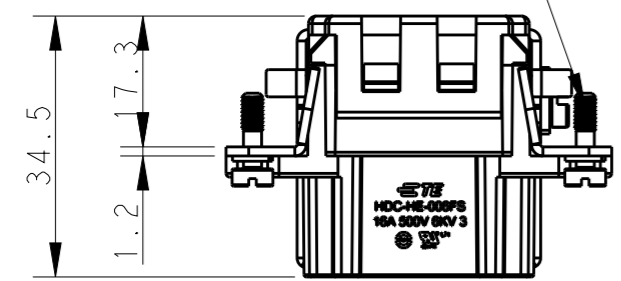

M4 screw, recommended  
tightening torque 1.2Nm

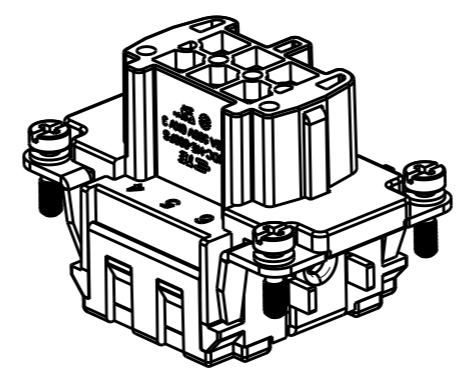
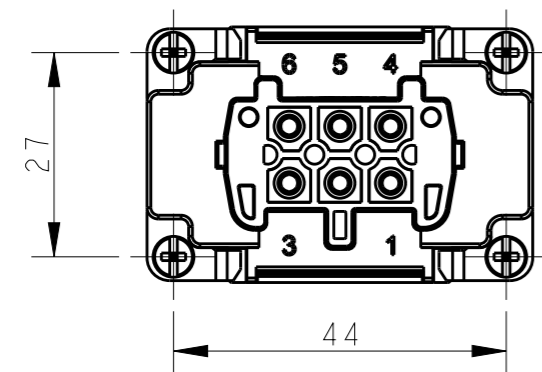

HE-006-FS	T2040063201-000
DESCRIPTION	PART NUMBER

THIS DRAWING IS A CONTROLLED DOCUMENT.		DWN	Gino.Yao	06APR2015	 TE Connectivity NAME HE-006-FS				
DIMENSIONS:		CHK	Chris.Wang	06APR2015					
mm		APVD	Xiang.Xu	06APR2015					
TOLERANCES UNLESS OTHERWISE SPECIFIED:		PRODUCT SPEC	108-137044						
0 PLC $\pm$ 1 PLC $\pm$ 2 PLC $\pm$ 3 PLC $\pm$ 4 PLC $\pm$ ANGLES $\pm$		APPLICATION SPEC	114-137044		SIZE	CAGE CODE	DRAWING NO	RESTRICTED TO	
MATERIAL		WEIGHT	-		A3	00779	©-T2040063201000	-	
FINISH		Customer Drawing		SCALE	1:1	SHEET	1 OF 1	REV	B