

Free Standing Connector Mounted Card Guides

Secure connection, rugged support of 0.062" thick PCB's when space is limited. P/N BR27D is die cast of zinc alloy#3 (ASTM B240-06). Other sizes are 6063 T5 aluminum alloy. All sizes include HD55 hardware kit to attach connector to board. Connector not included (See Page 70). All sold as a pair and are fully RoHS compliant.

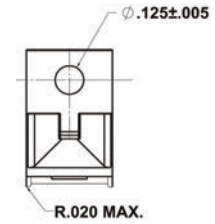
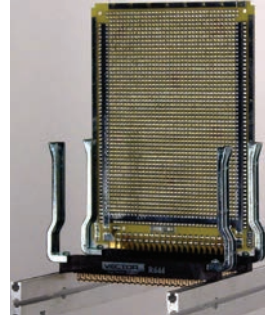

Part No.	Use With Connector	For Use With	Material
BR27D	R644, R644-2, R644-3C, R644-3F	4.5"W (3677, 3682 & 3662 series), Page 57	Zinc #3
BR27-1	R636-1, R636-2	4.5"W (3719 series), Page 58	Al Alloy 6063 T5
BR27-3	R630	2.73"W (3797 series), Page 56	Al Alloy 6063 T5
BR27-5	R656-1, R656-2	4.5"W (4610 series), Page 63	Al Alloy 6063 T5

BR27D Zinc die-cast model shown

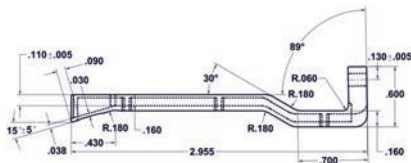

8 7 6 5 4 3 2 1

REVISIONS				
ZONE	REV.	DESCRIPTION	DATE	APPROVED
ALL	F		01/08/09	

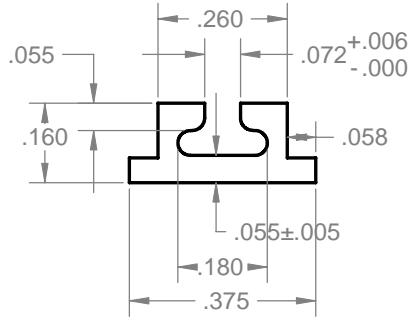

SECTION K-K
SCALE 4:1

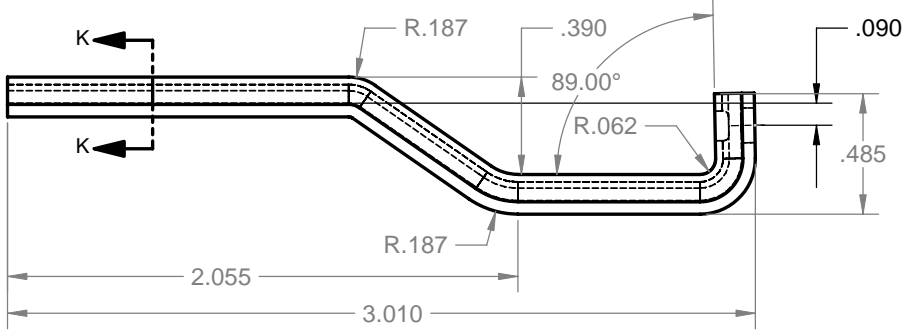
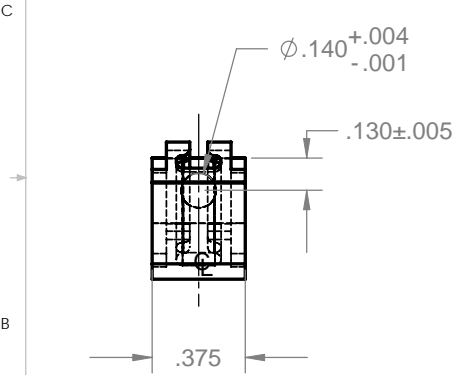
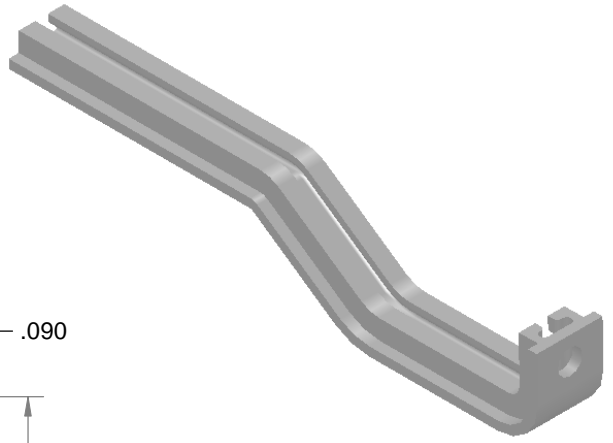
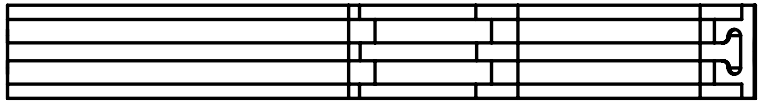

4. PARTS TO BE DEGREASED AFTER FABRICATION
 3. PARTS TO BE FREE OF EXCESSIVE BURRS AND SURFACE SCRATCHES
 2. FINISH: CLEAR ANODIZE
 1. MATERIAL: ALUM. EXTRUSION 6063-T5
- NOTES: UNLESS OTHERWISE SPECIFIED.

PROPRIETARY AND CONFIDENTIAL
 THE INFORMATION CONTAINED IN THIS DRAWING IS THE SOLE PROPERTY OF VECTOR ELECTRONICS & TECH., INC. ANY REPRODUCTION IN PART OR AS A WHOLE WITHOUT THE WRITTEN PERMISSION OF VECTOR ELECTRONICS & TECH., INC. IS PROHIBITED.

UNLESS OTHERWISE SPECIFIED:		NAME	DATE	VECTOR ELECTRONICS & TECHNOLOGY, INC. CA 91605	11115 VANOWEN ST., NORTH HOLLYWOOD, CA 91605	
DIMENSIONS ARE IN INCHES TOLERANCES: FRACTIONAL ± ANGULAR: ±5° TWO PLACE DECIMAL ±.03 THREE PLACE DECIMAL ±.010 INTERPRET GEOMETRIC TOLERANCING PER:		DRAWN	TRUSHAR		01/08/09	CARD GUIDE BR27-3
MATERIAL 1		CHECKED				
FINISH 2		ENG APPR.				
DO NOT SCALE DRAWING		MFG APPR.				
		Q.A.			SIZE DWG. NO.	
		THIRD ANGLE PROJECTION			REV	
					B M5474-1-8 F	
					SCALE: 1:1 WEIGHT: SHEET 1 OF 1	

8 7 6 5 4 3 2 1

8 7 6 5 4 3 2 1

REVISIONS				
ZONE	REV.	DESCRIPTION	DATE	APPROVED
ALL	F		01/08/09	

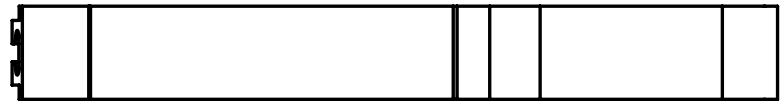
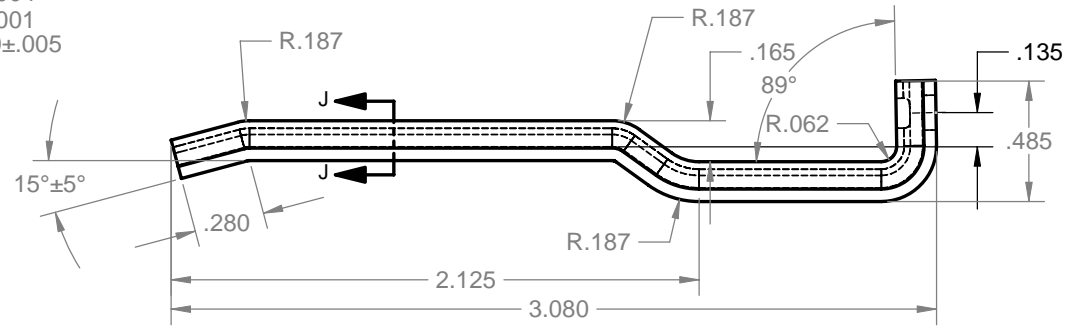
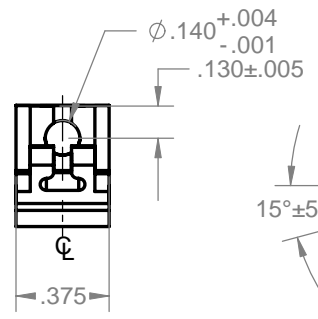
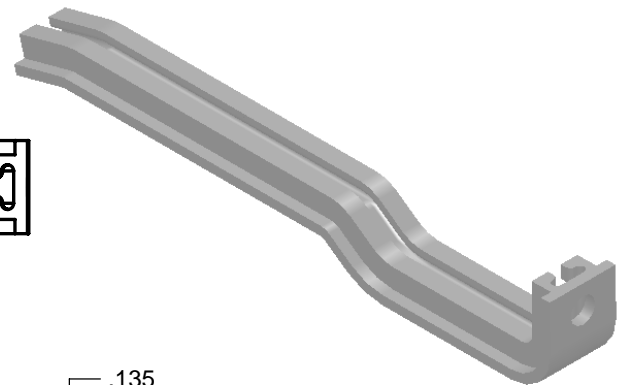
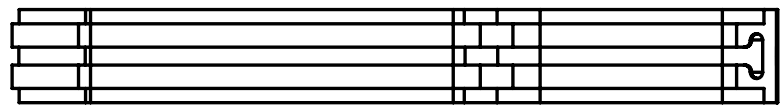
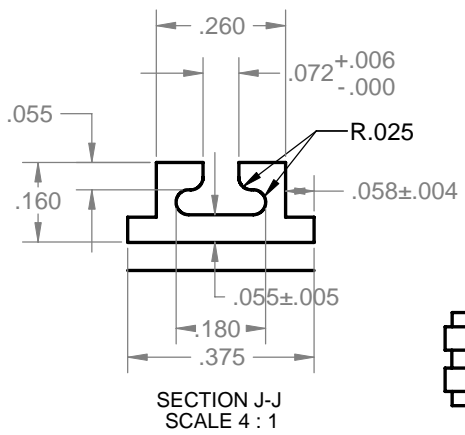

4. PARTS TO BE DEGREASED AFTER FABRICATION
 3. PARTS TO BE FREE OF EXCESSIVE BURRS AND SURFACE SCRATCHES
 2. FINISH: CLEAR ANODIZE
 1. MATERIAL: ALUM. EXTRUSION 6063-T5
- NOTES: UNLESS OTHERWISE SPECIFIED.

PROPRIETARY AND CONFIDENTIAL
 THE INFORMATION CONTAINED IN THIS DRAWING IS THE SOLE PROPERTY OF VECTOR ELECTRONICS & TECH., INC. ANY REPRODUCTION IN PART OR AS A WHOLE WITHOUT THE WRITTEN PERMISSION OF VECTOR ELECTRONICS & TECH., INC. IS PROHIBITED.

UNLESS OTHERWISE SPECIFIED:
 DIMENSIONS ARE IN INCHES
 TOLERANCES:
 FRACTIONAL ±
 ANGULAR: ±5°
 TWO PLACE DECIMAL ±.03
 THREE PLACE DECIMAL ±.010
 INTERPRET GEOMETRIC TOLERANCING PER:
 MATERIAL **1**
 FINISH **2**
 DO NOT SCALE DRAWING

NAME	DATE
DRAWN TRUSHAR	01/08/09
CHECKED	
ENG APPR.	
MFG APPR.	
Q.A.	

VECTOR ELECTRONICS & TECHNOLOGY, INC. 11115 VANOWEN ST., NORTH HOLLYWOOD, CA 91605

CARD GUIDE BR27-1

SIZE DWG. NO. **B M5474-1-5** REV **F**

SCALE: 1:1 WEIGHT: SHEET 1 OF 1



8 7 6 5 4 3 2 1

8 7 6 5 4 3 2 1

REVISIONS				
ZONE	REV.	DESCRIPTION	DATE	APPROVED
ALL	F		01/08/09	

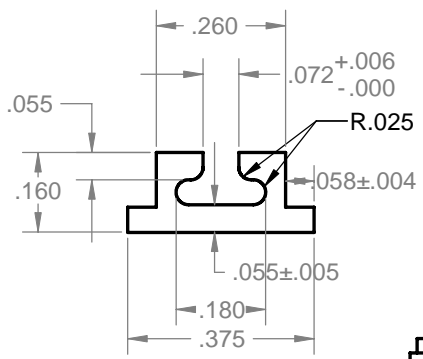

SECTION K-K
SCALE 4 : 1

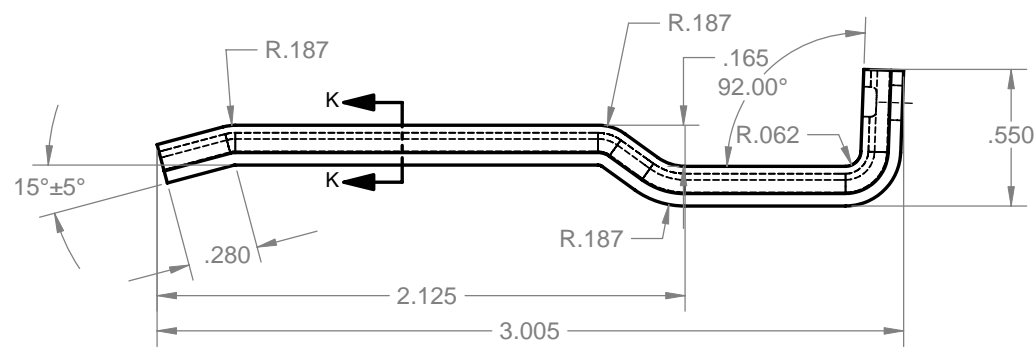
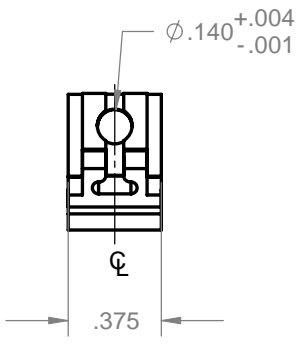
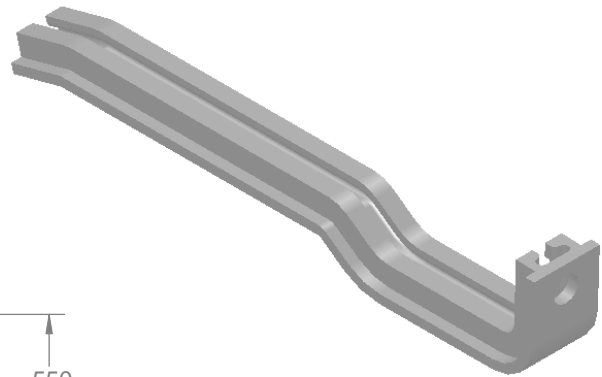

- 4. PARTS TO BE DEGREASED AFTER FABRICATION
- 3. PARTS TO BE FREE OF EXCESSIVE BURRS AND SURFACE SCRATCHES
- 2. FINISH: CLEAR ANODIZE
- 1. MATERIAL: ALUM. EXTRUSION 6063-T5

NOTES: UNLESS OTHERWISE SPECIFIED.

PROPRIETARY AND CONFIDENTIAL
THE INFORMATION CONTAINED IN THIS DRAWING IS THE SOLE PROPERTY OF VECTOR ELECTRONICS & TECH., INC. ANY REPRODUCTION IN PART OR AS A WHOLE WITHOUT THE WRITTEN PERMISSION OF VECTOR ELECTRONICS & TECH., INC. IS PROHIBITED.

UNLESS OTHERWISE SPECIFIED:
DIMENSIONS ARE IN INCHES
TOLERANCES:
FRACTIONAL ±
ANGULAR: ±5°
TWO PLACE DECIMAL ±.03
THREE PLACE DECIMAL ±.010
INTERPRET GEOMETRIC TOLERANCING PER:
MATERIAL **1**
FINISH **2**
DO NOT SCALE DRAWING

NAME	DATE
DRAWN TRUSHAR	01/08/09
CHECKED	
ENG APPR.	
MFG APPR.	
Q.A.	

VECTOR 11115 VANOWEN ST., NORTH HOLLYWOOD, CA 91605
ELECTRONICS & TECHNOLOGY, INC.

CARD GUIDE
BR27-5

SIZE DWG. NO. REV
B M5474-1-12 **F**

SCALE: 1:1 WEIGHT: SHEET 1 OF 1



8 7 6 5 4 3 2 1