

Jul.1.2019 Copyright 2019 HIROSE ELECTRIC CO., LTD. All Rights Reserved.
 In case of consideration for using Automotive equipment / device which demand high reliability, kindly contact our sales window correspondents.

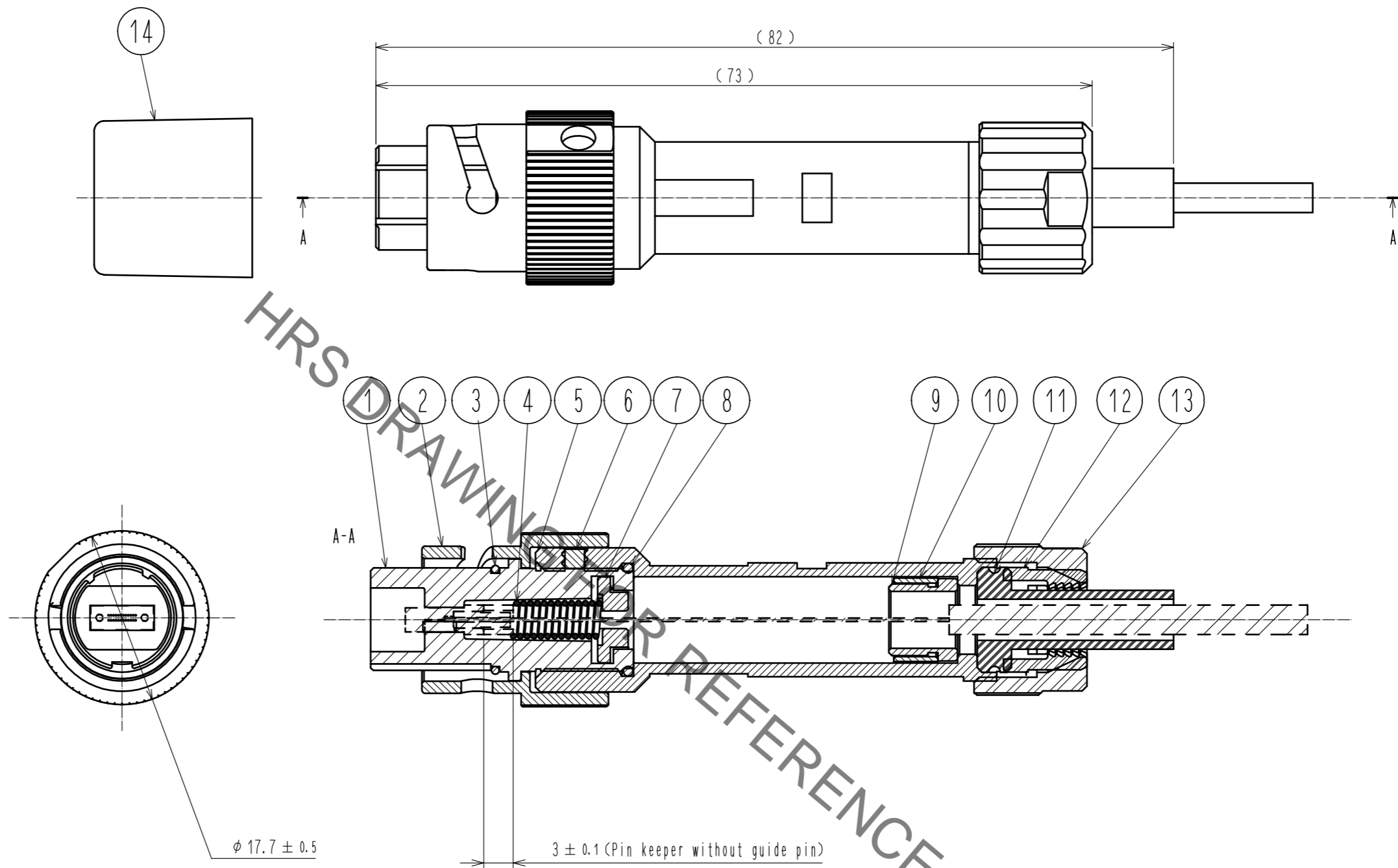

Note 1. FO cable and MT ferrule are NOT included in this product.
 2. Use specific tool to assemble this product.

\triangle Depends on system

NO.	MATERIAL	FINISH . REMARKS	NO.	MATERIAL	FINISH . REMARKS
7	Zinc alloy die casting	Ni Plating	14	Elastomer	Black
6	Stainless steel	—	13	PPS	Blown
5	Zinc alloy die casting	Ni Plating	12	PA	White
4	Stainless steel	For 24 fibers: Spring force 2kgf	11	Silicone rubber	Black
3	Silicone rubber	Red	10	Brass	Ni plating
2	Zinc alloy die casting	Ni plating	9	Brass	Ni plating
1	Zinc alloy die casting	Ni Plating	8	Silicon rubber	Red

UNITS	SCALE	COUNT	DESCRIPTION OF REVISIONS	DESIGNED	CHECKED	DATE
mm	2 : 1	1	DIS-K-00001131	TY. SATO	FS. YOSHIDA	17. 07. 04

APPROVED : MT. SHIBUTANI	15. 05. 08	DRAWING NO.	EDC-179477-00-00
CHECKED : YY. HIYAMA	15. 05. 08	PART NO.	MF11BMT-WP4CB01
DESIGNED : TY. SATO	15. 05. 08	CODE NO.	CL709-7003-0-00
DRAWN : TY. SATO	15. 05. 08		