

## Main

Range of product	OsiSense XU
Series name	Application food and beverage
Electronic sensor type	Photo-electric sensor
Sensor name	XU1
Sensor design	Cylindrical M18
Detection system	Reflex
Material	Stainless steel
Line of sight type	90° lateral
Type of output signal	Discrete
Supply circuit type	DC
Wiring technique	3-wire
Discrete output type	PNP
Discrete output function	1 NO or 1 NC programmable
Electrical connection	Cable
Cable length	6.56 ft (2 m)
Product specific application	-
Emission	Infrared reflex
[Sn] nominal sensing distance	13.12 ft (4 m) reflex need reflector XUZC50

## Complementary

Enclosure material	Stainless steel : 304 CU
Lens material	PMMA
Maximum sensing distance	18.04 ft (5.5 m) with reflector 50 x 50 mm
Output type	Solid state
Add on output	Without
Add on input	Programmation
Cable composition	4 x 0.34 mm <sup>2</sup>
Wire insulation material	PvR
Cable outer diameter	0.17 in (4.2 mm)
Status LED	1 LED (green) supply on 1 LED (yellow) output state
[Us] rated supply voltage	12...24 V DC with reverse polarity protection
Supply voltage limits	10...30 V DC
Switching capacity in mA	<= 100 mA (overload and short-circuit protection)
Switching frequency	<= 500 Hz
Voltage drop	<= 1.5 V (closed state)
Current consumption	<= 30 mA (no-load)
Delay first up	<= 15 ms
Delay response	<= 1 ms
Delay recovery	<= 1 ms
Setting-up	Without sensitivity adjustment
Diameter	0.71 in (18 mm)
Length	3.07 in (78 mm)
Product weight	0.34 lb(US) (0.155 kg)
Kit composition	Sensor Reflector XUZC50

## Environment

product certifications	CE CSA UL
ambient air temperature for operation	-13...131 °F (-25...55 °C)
ambient air temperature for storage	-40...158 °F (-40...70 °C)
vibration resistance	25 gn, amplitude = +/- 1.5 mm (f = 10...55 Hz) conforming to IEC 60068-2-6
shock resistance	30 gn (duration = 11 ms) conforming to IEC 60068-2-27
IP degree of protection	IP67 conforming to IEC 60529

## Offer Sustainability

Not Green Premium product	Not Green Premium product
Will be Compliant on 3Q2013	Will be Compliant on 3Q2013 Will be Compliant on 3Q2013
Available	Available
Available	Available
WARNING: This product can expose you to chemicals including:	WARNING: This product can expose you to chemicals including:
Diisononyl phthalate (DINP), which is known to the State of California to cause cancer, and	Diisononyl phthalate (DINP), which is known to the State of California to cause cancer, and
Di-isodecyl phthalate (DIDP), which is known to the State of California to cause birth defects or other reproductive harm.	Di-isodecyl phthalate (DIDP), which is known to the State of California to cause birth defects or other reproductive harm.
For more information go to <a href="http://www.p65warnings.ca.gov">www.p65warnings.ca.gov</a>	For more information go to <a href="http://www.p65warnings.ca.gov">www.p65warnings.ca.gov</a>

## Contractual warranty

Warranty period	18 months
-----------------	-----------

## Dimensions

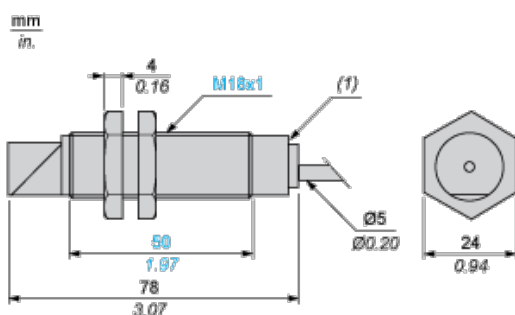

(1) LED

## Mounting and Clearance

Fixing nut tightening torque: < 15 N.m

Connector tightening torque: 2 N.m

## Wiring Schemes

### 3-wire, PNP NO or NC Programmable Function

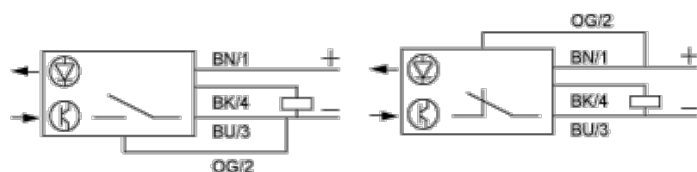

BN : Brown

BK : Black (out / output)

BU : Blue

OG : Orange (program)

## Detection Curves

### Reflex System with Reflector XUZC50

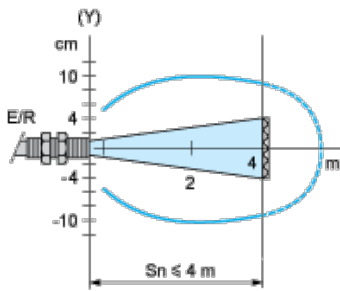

(y)  $\varnothing$  of beam

## Excess Gain Curves (Ambient Temperature: + 25° C)

### Reflex System with Reflector XUZC50

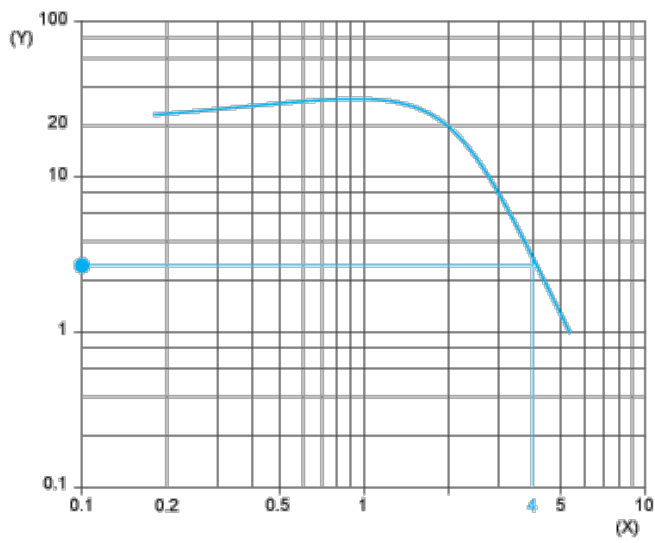

(y) Gain

(x) Distance (m)