



128K x36/32 and 256K x18 4Mb, ECC, SYNCHRONOUS FLOW-THROUGH SRAM

FEBRUARY 2015

FEATURES

- Internal self-timed write cycle
- Individual Byte Write Control and Global Write
- Clock controlled, registered address, data and control
- Burst sequence control using MODE input
- Three chip enable option for simple depth expansion and address pipelining
- Common data inputs and data outputs
- Auto Power-down during deselect
- Single cycle deselect
- Snooze MODE for reduced-power standby
- JEDEC 100-pin QFP, 165-ball BGA and 119-ball BGA packages
- Power supply:
 - LF: V_{DD} 3.3V ($\pm 5\%$), V_{DDQ} 3.3V/2.5V ($\pm 5\%$)
 - VF: V_{DD} 2.5V ($\pm 5\%$), V_{DDQ} 2.5V ($\pm 5\%$)
- JTAG Boundary Scan for BGA packages
- Industrial and Automotive temperature support
- Lead-free available
- Error Detection and Error Correction

DESCRIPTION

The 4Mb product family features high-speed, low-power synchronous static RAMs designed to provide burstable, high-performance memory for communication and networking applications. The IS61(64)LF/VF12836EC are organized as 131,072 words by 36bits. The IS61(64)LF/VF12832EC are organized as 131,072 words by 32bits. The IS61(64)LF/VF25618EC are organized as 262,144 words by 18 bits. Fabricated with ISSI's advanced CMOS technology, the device integrates a 2-bit burst counter, high-speed SRAM core, and high-drive capability outputs into a single monolithic circuit. All synchronous inputs pass through registers controlled by a positive-edge-triggered single clock input.

Write cycles are internally self-timed and are initiated by the rising edge of the clock input. Write cycles can be one to four bytes wide as controlled by the write control inputs.

Separate byte enables allow individual bytes to be written. The byte write operation is performed by using the byte write enable (/BWE) input combined with one or more individual byte write signals (/BWx). In addition, Global Write (/GW) is available for writing all bytes at one time, regardless of the byte write controls.

Bursts can be initiated with either /ADSP (Address Status Processor) or /ADSC (Address Status Cache Controller) input pins. Subsequent burst addresses can be generated internally and controlled by the /ADV (burst address advance) input pin.

The mode pin is used to select the burst sequence order. Linear burst is achieved when this pin is tied LOW. Interleave burst is achieved when this pin is tied HIGH or left floating.

FAST ACCESS TIME

Symbol	Parameter	-6.5	-7.5	Units
tKQ	Clock Access Time	6.5	7.5	ns
tKC	Cycle time	7.5	8.5	ns
	Frequency	133	117	MHz

Copyright © 2014 Integrated Silicon Solution, Inc. All rights reserved. ISSI reserves the right to make changes to this specification and its products at any time without notice. ISSI assumes no liability arising out of the application or use of any information, products or services described herein. Customers are advised to obtain the latest version of this device specification before relying on any published information and before placing orders for products.

Integrated Silicon Solution, Inc. does not recommend the use of any of its products in life support applications where the failure or malfunction of the product can reasonably be expected to cause failure of the life support system or to significantly affect its safety or effectiveness. Products are not authorized for use in such applications unless Integrated Silicon Solution, Inc. receives written assurance to its satisfaction, that:

- the risk of injury or damage has been minimized;
- the user assume all such risks; and
- potential liability of Integrated Silicon Solution, Inc is adequately protected under the circumstances

BLOCK DIAGRAM

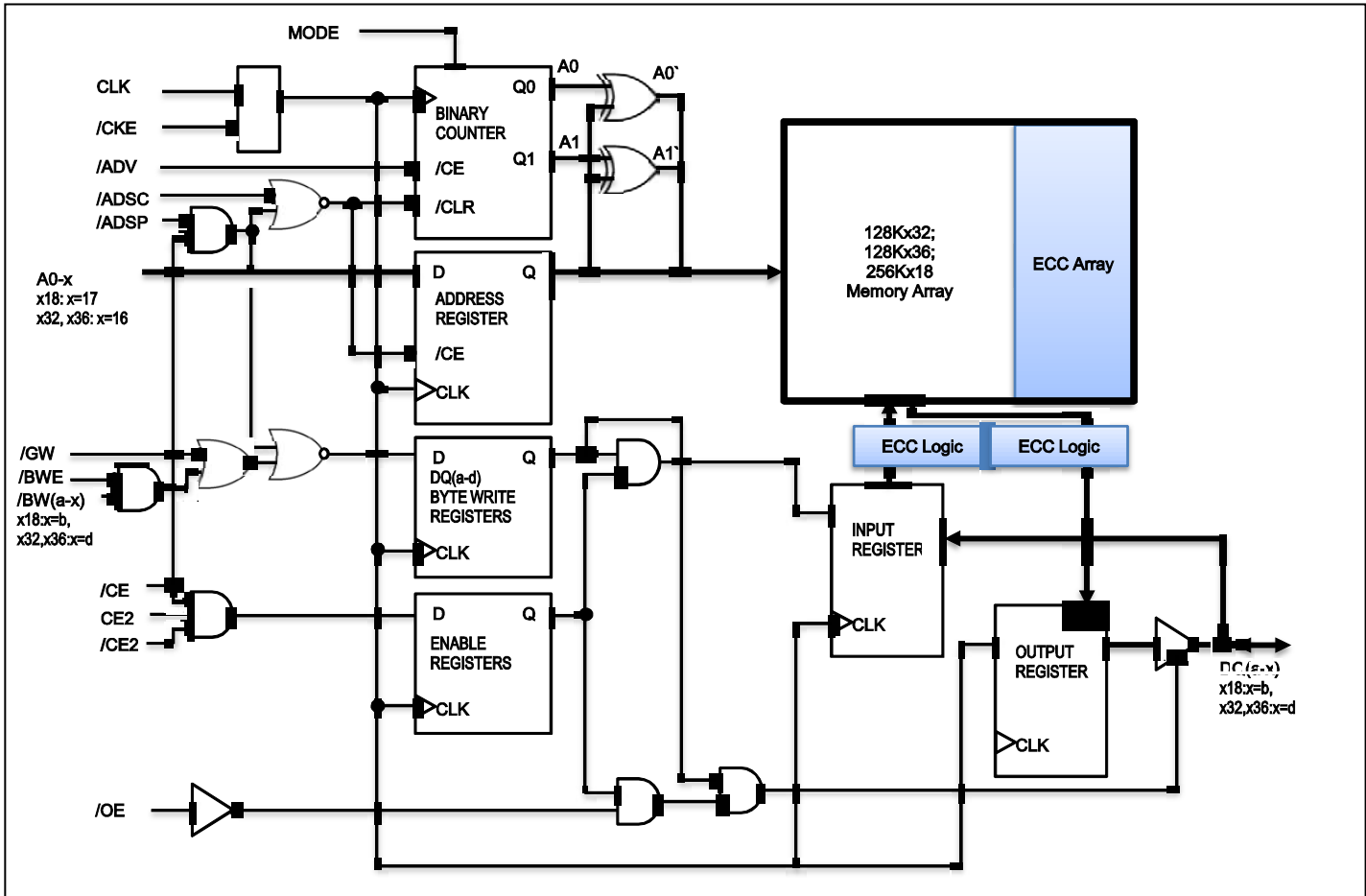

PIN CONFIGURATION

128K x 36, 165-Ball BGA (Top View)

	1	2	3	4	5	6	7	8	9	10	11
A	NC	A	/CE	/BWc	/BWb	/CE2	/BWE	/ADSC	/ADV	A	NC
B	NC	A	CE2	/BWd	/BWa	CLK	/GW	/OE	/ADSP	A	NC
C	DQPc	NC	V _{DDQ}	V _{SS}	V _{SS}	V _{SS}	V _{SS}	V _{SS}	V _{DDQ}	NC	DQPb
D	DQc	DQc	V _{DDQ}	V _{DD}	V _{SS}	V _{SS}	V _{SS}	V _{DD}	V _{DDQ}	DQb	DQb
E	DQc	DQc	V _{DDQ}	V _{DD}	V _{SS}	V _{SS}	V _{SS}	V _{DD}	V _{DDQ}	DQb	DQb
F	DQc	DQc	V _{DDQ}	V _{DD}	V _{SS}	V _{SS}	V _{SS}	V _{DD}	V _{DDQ}	DQb	DQb
G	DQc	DQc	V _{DDQ}	V _{DD}	V _{SS}	V _{SS}	V _{SS}	V _{DD}	V _{DDQ}	DQb	DQb
H	NC	V _{SS}	NC	V _{DD}	V _{SS}	V _{SS}	V _{SS}	V _{DD}	NC	NC	ZZ
J	DQd	DQd	V _{DDQ}	V _{DD}	V _{SS}	V _{SS}	V _{SS}	V _{DD}	V _{DDQ}	DQa	DQa
K	DQd	DQd	V _{DDQ}	V _{DD}	V _{SS}	V _{SS}	V _{SS}	V _{DD}	V _{DDQ}	DQa	DQa
L	DQd	DQd	V _{DDQ}	V _{DD}	V _{SS}	V _{SS}	V _{SS}	V _{DD}	V _{DDQ}	DQa	DQa
M	DQd	DQd	V _{DDQ}	V _{DD}	V _{SS}	V _{SS}	V _{SS}	V _{DD}	V _{DDQ}	DQa	DQa
N	DQPd	NC	V _{DDQ}	V _{SS}	NC	NC	NC	V _{SS}	V _{DDQ}	NC	DQPd
P	NC	NC	A	A	TDI	A1*	TDO	A	A	A	NC
R	MODE	NC	A	A	TMS	A0*	TCK	A	A	A	A

Note: A0 and A1 are the two least significant bits (LSB) of the address field and set the internal burst counter if burst is desired

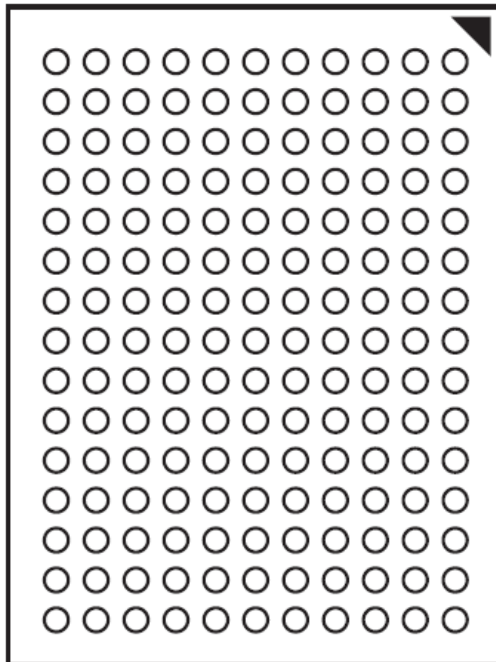

Bottom View
 165-Ball, 13 mm x 15mm BGA
 11 x 15 Ball Array

PIN DESCRIPTIONS

Symbol	Pin Name
CLK	Synchronous Clock
A0,A1	Synchronous Burst Address Inputs
A	Synchronous Address Inputs
/ADV	Synchronous Burst Address Advance
/ADSP	Synchronous Address Status Processor
/ADSC	Synchronous Address Status Controller
MODE	Burst Sequence Selection
/CE,CE2,/CE2	Synchronous Chip Enable
/BWE	Synchronous Byte Write Enable
/BWx (x=a-d)	Synchronous Byte Write Inputs
/GW	Synchronous Global Write Enable
/OE	Asynchronous Output Enable
DQx	Synchronous Data Inputs/Outputs
DQPx	Synchronous Parity Data I/O
TCK,TDI,TDO,TMS	JTAG Pins
ZZ	Asynchronous Power Sleep Mode
NC	No Connect
VDD	Power Supply
VDDQ	I/O Power Supply
VSS	Ground

**IS61(4)LF12836EC/IS61(4)VF12836EC/IS61(4)LF12832EC
IS61(4)VF12832EC/IS61(4)LF25618EC/IS61(4)VF25618EC**



128K x 32, 165-Ball BGA (Top View)

	1	2	3	4	5	6	7	8	9	10	11
A	NC	A	/CE	/BWc	/BWb	/CE2	/BWE	/ADSC	/ADV	A	NC
B	NC	A	CE2	/BWd	/BWa	CLK	/GW	/OE	/ADSP	A	NC
C	NC	NC	V _{DDQ}	V _{SS}	V _{SS}	V _{SS}	V _{SS}	V _{SS}	V _{DDQ}	NC	NC
D	DQc	DQc	V _{DDQ}	V _{DD}	V _{SS}	V _{SS}	V _{SS}	V _{DD}	V _{DDQ}	DQb	DQb
E	DQc	DQc	V _{DDQ}	V _{DD}	V _{SS}	V _{SS}	V _{SS}	V _{DD}	V _{DDQ}	DQb	DQb
F	DQc	DQc	V _{DDQ}	V _{DD}	V _{SS}	V _{SS}	V _{SS}	V _{DD}	V _{DDQ}	DQb	DQb
G	DQc	DQc	V _{DDQ}	V _{DD}	V _{SS}	V _{SS}	V _{SS}	V _{DD}	V _{DDQ}	DQb	DQb
H	NC	V _{SS}	NC	V _{DD}	V _{SS}	V _{SS}	V _{SS}	V _{DD}	NC	NC	ZZ
J	DQd	DQd	V _{DDQ}	V _{DD}	V _{SS}	V _{SS}	V _{SS}	V _{DD}	V _{DDQ}	DQa	DQa
K	DQd	DQd	V _{DDQ}	V _{DD}	V _{SS}	V _{SS}	V _{SS}	V _{DD}	V _{DDQ}	DQa	DQa
L	DQd	DQd	V _{DDQ}	V _{DD}	V _{SS}	V _{SS}	V _{SS}	V _{DD}	V _{DDQ}	DQa	DQa
M	DQd	DQd	V _{DDQ}	V _{DD}	V _{SS}	V _{SS}	V _{SS}	V _{DD}	V _{DDQ}	DQa	DQa
N	NC	NC	V _{DDQ}	V _{SS}	NC	NC	NC	V _{SS}	V _{DDQ}	NC	NC
P	NC	NC	A	A	TDI	A1*	TDO	A	A	A	NC
R	MODE	NC	A	A	TMS	A0*	TCK	A	A	A	A

Note: A0 and A1 are the two least significant bits (LSB) of the address field and set the internal burst counter if burst is desired.

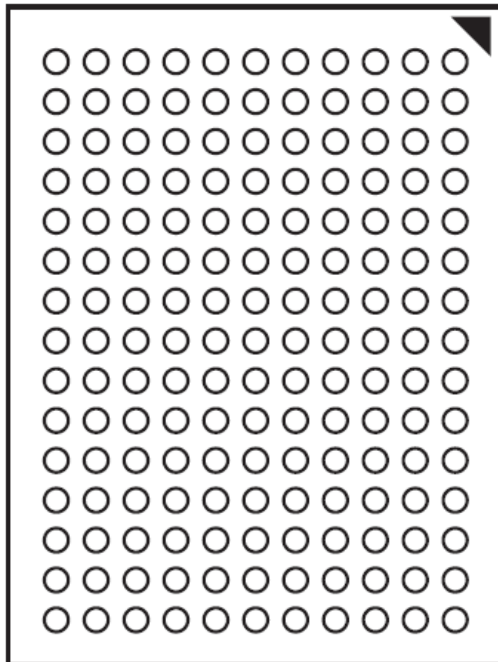

Bottom View
165-Ball, 13 mm x 15mm BGA
11 x 15 Ball Array

PIN DESCRIPTIONS

Symbol	Pin Name
CLK	Synchronous Clock
A0,A1	Synchronous Burst Address Inputs
A	Synchronous Address Inputs
/ADV	Synchronous Burst Address Advance
/ADSP	Synchronous Address Status Processor
/ADSC	Synchronous Address Status Controller
MODE	Burst Sequence Selection
/CE,CE2,/CE2	Synchronous Chip Enable
/BWE	Synchronous Byte Write Enable
/BWx (x=a-d)	Synchronous Byte Write Inputs
/GW	Synchronous Global Write Enable
/OE	Asynchronous Output Enable
DQx	Synchronous Data Inputs/Outputs
TCK,TDI,TDO,TMS	JTAG Pins
ZZ	Asynchronous Power Sleep Mode
NC	No Connect
VDD	Power Supply
VDDQ	I/O Power Supply
VSS	Ground

256K x 18, 165-Ball BGA (Top View)

	1	2	3	4	5	6	7	8	9	10	11
A	NC	A	/CE	/BWb	NC	/CE2	/BWE	/ADSC	/ADV	A	A
B	NC	A	CE2	NC	/BWa	CLK	/GW	/OE	/ADSP	A	NC
C	NC	NC	V _{DDQ}	V _{SS}	V _{SS}	V _{SS}	V _{SS}	V _{SS}	V _{DDQ}	NC	DQP _a
D	NC	DQb	V _{DDQ}	V _{DD}	V _{SS}	V _{SS}	V _{SS}	V _{DD}	V _{DDQ}	NC	DQ _a
E	NC	DQb	V _{DDQ}	V _{DD}	V _{SS}	V _{SS}	V _{SS}	V _{DD}	V _{DDQ}	NC	DQ _a
F	NC	DQb	V _{DDQ}	V _{DD}	V _{SS}	V _{SS}	V _{SS}	V _{DD}	V _{DDQ}	NC	DQ _a
G	NC	DQb	V _{DDQ}	V _{DD}	V _{SS}	V _{SS}	V _{SS}	V _{DD}	V _{DDQ}	NC	DQ _a
H	NC	V _{SS}	NC	V _{DD}	V _{SS}	V _{SS}	V _{SS}	V _{DD}	NC	NC	ZZ
J	DQb	NC	V _{DDQ}	V _{DD}	V _{SS}	V _{SS}	V _{SS}	V _{DD}	V _{DDQ}	DQ _a	NC
K	DQb	NC	V _{DDQ}	V _{DD}	V _{SS}	V _{SS}	V _{SS}	V _{DD}	V _{DDQ}	DQ _a	NC
L	DQb	NC	V _{DDQ}	V _{DD}	V _{SS}	V _{SS}	V _{SS}	V _{DD}	V _{DDQ}	DQ _a	NC
M	DQb	NC	V _{DDQ}	V _{DD}	V _{SS}	V _{SS}	V _{SS}	V _{DD}	V _{DDQ}	DQ _a	NC
N	DQP _b	NC	V _{DDQ}	V _{SS}	NC	NC	NC	V _{SS}	V _{DDQ}	NC	NC
P	NC	NC	A	A	TDI	A1*	TDO	A	A	A	NC
R	MODE	NC	A	A	TMS	A0*	TCK	A	A	A	A

Note: A0 and A1 are the two least significant bits (LSB) of the address field and set the internal burst counter if burst is desired.

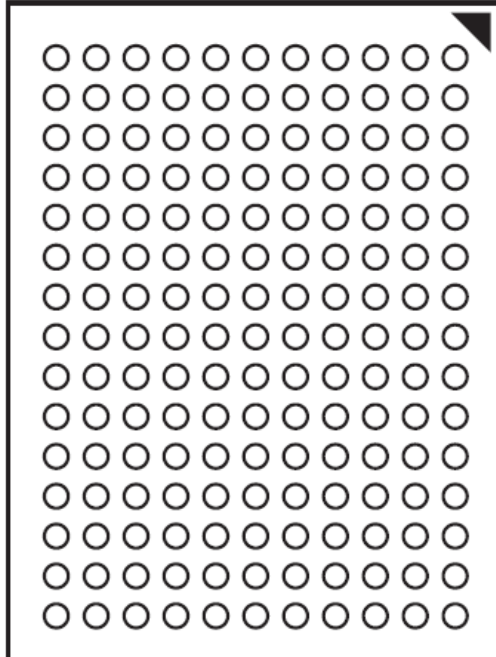

Bottom View
 165-Ball, 13 mm x 15mm BGA
 11 x 15 Ball Array

PIN DESCRIPTIONS

Symbol	Pin Name
CLK	Synchronous Clock
A0,A1	Synchronous Burst Address Inputs
A	Synchronous Address Inputs
/ADV	Synchronous Burst Address Advance
/ADSP	Synchronous Address Status Processor
/ADSC	Synchronous Address Status Controller
MODE	Burst Sequence Selection
/CE,CE2,/CE2	Synchronous Chip Enable
/BWE	Synchronous Byte Write Enable
/BW _x (x=a-b)	Synchronous Byte Write Inputs
/GW	Synchronous Global Write Enable
/OE	Asynchronous Output Enable
DQ _x	Synchronous Data Inputs/Outputs
DQP _x	Synchronous Parity Data I/O
TCK,TDI,TDO,TMS	JTAG Pins
ZZ	Asynchronous Power Sleep Mode
NC	No Connect
VDD	Power Supply
VDDQ	I/O Power Supply
VSS	Ground

**IS61(4)LF12836EC/IS61(4)VF12836EC/IS61(4)LF12832EC
IS61(4)VF12832EC/IS61(4)LF25618EC/IS61(4)VF25618EC**



128K x 36, 119-Ball BGA (Top View)

	1	2	3	4	5	6	7
A	V _{DDQ}	A	A	/ADSP	A	A	V _{DDQ}
B	NC	CE2	A	/ADSC	A	/CE2	NC
C	NC	A	A	V _{DD}	A	A	NC
D	DQc	DQPc	V _{SS}	NC	V _{SS}	DQPb	DQb
E	DQc	DQc	V _{SS}	/CE	V _{SS}	DQb	DQb
F	V _{DDQ}	DQc	V _{SS}	/OE	V _{SS}	DQb	V _{DDQ}
G	DQc	DQc	/BWc	/ADV	/BWb	DQb	DQb
H	DQc	DQc	V _{SS}	/GW	V _{SS}	DQb	DQb
J	V _{DDQ}	V _{DD}	NC	V _{DD}	NC	V _{DD}	V _{DDQ}
K	DQd	DQd	V _{SS}	CLK	V _{SS}	DQa	DQa
L	DQd	DQd	/BWd	NC	/BWa	DQa	DQa
M	V _{DDQ}	DQd	V _{SS}	/BWE	V _{SS}	DQa	V _{DDQ}
N	DQd	DQd	V _{SS}	A1*	V _{SS}	DQa	DQa
P	DQd	DQPd	V _{SS}	A0*	V _{SS}	DQPa	DQa
R	NC	A	MODE	V _{DD}	NC	A	NC
T	NC	NC	A	A	A	NC	ZZ
U	V _{DDQ}	TMS	TDI	TCK	TDO	NC	V _{DDQ}

Note: A0 and A1 are the two least significant bits (LSB) of the address field and set the internal burst counter if burst is desired.

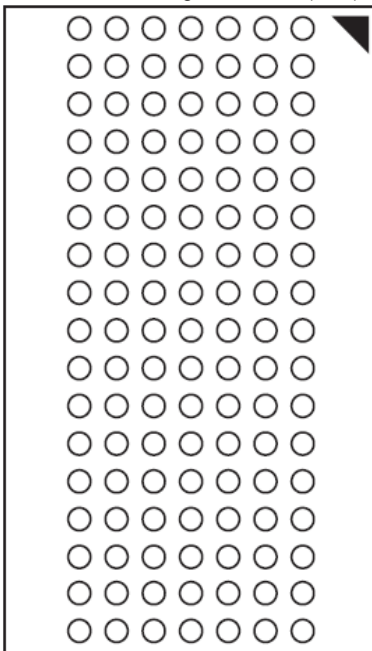

Bottom View
119-Ball, 14 mm x 22 mm BGA
7 x 17 Ball Array

PIN DESCRIPTIONS

Symbol	Pin Name
CLK	Synchronous Clock
A0,A1	Synchronous Burst Address Inputs
A	Synchronous Address Inputs
/ADV	Synchronous Burst Address Advance
/ADSP	Synchronous Address Status Processor
/ADSC	Synchronous Address Status Controller
MODE	Burst Sequence Selection
/CE,CE2,/CE2	Synchronous Chip Enable
/BWE	Synchronous Byte Write Enable
/BWx (x=a-d)	Synchronous Byte Write Inputs
/GW	Synchronous Global Write Enable
/OE	Asynchronous Output Enable
DQx	Synchronous Data Inputs/Outputs
DQPx	Synchronous Parity Data I/O
TCK,TDI,TDO,TMS	JTAG Pins
ZZ	Asynchronous Power Sleep Mode
NC	No Connect
VDD	Power Supply
VDDQ	I/O Power Supply
VSS	Ground

**IS61(4)LF12836EC/IS61(4)VF12836EC/IS61(4)LF12832EC
IS61(4)VF12832EC/IS61(4)LF25618EC/IS61(4)VF25618EC**



128K x 32, 119-Ball BGA (Top View)

	1	2	3	4	5	6	7
A	V _{DDQ}	A	A	/ADSP	A	A	V _{DDQ}
B	NC	CE2	A	/ADSC	A	/CE2	NC
C	NC	A	A	V _{DD}	A	A	NC
D	DQc	NC	V _{SS}	NC	V _{SS}	NC	DQb
E	DQc	DQc	V _{SS}	/CE	V _{SS}	DQb	DQb
F	V _{DDQ}	DQc	V _{SS}	/OE	V _{SS}	DQb	V _{DDQ}
G	DQc	DQc	/BWc	/ADV	/BWb	DQb	DQb
H	DQc	DQc	V _{SS}	/GW	V _{SS}	DQb	DQb
J	V _{DDQ}	V _{DD}	NC	V _{DD}	NC	V _{DD}	V _{DDQ}
K	DQd	DQd	V _{SS}	CLK	V _{SS}	DQa	DQa
L	DQd	DQd	/BWd	NC	/BWA	DQa	DQa
M	V _{DDQ}	DQd	V _{SS}	/BWE	V _{SS}	DQa	V _{DDQ}
N	DQd	DQd	V _{SS}	A1*	V _{SS}	DQa	DQa
P	DQd	NC	V _{SS}	A0*	V _{SS}	NC	DQa
R	NC	A	MODE	V _{DD}	NC	A	NC
T	NC	NC	A	A	A	NC	ZZ
U	V _{DDQ}	TMS	TDI	TCK	TDO	NC	V _{DDQ}

Note: A0 and A1 are the two least significant bits (LSB) of the address field and set the internal burst counter if burst is desired.

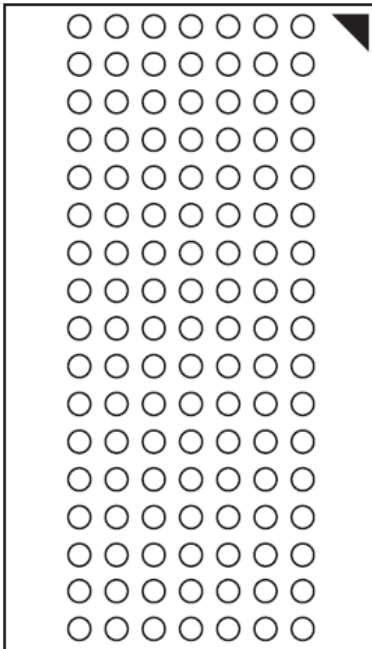

Bottom View
119-Ball, 14 mm x 22 mm BGA
7 x 17 Ball Array

PIN DESCRIPTIONS

Symbol	Pin Name
CLK	Synchronous Clock
A0,A1	Synchronous Burst Address Inputs
A	Synchronous Address Inputs
/ADV	Synchronous Burst Address Advance
/ADSP	Synchronous Address Status Processor
/ADSC	Synchronous Address Status Controller
MODE	Burst Sequence Selection
/CE,CE2,/CE2	Synchronous Chip Enable
/BWE	Synchronous Byte Write Enable
/BWx (x=a-b)	Synchronous Byte Write Inputs
/GW	Synchronous Global Write Enable
/OE	Asynchronous Output Enable
DQx	Synchronous Data Inputs/Outputs
TCK,TDI,TDO,TMS	JTAG Pins
ZZ	Asynchronous Power Sleep Mode
NC	No Connect
VDD	Power Supply
VDDQ	I/O Power Supply
VSS	Ground

256K x 18, 119-Ball BGA (Top View)

	1	2	3	4	5	6	7
A	V _{DDQ}	A	A	/ADSP	A	A	V _{DDQ}
B	NC	CE2	A	/ADSC	A	/CE2	NC
C	NC	A	A	V _{DD}	A	A	NC
D	DQb	NC	V _{SS}	NC	V _{SS}	DQP _a	NC
E	NC	DQb	V _{SS}	/CE	V _{SS}	NC	DQ _a
F	V _{DDQ}	NC	V _{SS}	/OE	V _{SS}	DQ _a	V _{DDQ}
G	NC	DQb	/BW _b	/ADV	V _{SS}	NC	DQ _a
H	DQb	NC	V _{SS}	/GW	V _{SS}	DQ _a	NC
J	V _{DDQ}	V _{DD}	NC	V _{DD}	NC	V _{DD}	V _{DDQ}
K	NC	DQb	V _{SS}	CLK	V _{SS}	NC	DQ _a
L	DQb	NC	V _{SS}	NC	/BW _a	DQ _a	NC
M	V _{DDQ}	DQb	V _{SS}	/BWE	V _{SS}	NC	V _{DDQ}
N	DQb	NC	V _{SS}	A1*	V _{SS}	DQ _a	NC
P	NC	DQP _b	V _{SS}	A0*	V _{SS}	NC	DQ _a
R	NC	A	MODE	V _{DD}	NC	A	NC
T	NC	A	A	NC	A	A	ZZ
U	V _{DDQ}	TMS	TDI	TCK	TDO	NC	V _{DDQ}

Note: A0 and A1 are the two least significant bits (LSB) of the address field and set the internal burst counter if burst is desired.

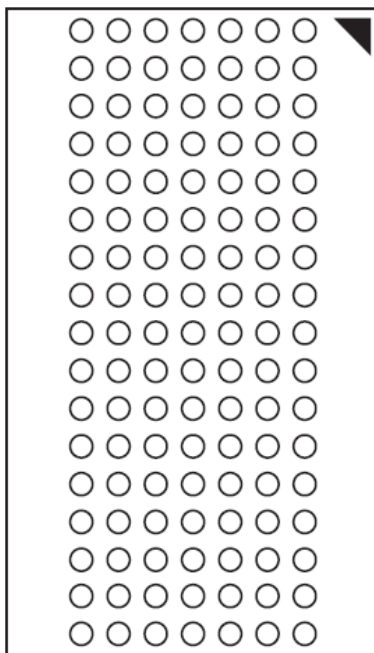

Bottom View
 119-Ball, 14 mm x 22 mm BGA
 7 x 17 Ball Array

PIN DESCRIPTIONS

Symbol	Pin Name
CLK	Synchronous Clock
A0,A1	Synchronous Burst Address Inputs
A	Synchronous Address Inputs
/ADV	Synchronous Burst Address Advance
/ADSP	Synchronous Address Status Processor
/ADSC	Synchronous Address Status Controller
MODE	Burst Sequence Selection
/CE,CE2,/CE2	Synchronous Chip Enable
/BWE	Synchronous Byte Write Enable
/BW _x (x=a-b)	Synchronous Byte Write Inputs
/GW	Synchronous Global Write Enable
/OE	Asynchronous Output Enable
DQ _x	Synchronous Data Inputs/Outputs
DQP _x	Synchronous Parity Data I/O
TCK,TDI,TDO,TMS	JTAG Pins
ZZ	Asynchronous Power Sleep Mode
NC	No Connect
VDD	Power Supply
VDDQ	I/O Power Supply
VSS	Ground

**IS61(4)LF12836EC/IS61(4)VF12836EC/IS61(4)LF12832EC
IS61(4)VF12832EC/IS61(4)LF25618EC/IS61(4)VF25618EC**



128K x 36, 100PIN QFP (Top View)

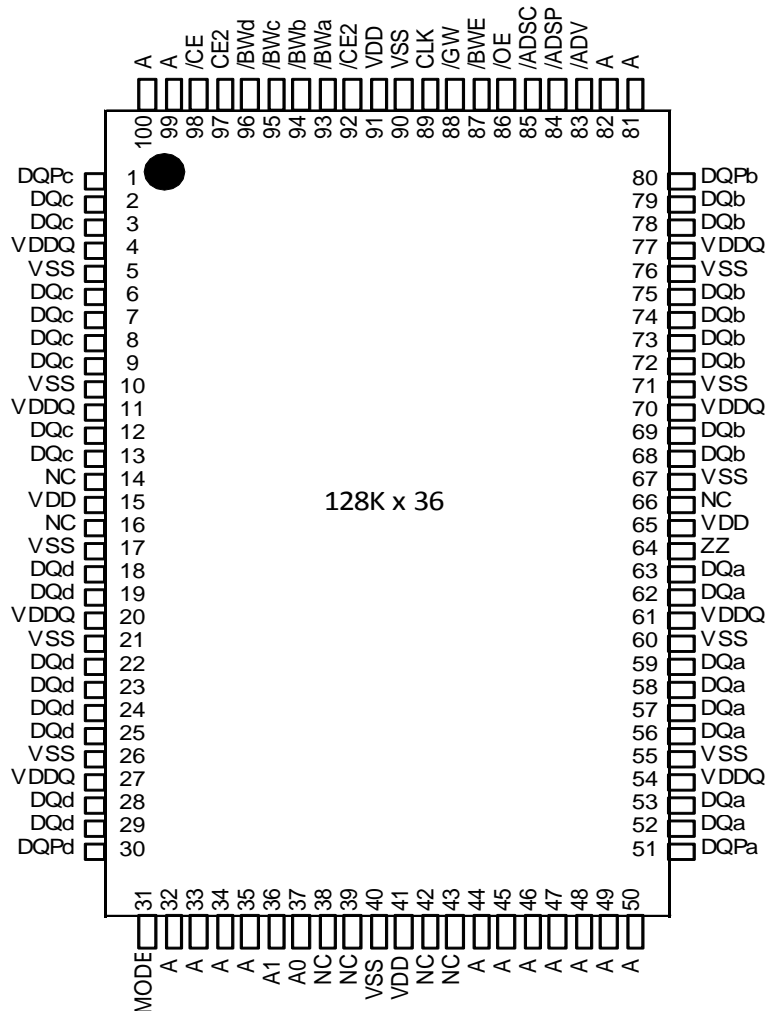

Note: A0 and A1 are the two least significant bits (LSB) of the address field and set the internal burst counter if burst is desired.

PIN DESCRIPTIONS

Symbol	Pin Name	Symbol	Pin Name
CLK	Synchronous Clock	/GW	Synchronous Global Write Enable
A0,A1	Synchronous Burst Address Inputs	/OE	Asynchronous Output Enable
A	Synchronous Address Inputs	DQx	Synchronous Data Inputs/Outputs
/ADV	Synchronous Burst Address Advance	DQP _x	Synchronous Parity Data I/O
/ADSP	Synchronous Address Status Processor	ZZ	Asynchronous Power Sleep Mode
/ADSC	Synchronous Address Status Controller	NC	No Connect
MODE	Burst Sequence Selection	VDD	Power Supply
/CE,CE2,/CE2	Synchronous Chip Enable	VDDQ	I/O Power Supply
/BWE	Synchronous Byte Write Enable	VSS	Ground
/BW _x (x=a-d)	Synchronous Byte Write Inputs		

IS61(4)LF12836EC/IS61(4)VF12836EC/IS61(4)LF12832EC
 IS61(4)VF12832EC/IS61(4)LF25618EC/IS61(4)VF25618EC



128K x 32, 100PIN QFP (Top View)

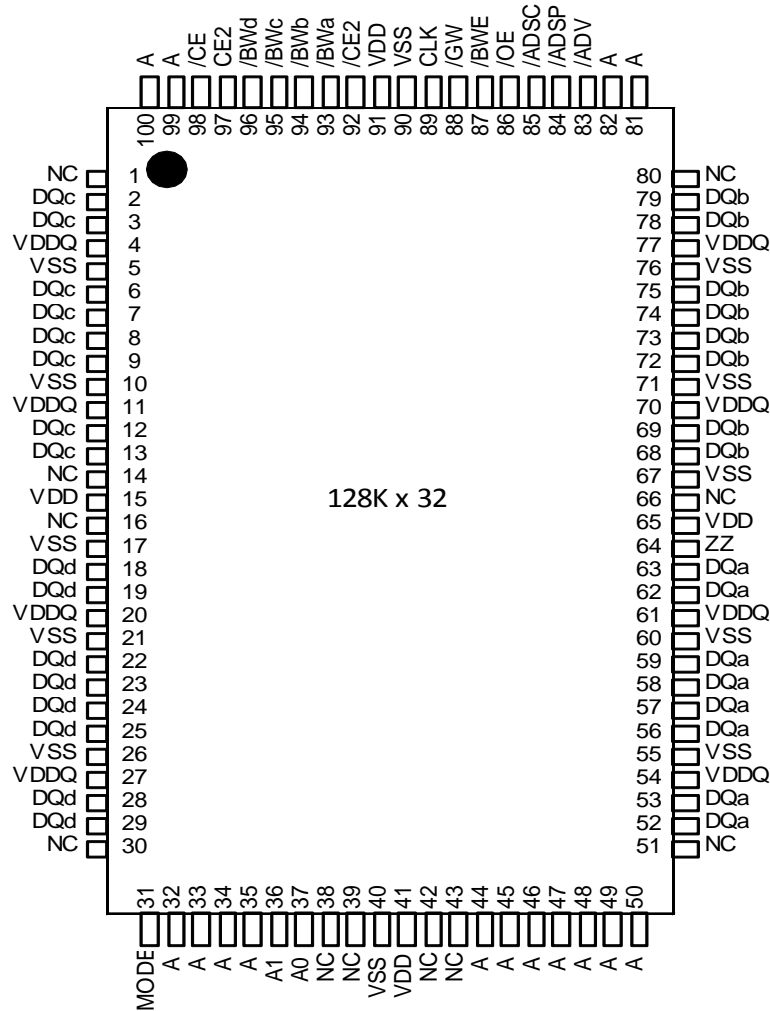

Note: A0 and A1 are the two least significant bits (LSB) of the address field and set the internal burst counter if burst is desired.

PIN DESCRIPTIONS

Symbol	Pin Name	Symbol	Pin Name
CLK	Synchronous Clock	/BWx (x=a-d)	Synchronous Byte Write Inputs
A0,A1	Synchronous Burst Address Inputs	/GW	Synchronous Global Write Enable
A	Synchronous Address Inputs	/OE	Asynchronous Output Enable
/ADV	Synchronous Burst Address Advance	DQx	Synchronous Data Inputs/Outputs
/ADSP	Synchronous Address Status Processor	ZZ	Asynchronous Power Sleep Mode
/ADSC	Synchronous Address Status Controller	NC	No Connect
MODE	Burst Sequence Selection	VDD	Power Supply
/CE,CE2,/CE2	Synchronous Chip Enable	VDDQ	I/O Power Supply
/BWE	Synchronous Byte Write Enable	VSS	Ground

IS61(4)LF12836EC/IS61(4)VF12836EC/IS61(4)LF12832EC
 IS61(4)VF12832EC/IS61(4)LF25618EC/IS61(4)VF25618EC



256K x 18, 100PIN QFP (Top View)

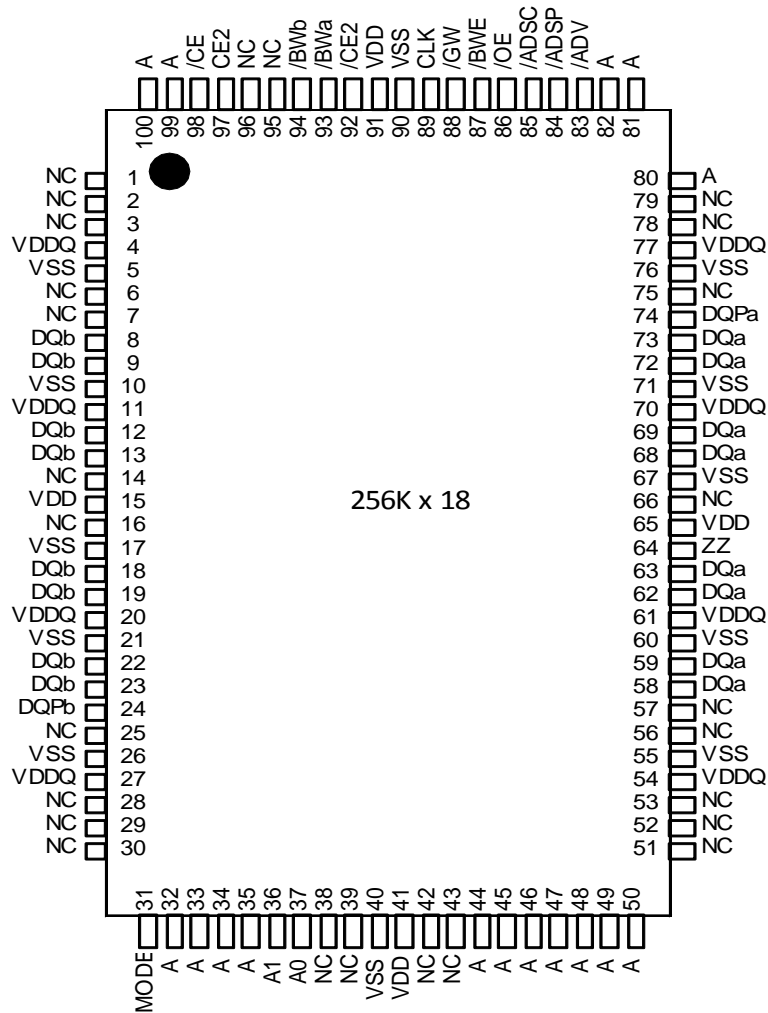

Note: A0 and A1 are the two least significant bits (LSB) of the address field and set the internal burst counter if burst is desired.

PIN DESCRIPTIONS

Symbol	Pin Name	Symbol	Pin Name
CLK	Synchronous Clock	/GW	Synchronous Global Write Enable
A0,A1	Synchronous Burst Address Inputs	/OE	Asynchronous Output Enable
A	Synchronous Address Inputs	DQx	Synchronous Data Inputs/Outputs
/ADV	Synchronous Burst Address Advance	DQPx	Synchronous Parity Data I/O
/ADSP	Synchronous Address Status Processor	ZZ	Asynchronous Power Sleep Mode
/ADSC	Synchronous Address Status Controller	NC	No Connect
MODE	Burst Sequence Selection	VDD	Power Supply
/CE,CE2,/CE2	Synchronous Chip Enable	VDDQ	I/O Power Supply
/BWE	Synchronous Byte Write Enable	VSS	Ground
/BWx (x=a-b)	Synchronous Byte Write Inputs		



TRUTH TABLE

SYNCHRONOUS TRUTH TABLE

OPERATION	ADDRESS	/CE	/CE2	CE2	ZZ	ADSP	ADSC	ADV	WRITE	/OE	CLK	DQ
Deselect Cycle, Power-Down	None	H	X	X	L	X	L	X	X	X	L-H	High-Z
Deselect Cycle, Power-Down	None	L	X	L	L	L	X	X	X	X	L-H	High-Z
Deselect Cycle, Power-Down	None	L	H	X	L	L	X	X	X	X	L-H	High-Z
Deselect Cycle, Power-Down	None	L	X	L	L	H	L	X	X	X	L-H	High-Z
Deselect Cycle, Power-Down	None	L	H	X	L	H	L	X	X	X	L-H	High-Z
Snooze Mode, Power-Down	None	X	X	X	H	X	X	X	X	X	X	High-Z
Read Cycle, Begin Burst	External	L	L	H	L	L	X	X	X	L	L-H	Q
Read Cycle, Begin Burst	External	L	L	H	L	L	X	X	X	H	L-H	High-Z
Write Cycle, Begin Burst	External	L	L	H	L	H	L	X	L	X	L-H	D
Read Cycle, Begin Burst	External	L	L	H	L	H	L	X	H	L	L-H	Q
Read Cycle, Begin Burst	External	L	L	H	L	H	L	X	H	H	L-H	High-Z
Read Cycle, Continue Burst	Next	X	X	X	L	H	H	L	H	L	L-H	Q
Read Cycle, Continue Burst	Next	X	X	X	L	H	H	L	H	H	L-H	High-Z
Read Cycle, Continue Burst	Next	H	X	X	L	X	H	L	H	L	L-H	Q
Read Cycle, Continue Burst	Next	H	X	X	L	X	H	L	H	H	L-H	High-Z
Write Cycle, Continue Burst	Next	X	X	X	L	H	H	L	L	X	L-H	D
Write Cycle, Continue Burst	Next	H	X	X	L	X	H	L	L	X	L-H	D
Read Cycle, Suspend Burst	Current	X	X	X	L	H	H	H	H	L	L-H	Q
Read Cycle, Suspend Burst	Current	X	X	X	L	H	H	H	H	H	L-H	High-Z
Read Cycle, Suspend Burst	Current	H	X	X	L	X	H	H	H	L	L-H	Q
Read Cycle, Suspend Burst	Current	H	X	X	L	X	H	H	H	H	L-H	High-Z
Write Cycle, Suspend Burst	Current	X	X	X	L	H	H	H	L	X	L-H	D
Write Cycle, Suspend Burst	Current	H	X	X	L	X	H	H	L	X	L-H	D

NOTE:

1. X means "Don't Care." H means logic HIGH. L means logic LOW.
2. For WRITE, L means one or more byte write enable signals (/BWA-d) and /BWE are LOW or /GW is LOW. /WRITE = H for all /BWx, /BWE, /GW HIGH.
3. /BWA enables WRITES to DQa's and DQPd. /BWb enables WRITES to DQb's and DQPb. /BWc enables WRITES to DQc's and DQPc. /BWD enables WRITES to DQd's and DQPd. DQPd and DQPb are available on the x18 version. DQPd-DQPc are available on the x36 version.
4. All inputs except /OE and ZZ must meet setup and hold times around the rising edge (LOW to HIGH) of CLK.
5. Wait states are inserted by suspending burst.
6. For a WRITE operation following a READ operation, /OE must be HIGH before the input data setup time and held HIGH during the input data hold time.
7. This device contains circuitry that will ensure the outputs will be in High-Z during power-up.
8. /ADSP LOW always initiates an internal READ at the L-H edge of CLK. A WRITE is performed by setting one or more byte write enable signals and /BWE LOW or /GW LOW for the subsequent L-H edge of CLK. See WRITE timing diagram for clarification.

PARTIAL TRUTH TABLE

Operation	/GW	/BWE	/BWa	/BWb	/BWc	/BWd
READ	H	H	X	X	X	X
READ	H	L	H	H	H	H
WRITE BYTE a	H	L	L	H	H	H
WRITE BYTE b	H	L	H	L	H	H
WRITE BYTE c	H	L	H	H	L	H
WRITE BYTE d	H	L	H	H	H	L
WRITE ALL BYTES	H	L	L	L	L	L
WRITE ALL BYTES	L	X	X	X	X	X

Notes:

1. X means "Don't Care".
2. All inputs in this table must be setup and hold time around the rising edge of CLK.

ADDRESS SEQUENCE IN BURST MODE

INTERLEAVED BURST ADDRESS TABLE (MODE = V_{dd} or NC)

External Address	1st Burst Address	2nd Burst Address	3rd Burst Address
A1 A0	A1 A0	A1 A0	A1 A0
00	01	10	11
01	00	11	10
10	11	00	01
11	10	01	00

LINEAR BURST ADDRESS TABLE (MODE = V_{ss})

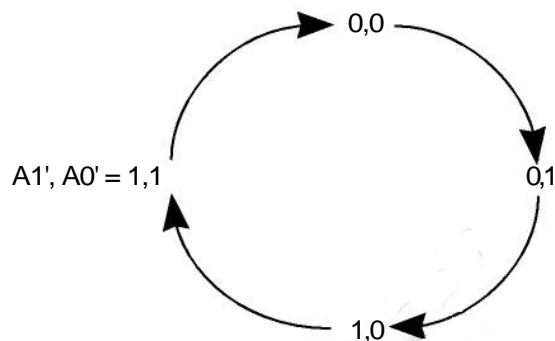

Power Up Sequence

V_{ddq} , V_{dd}¹ , I/O Pins²

Notes:

1. V_{dd} can be applied at the same time as V_{ddq}
2. Applying I/O inputs is recommended after V_{ddq} is stable. The inputs of the I/O pins can be applied at the same time as V_{ddq} as long as V_{ih} (level of I/O pins) is lower than V_{ddq}.



ERROR DETECTION AND CORRECTION

- Independent ECC with Hamming code for each byte.
- Detect and correct one bit error per byte.
- Better reliability than parity code schemes that could detect error bit but NOT correct it.
- Backward compatible : Drop in replacement to current in industry standard devices without ECC.

ABSOLUTE MAXIMUM RATINGS AND OPERATING RANGE

ABSOLUTE MAXIMUM RATINGS

Symbol	Parameter	LF Value	VF Value	Unit
Tstg	Storage Temperature	-65 to +150	-65 to +150	°C
Pd	Power Dissipation	1.6	1.6	W
Iout	Output Current (per I/O)	100	100	mA
Vin, Vout	Voltage Relative to Vss for I/O Pins	-0.5 to Vddq+0.3	-0.5 to Vddq + 0.3	V
Vin	Voltage Relative to Vss for Address and Control Inputs	-0.3 to Vdd+0.5	-0.3 to Vdd + 0.3	V

Notes:

1. Stress greater than those listed under ABSOLUTE MAXIMUM RATINGS may cause permanent damage to the device. This is a stress rating only and functional operation of the device at these or any other conditions above those indicated in the operational sections of this specification is not implied. Exposure to absolute maximum rating conditions for extended periods may affect reliability.
2. This device contains circuitry to protect the inputs against damage due to high static voltages or electric fields; however, precautions may be taken to avoid application of any voltage higher than maximum rated voltages to this high-impedance circuit.
3. This device contains circuitry that will ensure the output devices are in High-Z at power up.

OPERATING RANGE

Option	Range	VDD	VDDQ	Ambient Temperature
IS61LFXXXXX	Commercial	3.3V ± 5%	3.3V / 2.5V ± 5%	0°C to +70°C
	Industrial	3.3V ± 5%	3.3V / 2.5V ± 5%	-40°C to +85°C
IS61VFXXXXX	Commercial	2.5V ± 5%	2.5V ± 5%	0°C to +70°C
	Industrial	2.5V ± 5%	2.5V ± 5%	-40°C to +85°C
IS64LFXXXXX	Automotive	3.3V ± 5%	3.3V / 2.5V ± 5%	-40°C to +125°C
IS64VFXXXXX	Automotive	2.5V ± 5%	2.5V ± 5%	-40°C to +125°C

**IS61(4)LF12836EC/IS61(4)VF12836EC/IS61(4)LF12832EC
IS61(4)VF12832EC/IS61(4)LF25618EC/IS61(4)VF25618EC**



CHARACTERISTICS

DC ELECTRICAL CHARACTERISTICS (Over operating temperature range)

Symbol	Parameter	Test Conditions	3.3V		2.5V		Unit
			Min.	Max.	Min.	Max.	
Voh	Output HIGH Voltage	loh=-4.0 mA(3.3V) loh=-1.0 mA(2.5V)	2.4	—	2.0	—	V
Vol	Output LOW Voltage	lol=8.0 mA(3.3V) lol=1.0 mA(2.5V)	—	0.4	—	0.4	V
Vih	Input HIGH Voltage		2.0	Vdd+0.3	1.7	Vdd+0.3	V
Vil	Input LOW Voltage		-0.3	0.8	-0.3	0.7	V
Ili	Input Leakage Current	VssdVindVdd	-5	5	-5	5	μA
Ilo	Output Leakage Current	VssdVoutdVddq,/OE=Vih	-5	5	-5	5	μA

Notes:

- All voltages referenced to ground.
- Overshoot:
3.3V and 2.5V: Vih (AC) d Vdd + 1.5V (Pulse width less than tkc /2)
1.8V: Vih (AC) d Vdd + 0.5V (Pulse width less than tkc /2)
- Undershoot:
3.3V and 2.5V: Vil (AC) e -1.5V (Pulse width less than tkc /2)
1.8V: Vil (AC) e -0.5V (Pulse width less than tkc /2)

POWER SUPPLY CHARACTERISTICS (Over Operating Range)

Symbol	Parameter	Test Conditions	Temp. range	-6.5		-7.5		Unit
				MAX		MAX		
				x18	x36/32	x18	x36/32	
Icc	AC Operating, Supply Current	Device Selected, OE = Vih, ZZ d Vil, All Inputs d 0.2V or e Vdd - 0.2V, Cycle Time e tkc min.	Com.	175	175	155	155	mA
			Ind.	180	180	160	160	
			Auto	190	190	175	175	
Isb	Standby Current TTL Input	Device Deselected, Vdd = Max., All Inputs d Vil or e Vih, ZZ d Vil, f = Max.	Com.	100	100	100	100	mA
			Ind.	110	110	110	110	
			Auto	130	130	130	130	
Isb1	Standby Current CMOS Input	Device Deselected, Vdd = Max., Vin d Vss + 0.2V or e Vdd - 0.2V, f = 0	Com.	80	80	80	80	mA
			Ind.	85	85	85	85	
			Auto	100	100	100	100	

Note:

- MODE pin has an internal pullup and should be tied to Vdd or Vss . It exhibits ±100% maximum leakage current when tied to dVss+0.2V or eVdd-0.2V.

CAPACITANCE

Symbol	Parameter	Conditions	Max.	Unit
Cin	Input Capacitance	Vin = 0V	6	pF
Cout	Input/Output Capacitance	Vout = 0V	8	pF

Notes:

- Tested initially and after any design or process changes that may affect these parameters.
- Test conditions: Ta = 25°C, f = 1 MHz, Vdd = 3.3V.

**IS61(4)LF12836EC/IS61(4)VF12836EC/IS61(4)LF12832EC
IS61(4)VF12832EC/IS61(4)LF25618EC/IS61(4)VF25618EC**



READ/WRITE CYCLE SWITCHING CHARACTERISTICS (Over Operating Range)

Symbol	Parameter	-6.5		-7.5		Unit
		Min.	Max.	Min.	Max.	
fmax	Clock Frequency	—	133	—	117	MHz
tkc	Cycle Time	7.5	—	8.5	—	ns
tkh	Clock High Time	2.2	—	2.5	—	ns
tkl	Clock Low Time	2.2	—	2.5	—	ns
tkq	Clock Access Time	—	6.5	—	7.5	ns
tkqx(2)	Clock High to Output Invalid	2.5	—	2.5	—	ns
tkqlz(2,3)	Clock High to Output Low-Z	2.5	—	2.5	—	ns
tkqhz(2,3)	Clock High to Output High-Z	—	3.8	—	4.0	ns
toeq	Output Enable to Output Valid	—	3.2	—	3.4	ns
toelz(2,3)	Output Enable to Output Low-Z	0	—	0	—	ns
toehz(2,3)	Output Disable to Output High-Z	—	3.5	—	3.5	ns
tas	Address Setup Time	1.5	—	1.5	—	ns
tws	Read/Write Setup Time	1.5	—	1.5	—	ns
tces	Chip Enable Setup Time	1.5	—	1.5	—	ns
tse	Clock Enable Setup Time	1.5	—	1.5	—	ns
tadv	Address Advance Setup Time	1.5	—	1.5	—	ns
tds	Data Setup Time	1.5	—	1.5	—	ns
tah	Address Hold Time	0.5	—	0.5	—	ns
the	Clock Enable Hold Time	0.5	—	0.5	—	ns
twh	Write Hold Time	0.5	—	0.5	—	ns
tceh	Chip Enable Hold Time	0.5	—	0.5	—	ns
tadvh	Address Advance Hold Time	0.5	—	0.5	—	ns
tdh	Data Hold Time	0.5	—	0.5	—	ns
tpower(4)	Vdd (typical) to First Access	1	—	1	—	ms

- Notes:
1. Configuration signal MODE is static and must not change during normal operation.
 2. Guaranteed but not 100% tested. This parameter is periodically sampled.
 3. Tested with load in Figure 2.
 4. tpower is the time that the power needs to be supplied above Vdd (min) initially before READ or WRITE operation can be initiated.

3.3V I/O AC TEST CONDITIONS

Parameter	Unit
Input Pulse Level	0V to 3.0V
Input Rise and Fall Times	1.5 ns
Input and Output Timing and Reference Level	1.5V
V_{TT}	1.5V
V_{LOAD}	3.3V
R1, R2	317 Ω , 351 Ω
Output Load	See Figures 1 and 2

2.5V I/O AC TEST CONDITIONS

Parameter	Unit
Input Pulse Level	0V to 2.5V
Input Rise and Fall Times	1.5 ns
Input and Output Timing and Reference Level	1.25V
V_{TT}	1.25V
V_{LOAD}	2.5V
R1, R2	1667 Ω , 1538 Ω
Output Load	See Figures 1 and 2

I/O OUTPUT LOAD EQUIVALENT

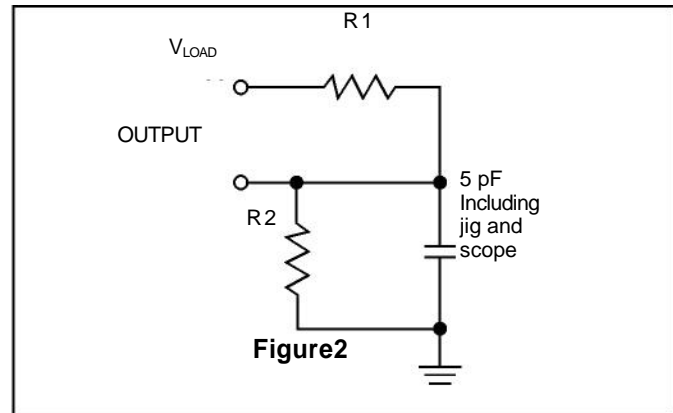
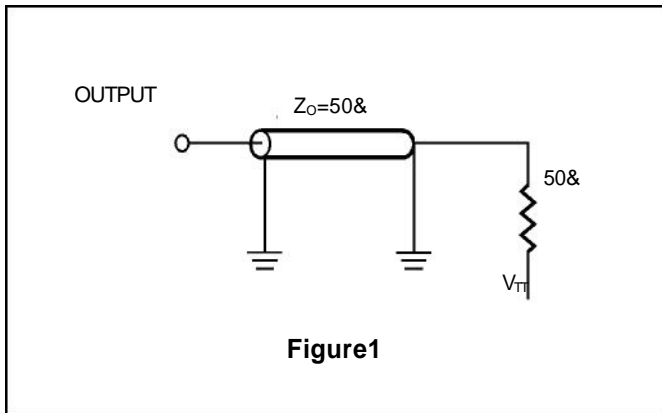

READ/WRITE CYCLE TIMING

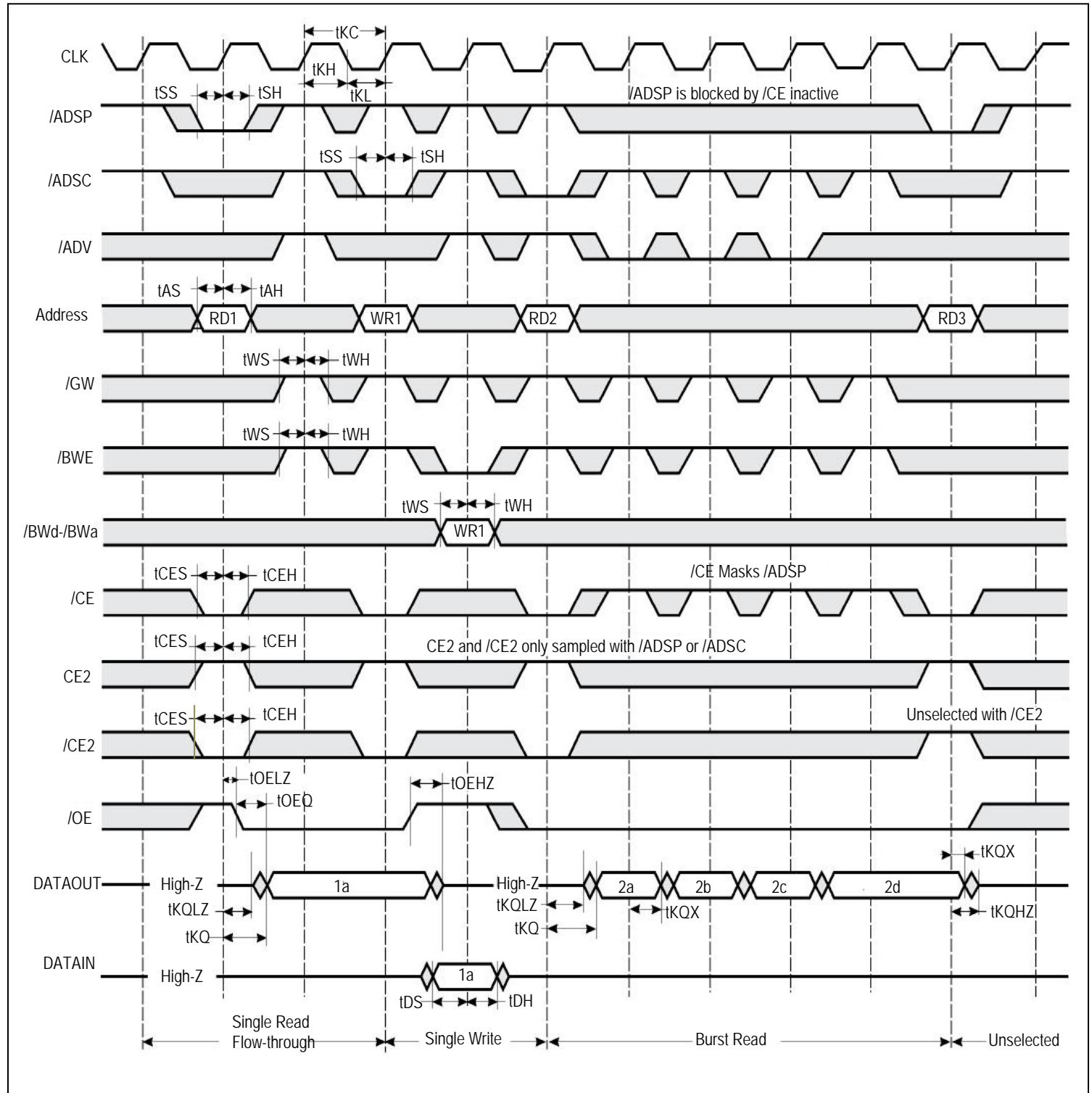

IS61(4)LF12836EC/IS61(4)VF12836EC/IS61(4)LF12832EC IS61(4)VF12832EC/IS61(4)LF25618EC/IS61(4)VF25618EC



WRITE CYCLE TIMING

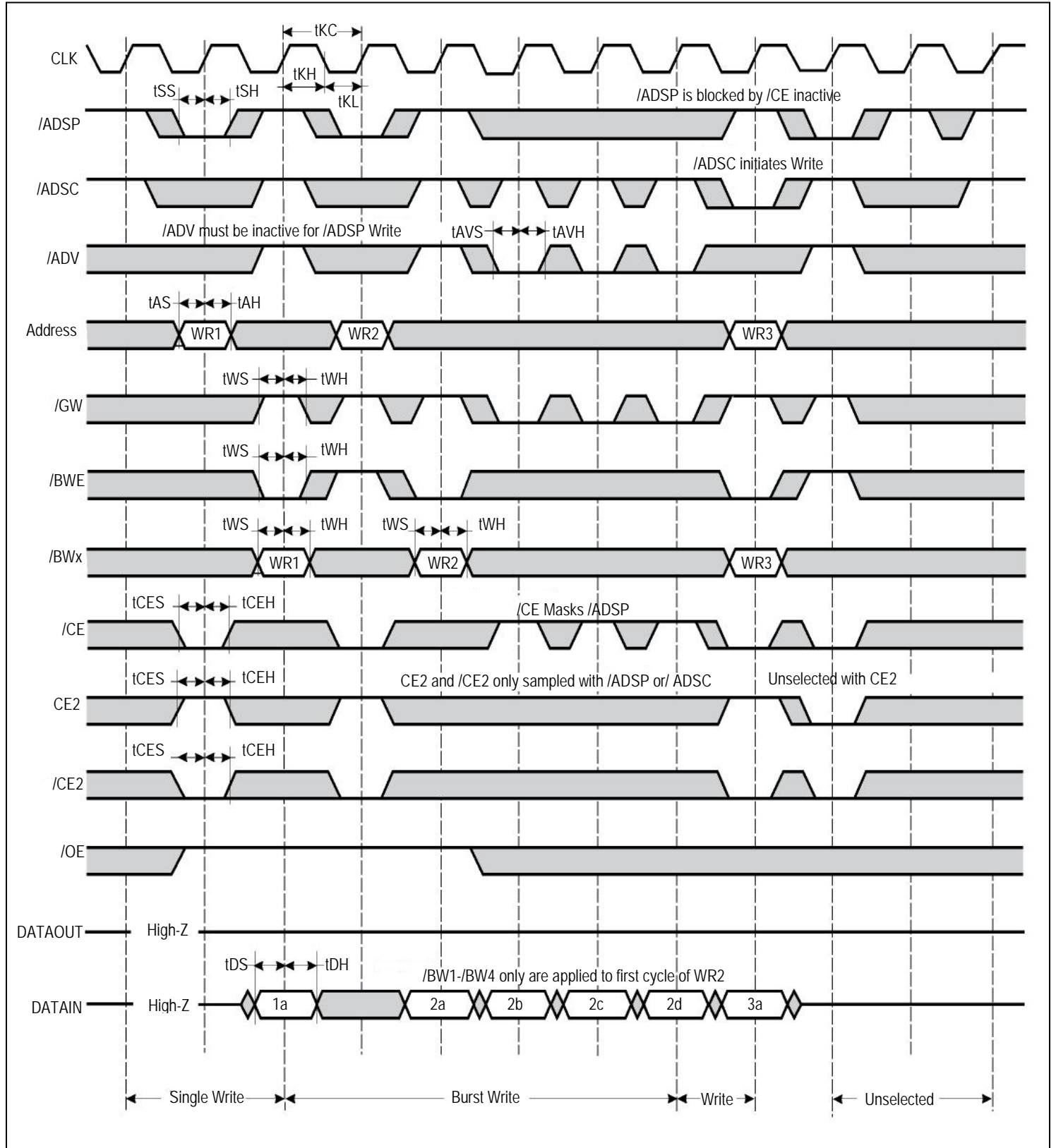

**IS61(4)LF12836EC/IS61(4)VF12836EC/IS61(4)LF12832EC
IS61(4)VF12832EC/IS61(4)LF25618EC/IS61(4)VF25618EC**



SNOOZE MODE ELECTRICAL CHARACTERISTICS

Symbol	Parameter	Conditions	Temperature Range	Min.	Max.	Unit
Isb2	Current during SNOOZE MODE	ZZ e Vih	Com.	—	35	mA
			Ind.	—	40	
			Auto.	—	60	
tpds	ZZ active to input ignored		—	—	2	cycle
tpus	ZZ inactive to input sampled		—	2	—	cycle
tzzi	ZZ active to SNOOZE current		—	—	2	cycle
trzzi	ZZ inactive to exit SNOOZE current		—	0	—	ns

SLEEP MODE TIMING

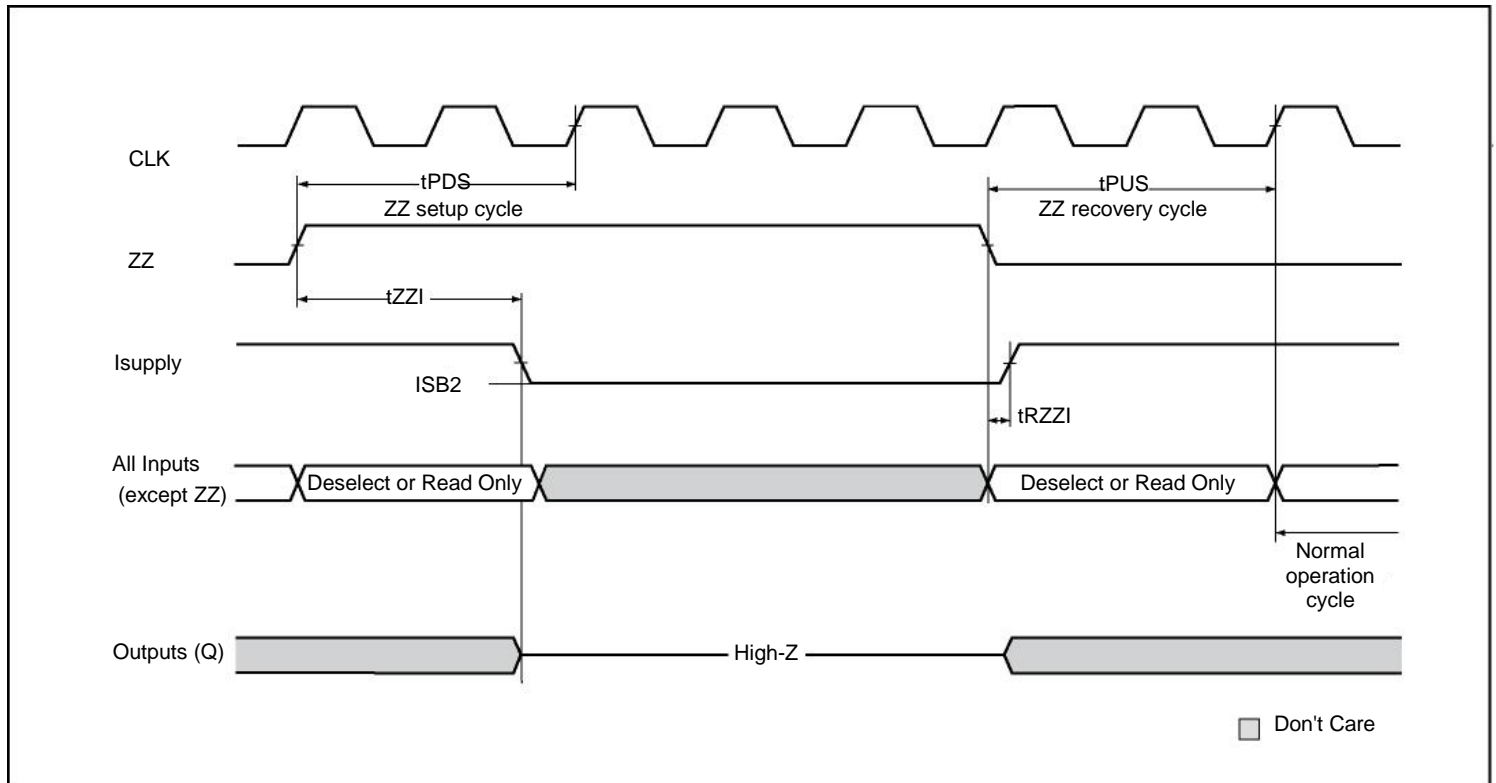

IEEE 1149.1 TAP and Boundary Scan

The SRAM provides a limited set of JTAG functions to test the interconnection between SRAM I/Os and printed circuit board traces or other components. There is no multiplexer in the path from I/O pins to the RAM core.

In conformance with IEEE Standard 1149.1, the SRAM contains a TAP controller, instruction register, boundary scan register, bypass register, and ID register.

The TAP controller has a standard 16-state machine that resets internally on power-up. Therefore, a TRST signal is not required

Disabling the JTAG feature

The SRAM can operate without using the JTAG feature. To disable the TAP controller, TCK must be tied LOW (VSS) to prevent clocking of the device. TDI and TMS are internally pulled up and may be left disconnected. They may alternately be connected to VDD through a pull-up resistor. TDO should be left disconnected. On power-up, the device will come up in a reset state, which will not interfere with device operation.

Test Access Port Signal List:

1. Test Clock (TCK)

This signal uses VDD as a power supply. The test clock is used only with the TAP controller. All inputs are captured on the rising edge of TCK. All outputs are driven from the falling edge of TCK.

2. Test Mode Select (TMS)

This signal uses VDD as a power supply. The TMS input is used to send commands to the TAP controller and is sampled on the rising edge of TCK.

3. Test Data-In (TDI)

This signal uses VDD as a power supply. The TDI input is used to serially input test instructions and information into the registers and can be connected to the input of any of the registers. The register between TDI and TDO is chosen by the instruction that is loaded into the TAP instruction register. TDI is connected to the most significant bit (MSB) of any register. For more information regarding instruction register loading, please see the TAP Controller State Diagram.

4. Test Data-Out (TDO)

This signal uses VDDQ as a power supply. The TDO output ball is used to serially clock test instructions and data out from the registers. The TDO output driver is only active during the Shift-IR and Shift-DR TAP controller states. In all other states, the TDO pin is in a High-Z state. The output changes on the falling edge of TCK. TDO is connected to the least significant bit (LSB) of any register. For more information, please see the TAP Controller State Diagram.

TAP Controller State and Block Diagram

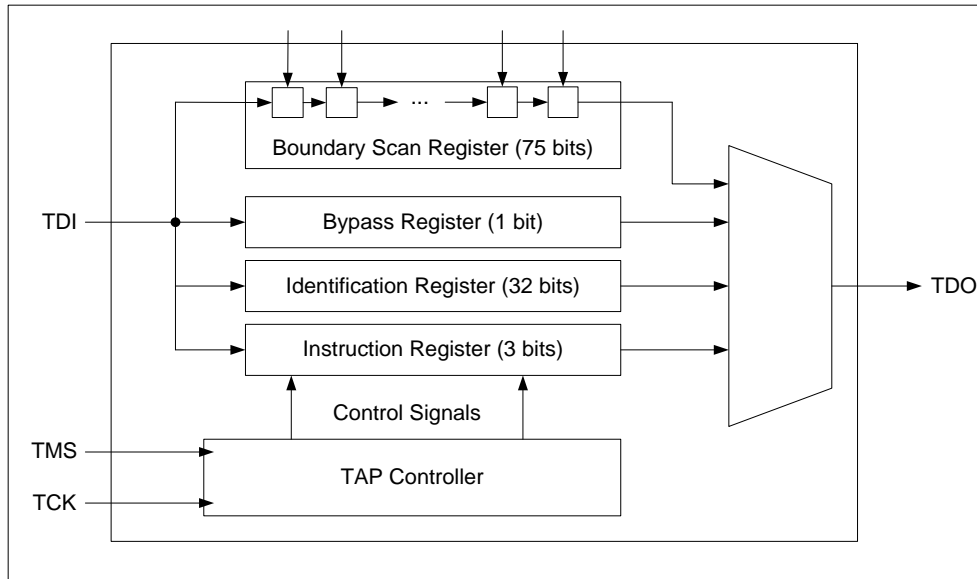

TAP Controller State Machine

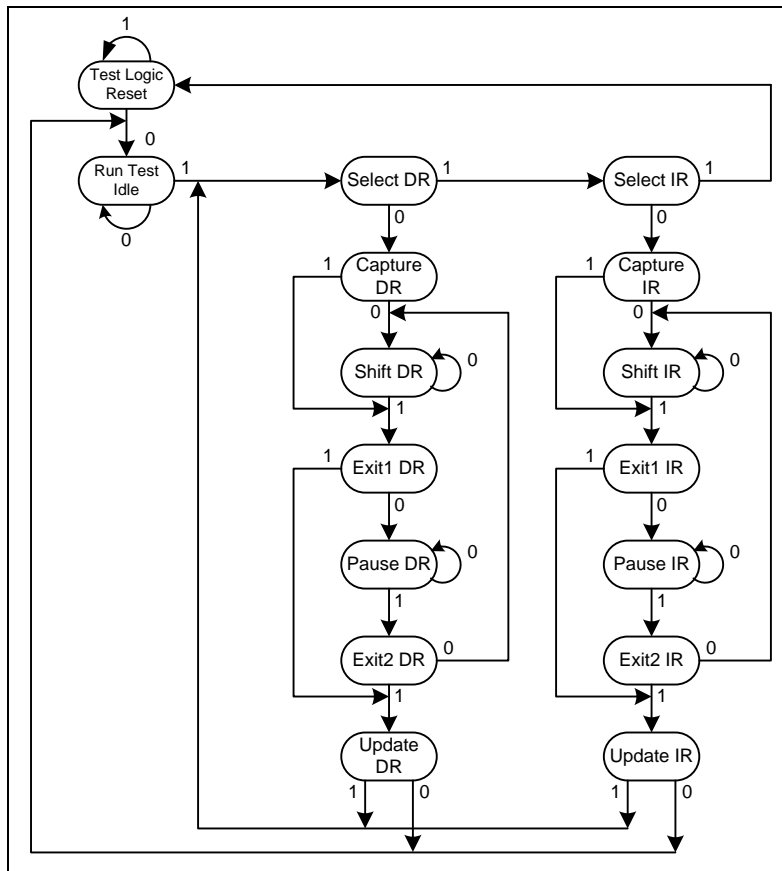



Performing a TAP Reset

A Reset is performed by forcing TMS HIGH (VDD) for five rising edges of TCK. RESET may be performed while the SRAM is operating and does not affect its operation. At power-up, the TAP is internally reset to ensure that TDO comes up in a high-Z state.

TAP Registers

Registers are connected between the TDI and TDO pins and allow data to be scanned into and out of the SRAM test circuitry. Only one register can be selected at a time through the instruction registers. Data is serially loaded into the TDI pin on the rising edge of TCK and output on the TDO pin on the falling edge of TCK.

1. Instruction Register

This register is loaded during the update-IR state of the TAP controller. At power-up, the instruction register is loaded with the IDCODE instruction. It is also loaded with the IDCODE instruction if the controller is placed in a reset state as described in the previous section. When the TAP controller is in the capture-IR state, the two LSBs are loaded with a binary "01" pattern to allow for fault isolation of the board-level serial test data path.

2. Bypass Register

The bypass register is a single-bit register that can be placed between the TDI and TDO balls. This allows data to be shifted through the SRAM with minimal delay. The bypass register is set LOW (V_{SS}) when the BYPASS instruction is executed.

3. Boundary Scan Register

The boundary scan register is connected to all the input and bidirectional balls on the SRAM. Several balls are also included in the scan register to reserved balls. The boundary scan register is loaded with the contents of the SRAM Input and Output ring when the TAP controller is in the capture-DR state and is then placed between the TDI and TDO balls when the controller is moved to the shift-DR state. Each bit corresponds to one of the balls on the SRAM package. The MSB of the register is connected to TDI, and the LSB is connected to TDO.

4. Identification (ID) Register

The ID register is loaded with a vendor-specific, 32-bit code during the capture-DR state when the IDCODE command is loaded in the instruction register. The IDCODE is hardwired into the SRAM and can be shifted out when the TAP controller is in the shift-DR state.

Scan Register Sizes

Register Name	Bit Size
Instruction	3
Bypass	1
ID	32
Boundary Scan	75

TAP Instruction Set

Many instructions are possible with an eight-bit instruction register and all valid combinations are listed in the TAP Instruction Code Table. All other instruction codes that are not listed on this table are reserved and should not be used. Instructions are loaded into the TAP controller during the Shift-IR state when the instruction register is placed between TDI and TDO. During this state, instructions are shifted from the instruction register through the

TDI and TDO pins. To execute an instruction once it is shifted in, the TAP controller must be moved into the Update-IR state.

1. EXTEST

The EXTEST instruction allows circuitry external to the component package to be tested. Boundary-scan register cells at output balls are used to apply a test vector, while those at input balls capture test results. Typically, the first test vector to be applied using the EXTEST instruction will be shifted into the boundary scan register using the PRELOAD instruction. Thus, during the update-IR state of EXTEST, the output driver is turned on, and the PRELOAD data is driven onto the output balls.

2. IDCODE

The IDCODE instruction causes a vendor-specific, 32-bit code to be loaded into the instruction register. It also places the instruction register between the TDI and TDO balls and allows the IDCODE to be shifted out of the device when the TAP controller enters the shift-DR state. The IDCODE instruction is loaded into the instruction register upon power-up or whenever the TAP controller is given a test logic reset state.

3. SAMPLE Z

If the SAMPLE-Z instruction is loaded in the instruction register, all SRAM outputs are forced to an inactive drive state (high-Z), moving the TAP controller into the capture-DR state loads the data in the SRAMs input into the boundary scan register, and the boundary scan register is connected between TDI and TDO when the TAP controller is moved to the shift-DR state.

4. SAMPLE/PRELOAD

When the SAMPLE/PRELOAD instruction is loaded into the instruction register and the TAP controller is in the capture-DR state, a snapshot of data on the inputs and bidirectional balls is captured in the boundary scan register. The user must be aware that the TAP controller clock can only operate at a frequency up to 50 MHz, while the SRAM clock operates significantly faster. Because there is a large difference between the clock frequencies, it is possible that during the capture-DR state, an input or output will undergo a transition. The TAP may then try to capture a signal while in transition. This will not harm the device, but there is no guarantee as to the value that will be captured. Repeatable results may not be possible. To ensure that the boundary scan register will capture the correct value of a signal, the SRAM signal must be stabilized long enough to meet the TAP controller's capture setup plus hold time. The SRAM clock input might not be captured correctly if there is no way in a design to stop (or slow) the clock during a SAMPLE/ PRELOAD instruction. If this is an issue, it is still possible to capture all other signals and simply ignore the value of the CK and CK# captured in the boundary scan register. Once the data is captured, it is possible to shift out the data by putting the TAP into the shift-DR state. This places the boundary scan register between the TDI and TDO balls.

6. BYPASS

When the BYPASS instruction is loaded in the instruction register and the TAP is placed in a shift-DR state, the bypass register is placed between TDI and TDO. The advantage of the BYPASS instruction is that it shortens the boundary scan path when multiple devices are connected together on a board.

7. PRIVATE

Do not use these instructions. They are reserved for future use and engineering mode.

**IS61(4)LF12836EC/IS61(4)VF12836EC/IS61(4)LF12832EC
IS61(4)VF12832EC/IS61(4)LF25618EC/IS61(4)VF25618EC**



JTAG TAP DC ELECTRICAL CHARACTERISTICS (V_{DDQ}=3.3V Operating Range)

Parameter	Symbol	Min	Max	Units	Notes
JTAG Input High Voltage	V _{IH1}	2.0	V _{DD} +0.3	V	
JTAG Input Low Voltage	V _{IL1}	-0.3	0.8	V	
JTAG Output High Voltage	V _{OH1}	2.4	-	V	I _{OH1} =2mA
JTAG Output Low Voltage	V _{OL1}	-	0.4	V	I _{OL1} =2mA
JTAG Output High Voltage	V _{OH2}	2.9	-	V	I _{OH2} =100uA
JTAG Output Low Voltage	V _{OL2}	-	0.2	V	I _{OL2} =100uA
JTAG Input Load Current	I _X	-10	+10	uA	0 d Vin d V _{DD}

Notes:

- All voltages referenced to VSS (GND); All JTAG inputs and outputs are LVTTTL-compatible.

JTAG TAP DC ELECTRICAL CHARACTERISTICS (V_{DDQ}=2.5V Operating Range)

Parameter	Symbol	Min	Max	Units	Notes
JTAG Input High Voltage	V _{IH1}	1.7	V _{DD} +0.3	V	
JTAG Input Low Voltage	V _{IL1}	-0.3	0.7	V	
JTAG Output High Voltage	V _{OH1}	2.0	-	V	I _{OH1} =2mA
JTAG Output Low Voltage	V _{OL1}	-	0.4	V	I _{OL1} =2mA
JTAG Output High Voltage	V _{OH2}	2.1	-	V	I _{OH2} =100uA
JTAG Output Low Voltage	V _{OL2}	-	0.2	V	I _{OL2} =100uA
JTAG Input Load Current	I _X	-10	+10	uA	0 d Vin d V _{DD}

Notes:

- All voltages referenced to VSS (GND); All JTAG inputs and outputs are LVTTTL-compatible.

JTAG AC Test Conditions

(Over the Operating Temperature Range)

Parameter	Symbol	2.5V Option	3.3V Option	Units
Input Pulse High Level	V _{IH1}	2.5	3.0	V
Input Pulse Low Level	V _{IL1}	0	0	V
Input rise and fall time	T _{R1}	1.5	1.5	ns
Test load termination supply voltage	V _{REF}	1.25	1.5	V
Input and Output Timing Reference Level	V _{REF}	1.25	1.5	V

TAP Output Load Equivalent

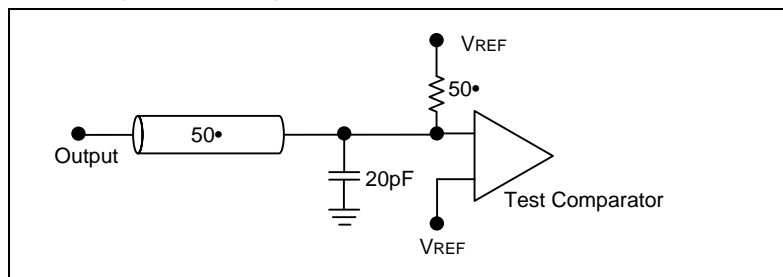

**IS61(4)LF12836EC/IS61(4)VF12836EC/IS61(4)LF12832EC
IS61(4)VF12832EC/IS61(4)LF25618EC/IS61(4)VF25618EC**



JTAG AC Characteristics

(Over the Operating Temperature Range)

Parameter	Symbol	Min	Max	Units
TCK cycle time	t_{THTH}	100	–	ns
TCK high pulse width	t_{THHL}	40	–	ns
TCK low pulse width	t_{TLTH}	40	–	ns
TMS Setup	t_{MVTH}	10	–	ns
TMS Hold	t_{THMX}	10	–	ns
TDI Setup	t_{DVTH}	10	–	ns
TDI Hold	t_{THDX}	10	–	ns
TCK Low to Valid Data*	t_{TLOV}	–	20	ns

JTAG Timing Diagram

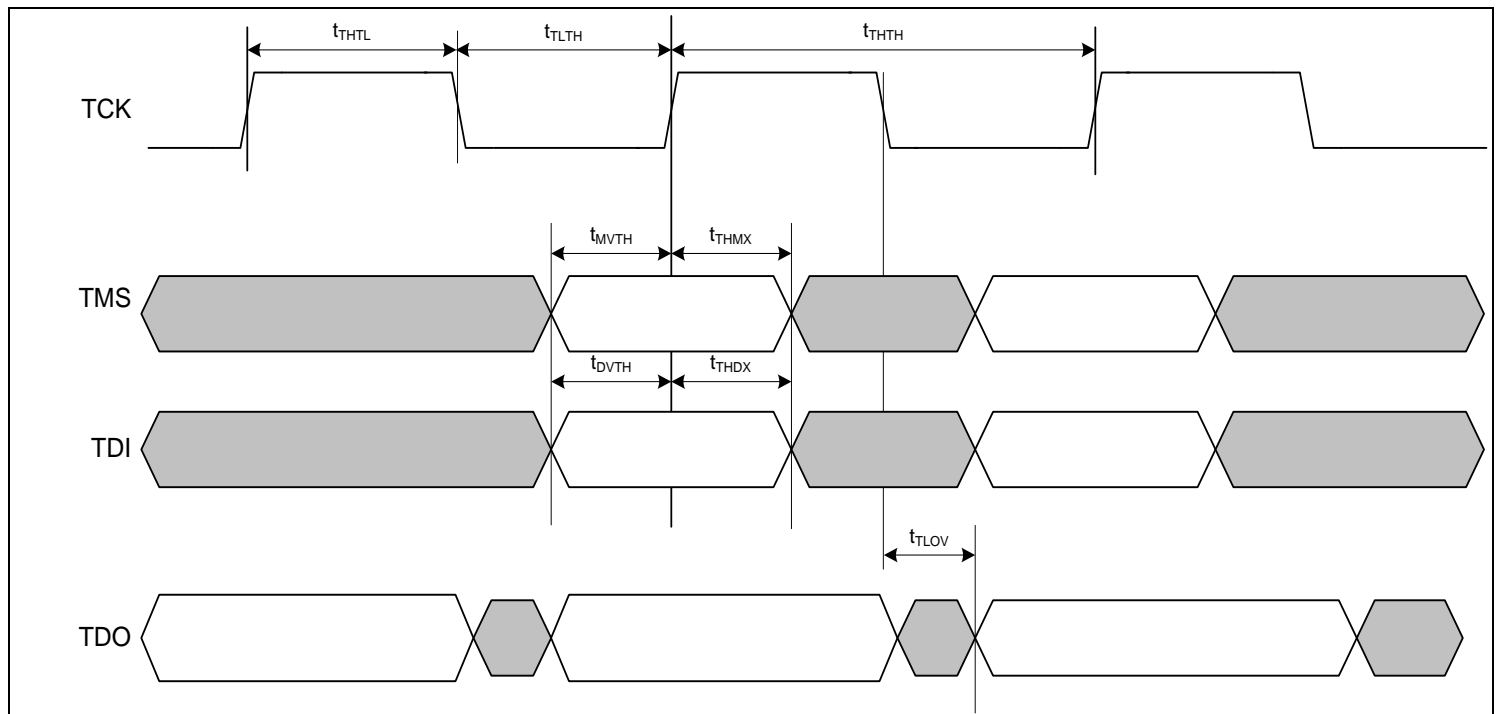



Instruction Set

Code	Instruction	TDO Output	Notes
000	EXTEST	Boundary Scan Register	2, 6
001	IDCODE	32-bit Identification Register	
010	SAMPLE-Z	Boundary Scan Register	1, 2
011	PRIVATE	Do Not Use	5
100	SAMPLE(/PRELOAD)	Boundary Scan Register	4
101	PRIVATE	Do Not Use	5
110	PRIVATE	Do Not Use	5
111	BYPASS	Bypass Register	3

Notes:

1. Places Qs in high-Z in order to sample all input data, regardless of other SRAM inputs.
2. TDI is sampled as an input to the first ID register to allow for the serial shift of the external TDI data.
3. BYPASS register is initiated to V_{SS} when BYPASS instruction is invoked. The BYPASS register also holds the last serially loaded TDI when exiting the shift-DR state.
4. SAMPLE instruction does not place Qs in high-Z.
5. This instruction is reserved. Invoking this instruction will cause improper SRAM functionality.
6. This EXTEST is not IEEE 1149.1-compliant. By default, it places Q in high-Z. If the internal register on the scan chain is set high, Q will be updated with information loaded via a previous SAMPLE instruction. The actual transfer occurs during the update IR state after EXTEST is loaded. The value of the internal register can be changed during SAMPLE and EXTEST only.

ID Register Definition

Instruction Field	Description	128K x 36/32	256K x 18
Revision Number (31:28)	Reserved for version number.	xxxx	xxxx
Device Depth (27:23)	Defines depth of SRAM. 128K or 256K	00110	00111
Device Width (22:18)	Defines Width of the SRAM. x36/32 or x18	00100	00011
ISSI Device ID (17:12)	Reserved for future use.	xxxxx	xxxxx
ISSI JEDEC ID (11:1)	Allows unique identification of SRAM vendor.	00011010101	00011010101
ID Register Presence (0)	Indicate the presence of an ID register.	1	1

**IS61(4)LF12836EC/IS61(4)VF12836EC/IS61(4)LF12832EC
IS61(4)VF12832EC/IS61(4)LF25618EC/IS61(4)VF25618EC**



Boundary Scan Order

165 BGA					119 BGA				
X36/32		X18			X36/32		X18		
Bit #	Signal	Bump ID	Signal	Bump ID	Bit #	Signal	Bump ID	Signal	Bump ID
1	MODE	1R	MODE	1R	1	MODE	3R	MODE	3R
2	NC	6N	NC	6N	2	NC	4L	NC	4L
3	NC	11P	NC	11P	3	NC	7R	NC	7R
4	A	8P	A	8P	4	A	4T	A	2T
5	A	8R	A	8R	5	A	3T	A	3T
6	A	9R	A	9R	6	A	5B	A	5B
7	A	9P	A	9P	7	A	5C	A	5C
8	A	10P	A	10P	8	A	5A	A	5A
9	A	10R	A	10R	9	A	5T	A	5T
10	A	11R	A	11R	10	A	6R	A	6R
11	ZZ	11H	ZZ	11H	11	ZZ	7T	ZZ	7T
12	DQPa	11N	NC	11N	12	DQPa	6P	NC	6P
13	DQa	11M	NC	11M	13	DQa	7N	NC	7N
14	DQa	11L	NC	11L	14	DQa	6M	NC	6M
15	DQa	11K	NC	11K	15	DQPa	7P	NC	7L
16	DQa	11J	NC	11J	16	DQa	6N	NC	6K
17	DQa	10M	DQa	10M	17	DQa	7L	DQa	7P
18	DQa	10L	DQa	10L	18	DQa	6K	DQa	6N
19	DQa	10K	DQa	10K	19	DQa	6L	DQa	6L
20	DQa	10J	DQa	10J	20	DQa	7K	DQa	7K
21	DQb	11G	DQa	11G	21	DQb	6H	DQa	6H
22	DQb	11F	DQa	11F	22	DQb	7G	DQa	7G
23	DQb	11E	DQa	11E	23	DQb	7H	DQa	6F
24	DQb	11D	DQa	11D	24	DQb	6F	DQa	7E
25	DQb	10G	DQPa	11C	25	DQb	7E	DQPa	6D
26	DQb	10F	NC	10F	26	DQb	6G	NC	6G
27	DQb	10E	NC	10E	27	DQb	6E	NC	6E
28	DQb	10D	NC	10D	28	DQb	7D	NC	7D
29	DQPb	11C	NC	10G	29	DQPb	6D	NC	7H
30	NC	11A	A	11A	30	NC	6T	A	6T
31	A	10A	A	10A	31	A	6A	A	6A
32	A	10B	A	10B	32	A	6C	A	6C
33	/ADV	9A	/ADV	9A	33	/ADV	4G	/ADV	4G
34	/ADSP	9B	/ADSP	9B	34	/ADSP	4A	/ADSP	4A
35	/ADSC	8A	/ADSC	8A	35	/ADSC	4B	/ADSC	4B
36	/OE	8B	/OE	8B	36	/OE	4F	/OE	4F
37	/BWE	7A	/BWE	7A	37	/BWE	4M	/BWE	4M
38	/GW	7B	/GW	7B	38	/GW	4H	/GW	4H
39	CLK	6B	CLK	6B	39	CLK	4K	CLK	4K
40	NC	11B	NC	11B	40	NC	7C	NC	7C

Continue next page

165 BGA					119 BGA				
---------	--	--	--	--	---------	--	--	--	--

**IS61(4)LF12836EC/IS61(4)VF12836EC/IS61(4)LF12832EC
IS61(4)VF12832EC/IS61(4)LF25618EC/IS61(4)VF25618EC**



X36/32		X18		X36/32		X18			
Bit #	Signal	Bump ID	Signal	Bump ID	Bit #	Signal	Bump ID	Signal	Bump ID
41	NC	1A	NC	1A	41	NC	1B	NC	1B
42	/CE2	6A	/CE2	6A	42	/CE2	6B	/CE2	6B
43	/BWa	5B	/BWa	5B	43	/BWa	5L	/BWa	5L
44	/BWb	5A	NC	5A	44	/BWb	5G	NC	5G
45	/BWc	4A	/BWb	4A	45	/BWc	3G	/BWb	3G
46	/BWd	4B	NC	4B	46	/BWd	3L	NC	3L
47	CE2	3B	CE2	3B	47	CE2	2B	CE2	2B
48	/CE	3A	/CE	3A	48	/CE	4E	/CE	4E
49	A	2A	A	2A	49	A	3A	A	3A
50	A	2B	A	2B	50	A	2A	A	2A
51	NC	1B	NC	1B	51	NC	1C	NC	1C
52	DQPc	1C	NC	1C	52	DQPc	2D	NC	2D
53	DQc	1D	NC	1D	53	DQc	1E	NC	1E
54	DQc	1E	NC	1E	54	DQc	2F	NC	2F
55	DQc	1F	NC	1F	55	DQc	1D	NC	1G
56	DQc	1G	NC	1G	56	DQc	2E	NC	2H
57	DQc	2D	DQb	2D	57	DQc	1G	DQb	1D
58	DQc	2E	DQb	2E	58	DQc	2H	DQb	2E
59	DQc	2F	DQb	2F	59	DQc	2G	DQb	2G
60	DQc	2G	DQb	2G	60	DQc	1H	DQb	1H
61	DQd	1J	DQb	1J	61	DQd	2K	DQb	2K
62	DQd	1K	DQb	1K	62	DQd	1L	DQb	1L
63	DQd	1L	DQb	1L	63	DQd	1K	DQb	2M
64	DQd	1M	DQb	1M	64	DQd	2M	DQb	1N
65	DQd	2J	DQPb	1N	65	DQd	1N	DQPb	2P
66	DQd	2K	NC	2K	66	DQd	2L	NC	2L
67	DQd	2L	NC	2L	67	DQd	2N	NC	2N
68	DQd	2M	NC	2M	68	DQd	1P	NC	1P
69	DQPd	1N	NC	2J	69	DQPd	2P	NC	1K
70	A	3P	A	3P	70	A	2R	A	2R
71	A	3R	A	3R	71	A	2C	A	2C
72	A	4R	A	4R	72	A	3B	A	3B
73	A	4P	A	4P	73	A	3C	A	3C
74	A1	6P	A1	6P	74	A1	4N	A1	4N
75	A0	6R	A0	6R	75	A0	4P	A0	4P

Note : DQP_a, DQP_b, DQP_c, and DQP_d pins of x36 IO option are NC of x32 IO option.



ORDERING INFORMATION

The ordering code information of the product family

IS Product Function Density Version – Speed Package Temperature

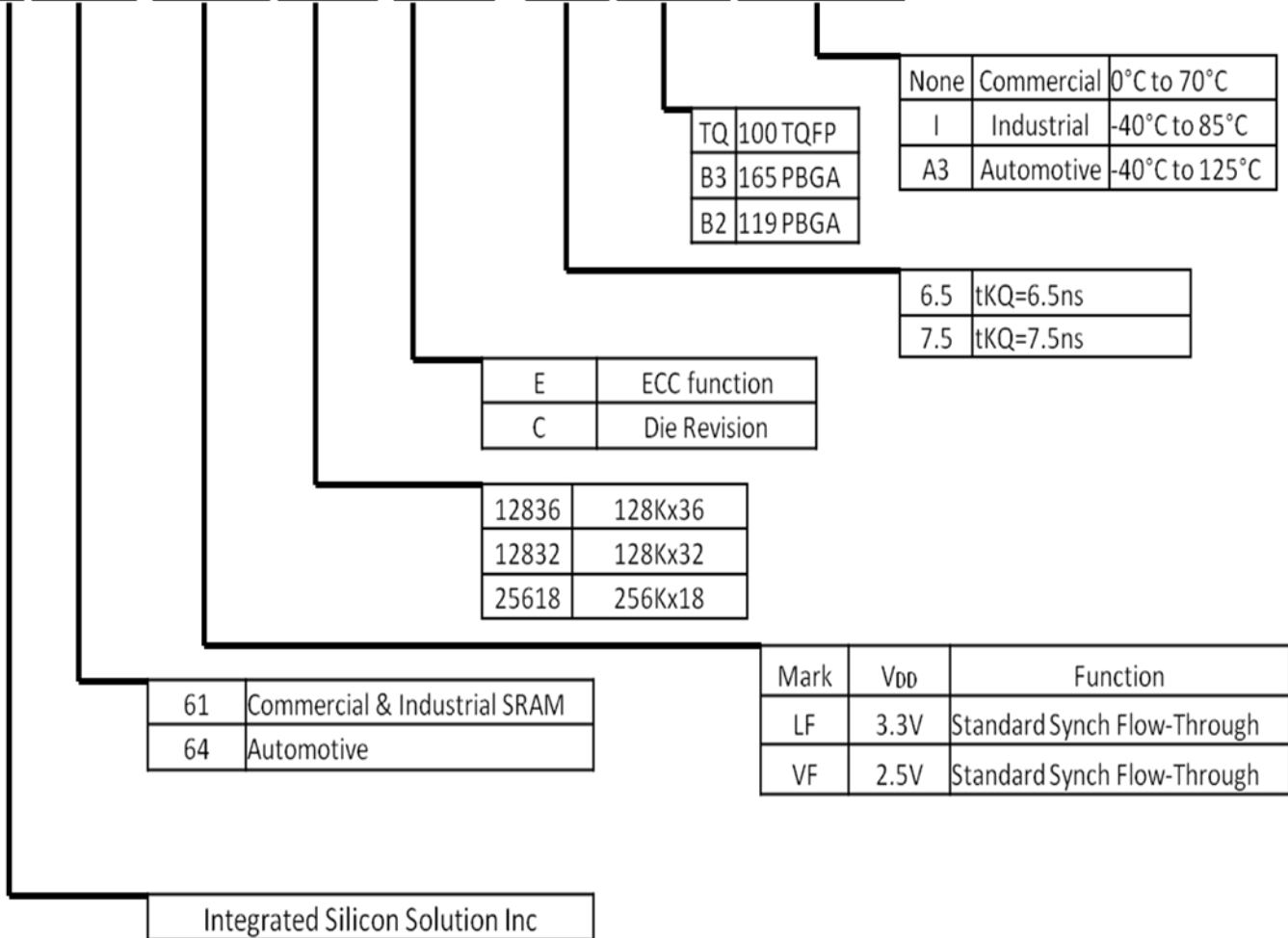

**IS61(4)LF12836EC/IS61(4)VF12836EC/IS61(4)LF12832EC
IS61(4)VF12832EC/IS61(4)LF25618EC/IS61(4)VF25618EC**



Commercial Range: 0°C to 70°C

VDD	SPEED	X36	X32	X18	Package		
VDD =3.3V VDDQ=2.5V or VDDQ=3.3V	6.5ns	IS61LF12836EC-6.5TQ	IS61LF12832EC-6.5TQ	IS61LF25618EC-6.5TQ	100 QFP		
		IS61LF12836EC-6.5B3	IS61LF12832EC-6.5B3	IS61LF25618EC-6.5B3	165 BGA		
		IS61LF12836EC-6.5B2	IS61LF12832EC-6.5B2	IS61LF25618EC-6.5B2	119 BGA		
		IS61LF12836EC-6.5TQL	IS61LF12832EC-6.5TQL	IS61LF25618EC-6.5TQL	100 QFP, Lead-free		
		IS61LF12836EC-6.5B3L	IS61LF12832EC-6.5B3L	IS61LF25618EC-6.5B3L	165 BGA, Lead-free		
		IS61LF12836EC-6.5B2L	IS61LF12832EC-6.5B2L	IS61LF25618EC-6.5B2L	119 BGA, Lead-free		
	7.5ns	IS61LF12836EC-7.5TQ	IS61LF12832EC-7.5TQ	IS61LF25618EC-7.5TQ	100 QFP		
		IS61LF12836EC-7.5B3	IS61LF12832EC-7.5B3	IS61LF25618EC-7.5B3	165 BGA		
		IS61LF12836EC-7.5B2	IS61LF12832EC-7.5B2	IS61LF25618EC-7.5B2	119 BGA		
		IS61LF12836EC-7.5TQL	IS61LF12832EC-7.5TQL	IS61LF25618EC-7.5TQL	100 QFP, Lead-free		
		IS61LF12836EC-7.5B3L	IS61LF12832EC-7.5B3L	IS61LF25618EC-7.5B3L	165 BGA, Lead-free		
		IS61LF12836EC-7.5B2L	IS61LF12832EC-7.5B2L	IS61LF25618EC-7.5B2L	119 BGA, Lead-free		
		VDD =2.5V VDDQ=2.5V	6.5ns	IS61VF12836EC-6.5TQ	IS61VF12832EC-6.5TQ	IS61VF25618EC-6.5TQ	100 QFP
				IS61VF12836EC-6.5B3	IS61VF12832EC-6.5B3	IS61VF25618EC-6.5B3	165 BGA
IS61VF12836EC-6.5B2	IS61VF12832EC-6.5B2			IS61VF25618EC-6.5B2	119 BGA		
IS61VF12836EC-6.5TQL	IS61VF12832EC-6.5TQL			IS61VF25618EC-6.5TQL	100 QFP, Lead-free		
IS61VF12836EC-6.5B3L	IS61VF12832EC-6.5B3L			IS61VF25618EC-6.5B3L	165 BGA, Lead-free		
IS61VF12836EC-6.5B2L	IS61VF12832EC-6.5B2L			IS61VF25618EC-6.5B2L	119 BGA, Lead-free		
7.5ns	IS61VF12836EC-7.5TQ		IS61VF12832EC-7.5TQ	IS61VF25618EC-7.5TQ	100 QFP		
	IS61VF12836EC-7.5B3		IS61VF12832EC-7.5B3	IS61VF25618EC-7.5B3	165 BGA		
	IS61VF12836EC-7.5B2		IS61VF12832EC-7.5B2	IS61VF25618EC-7.5B2	119 BGA		
	IS61VF12836EC-7.5TQL		IS61VF12832EC-7.5TQL	IS61VF25618EC-7.5TQL	100 QFP, Lead-free		
		IS61VF12836EC-7.5B3L	IS61VF12832EC-7.5B3L	IS61VF25618EC-7.5B3L	165 BGA, Lead-free		
		IS61VF12836EC-7.5B2L	IS61VF12832EC-7.5B2L	IS61VF25618EC-7.5B2L	119 BGA, Lead-free		

**IS61(4)LF12836EC/IS61(4)VF12836EC/IS61(4)LF12832EC
IS61(4)VF12832EC/IS61(4)LF25618EC/IS61(4)VF25618EC**



Industrial Range: -40°C to 85°C

VDD	SPEED	X36	X32	X18	Package
VDD =3.3V VDDQ=2.5V or VDDQ=3.3V	6.5ns	IS61LF12836EC-6.5TQI	IS61LF12832EC-6.5TQI	IS61LF25618EC-6.5TQI	100 QFP
		IS61LF12836EC-6.5B3I	IS61LF12832EC-6.5B3I	IS61LF25618EC-6.5B3I	165 BGA
		IS61LF12836EC-6.5B2I	IS61LF12832EC-6.5B2I	IS61LF25618EC-6.5B2I	119 BGA
		IS61LF12836EC-6.5TQLI	IS61LF12832EC-6.5TQLI	IS61LF25618EC-6.5TQLI	100 QFP, Lead-free
		IS61LF12836EC-6.5B3LI	IS61LF12832EC-6.5B3LI	IS61LF25618EC-6.5B3LI	165 BGA, Lead-free
	7.5ns	IS61LF12836EC-6.5B2LI	IS61LF12832EC-6.5B2LI	IS61LF25618EC-6.5B2LI	119 BGA, Lead-free
		IS61LF12836EC-7.5TQI	IS61LF12832EC-7.5TQI	IS61LF25618EC-7.5TQI	100 QFP
		IS61LF12836EC-7.5B3I	IS61LF12832EC-7.5B3I	IS61LF25618EC-7.5B3I	165 BGA
		IS61LF12836EC-7.5B2I	IS61LF12832EC-7.5B2I	IS61LF25618EC-7.5B2I	119 BGA
		IS61LF12836EC-7.5TQLI	IS61LF12832EC-7.5TQLI	IS61LF25618EC-7.5TQLI	100 QFP, Lead-free
VDD =2.5V VDDQ=2.5V	6.5ns	IS61VF12836EC-6.5TQI	IS61VF12832EC-6.5TQI	IS61VF25618EC-6.5TQI	100 QFP
		IS61VF12836EC-6.5B3I	IS61VF12832EC-6.5B3I	IS61VF25618EC-6.5B3I	165 BGA
		IS61VF12836EC-6.5B2I	IS61VF12832EC-6.5B2I	IS61VF25618EC-6.5B2I	119 BGA
		IS61VF12836EC-6.5TQLI	IS61VF12832EC-6.5TQLI	IS61VF25618EC-6.5TQLI	100 QFP, Lead-free
		IS61VF12836EC-6.5B3LI	IS61VF12832EC-6.5B3LI	IS61VF25618EC-6.5B3LI	165 BGA, Lead-free
	7.5ns	IS61VF12836EC-6.5B2LI	IS61VF12832EC-6.5B2LI	IS61VF25618EC-6.5B2LI	119 BGA, Lead-free
		IS61VF12836EC-7.5TQI	IS61VF12832EC-7.5TQI	IS61VF25618EC-7.5TQI	100 QFP
		IS61VF12836EC-7.5B3I	IS61VF12832EC-7.5B3I	IS61VF25618EC-7.5B3I	165 BGA
		IS61VF12836EC-7.5B2I	IS61VF12832EC-7.5B2I	IS61VF25618EC-7.5B2I	119 BGA
		IS61VF12836EC-7.5TQLI	IS61VF12832EC-7.5TQLI	IS61VF25618EC-7.5TQLI	100 QFP, Lead-free
		IS61VF12836EC-7.5B3LI	IS61VF12832EC-7.5B3LI	IS61VF25618EC-7.5B3LI	165 BGA, Lead-free
		IS61VF12836EC-7.5B2LI	IS61VF12832EC-7.5B2LI	IS61VF25618EC-7.5B2LI	119 BGA, Lead-free

**IS61(4)LF12836EC/IS61(4)VF12836EC/IS61(4)LF12832EC
IS61(4)VF12832EC/IS61(4)LF25618EC/IS61(4)VF25618EC**



Automotive(A3) Range: -40°C to 125°C

VDD	SPEED	X36	X32	X18	Package		
VDD =3.3V VDDQ=2.5V or VDDQ=3.3V	6.5ns	IS64LF12836EC-6.5TQA3	IS64LF12832EC-6.5TQA3	IS64LF25618EC-6.5TQA3	100 QFP		
		IS64LF12836EC-6.5B3A3	IS64LF12832EC-6.5B3A3	IS64LF25618EC-6.5B3A3	165 BGA		
		IS64LF12836EC-6.5B2A3	IS64LF12832EC-6.5B2A3	IS64LF25618EC-6.5B2A3	119 BGA		
		IS64LF12836EC-6.5TQLA3	IS64LF12832EC-6.5TQLA3	IS64LF25618EC-6.5TQLA3	100 QFP, Lead-free		
		IS64LF12836EC-6.5B3LA3	IS64LF12832EC-6.5B3LA3	IS64LF25618EC-6.5B3LA3	165 BGA, Lead-free		
	7.5ns	6.5ns	IS64LF12836EC-6.5B2LA3	IS64LF12832EC-6.5B2LA3	IS64LF25618EC-6.5B2LA3	119 BGA, Lead-free	
			IS64LF12836EC-7.5TQA3	IS64LF12832EC-7.5TQA3	IS64LF25618EC-7.5TQA3	100 QFP	
			IS64LF12836EC-7.5B3A3	IS64LF12832EC-7.5B3A3	IS64LF25618EC-7.5B3A3	165 BGA	
			IS64LF12836EC-7.5B2A3	IS64LF12832EC-7.5B2A3	IS64LF25618EC-7.5B2A3	119 BGA	
			IS64LF12836EC-7.5TQLA3	IS64LF12832EC-7.5TQLA3	IS64LF25618EC-7.5TQLA3	100 QFP, Lead-free	
		7.5ns	6.5ns	IS64LF12836EC-7.5B3LA3	IS64LF12832EC-7.5B3LA3	IS64LF25618EC-7.5B3LA3	165 BGA, Lead-free
				IS64LF12836EC-7.5B2LA3	IS64LF12832EC-7.5B2LA3	IS64LF25618EC-7.5B2LA3	119 BGA, Lead-free
				IS64VF12836EC-6.5TQA3	IS64VF12832EC-6.5TQA3	IS64VF25618EC-6.5TQA3	100 QFP
				IS64VF12836EC-6.5B3A3	IS64VF12832EC-6.5B3A3	IS64VF25618EC-6.5B3A3	165 BGA
				IS64VF12836EC-6.5B2A3	IS64VF12832EC-6.5B2A3	IS64VF25618EC-6.5B2A3	119 BGA
7.5ns	6.5ns	IS64VF12836EC-6.5TQLA3	IS64VF12832EC-6.5TQLA3	IS64VF25618EC-6.5TQLA3	100 QFP, Lead-free		
		IS64VF12836EC-6.5B3LA3	IS64VF12832EC-6.5B3LA3	IS64VF25618EC-6.5B3LA3	165 BGA, Lead-free		
		IS64VF12836EC-6.5B2LA3	IS64VF12832EC-6.5B2LA3	IS64VF25618EC-6.5B2LA3	119 BGA, Lead-free		
		IS64VF12836EC-7.5TQA3	IS64VF12832EC-7.5TQA3	IS64VF25618EC-7.5TQA3	100 QFP		
		IS64VF12836EC-7.5B3A3	IS64VF12832EC-7.5B3A3	IS64VF25618EC-7.5B3A3	165 BGA		
	7.5ns	6.5ns	IS64VF12836EC-7.5B2A3	IS64VF12832EC-7.5B2A3	IS64VF25618EC-7.5B2A3	119 BGA	
			IS64VF12836EC-7.5TQLA3	IS64VF12832EC-7.5TQLA3	IS64VF25618EC-7.5TQLA3	100 QFP, Lead-free	
			IS64VF12836EC-7.5B3LA3	IS64VF12832EC-7.5B3LA3	IS64VF25618EC-7.5B3LA3	165 BGA, Lead-free	
			IS64VF12836EC-7.5B2LA3	IS64VF12832EC-7.5B2LA3	IS64VF25618EC-7.5B2LA3	119 BGA, Lead-free	
			IS64VF12836EC-7.5B2LA3	IS64VF12832EC-7.5B2LA3	IS64VF25618EC-7.5B2LA3	119 BGA, Lead-free	

• Note : Not all automotive options listed are currently available. Please contact ISSI for parts

IS61(4)LF12836EC/IS61(4)VF12836EC/IS61(4)LF12832EC
 IS61(4)VF12832EC/IS61(4)LF25618EC/IS61(4)VF25618EC



PACKAGE OUTLINE DRAWING

100 QFP (14x20x1.4mm)

SYMBOL	DIMENSION IN MM		DIMENSION IN INCH	
	MIN.	MAX.	MIN.	MAX.
A	1.40	1.60	0.055	0.063
A1	0.05	0.15	0.002	0.006
A2	1.35	1.45	0.053	0.057
b	0.22	0.38	0.009	0.015
D	21.90	22.10	0.862	0.870
D1	19.90	20.10	0.783	0.791
E	15.90	16.10	0.626	0.634
E1	13.90	14.10	0.547	0.555
e	0.65 BSC.		0.026 BSC.	
L	0.45	0.60	0.018	0.024
L1	0.25 BSC.		0.010 BSC.	
ZD	0.575 REF.		0.023 REF.	
ZE	0.825 REF.		0.032 REF.	
θ	0	3.5°	0	3.5°

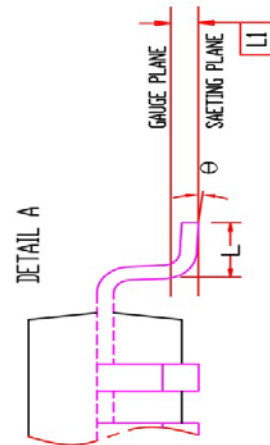
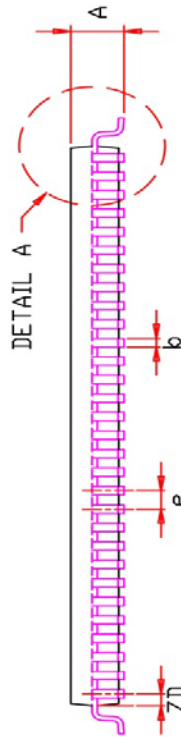
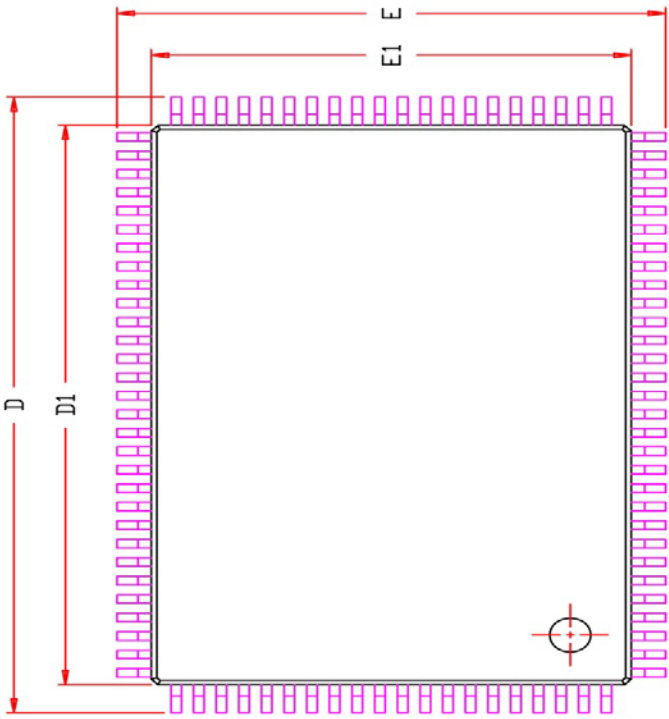
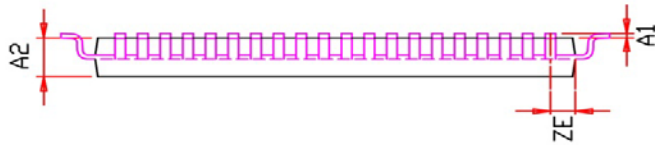

NOTE :

1. CONTROLLING DIMENSION : MM
2. DIMENSION D1 AND E1 DO NOT INCLUDE MOLD PROTRUSION.
3. DIMENSION b DOES NOT INCLUDE DAMBAR PROTRUSION/INTRUSION.

ISSI	TITLE	REV.	DATE
	100L 14x20x1.4mm LQFP (Footprint: 2.0 mm) Package Outline	F	09/01/2009

IS61(4)LF12836EC/IS61(4)VF12836EC/IS61(4)LF12832EC
 IS61(4)VF12832EC/IS61(4)LF25618EC/IS61(4)VF25618EC



119 BGA (14x22x2.15mm)

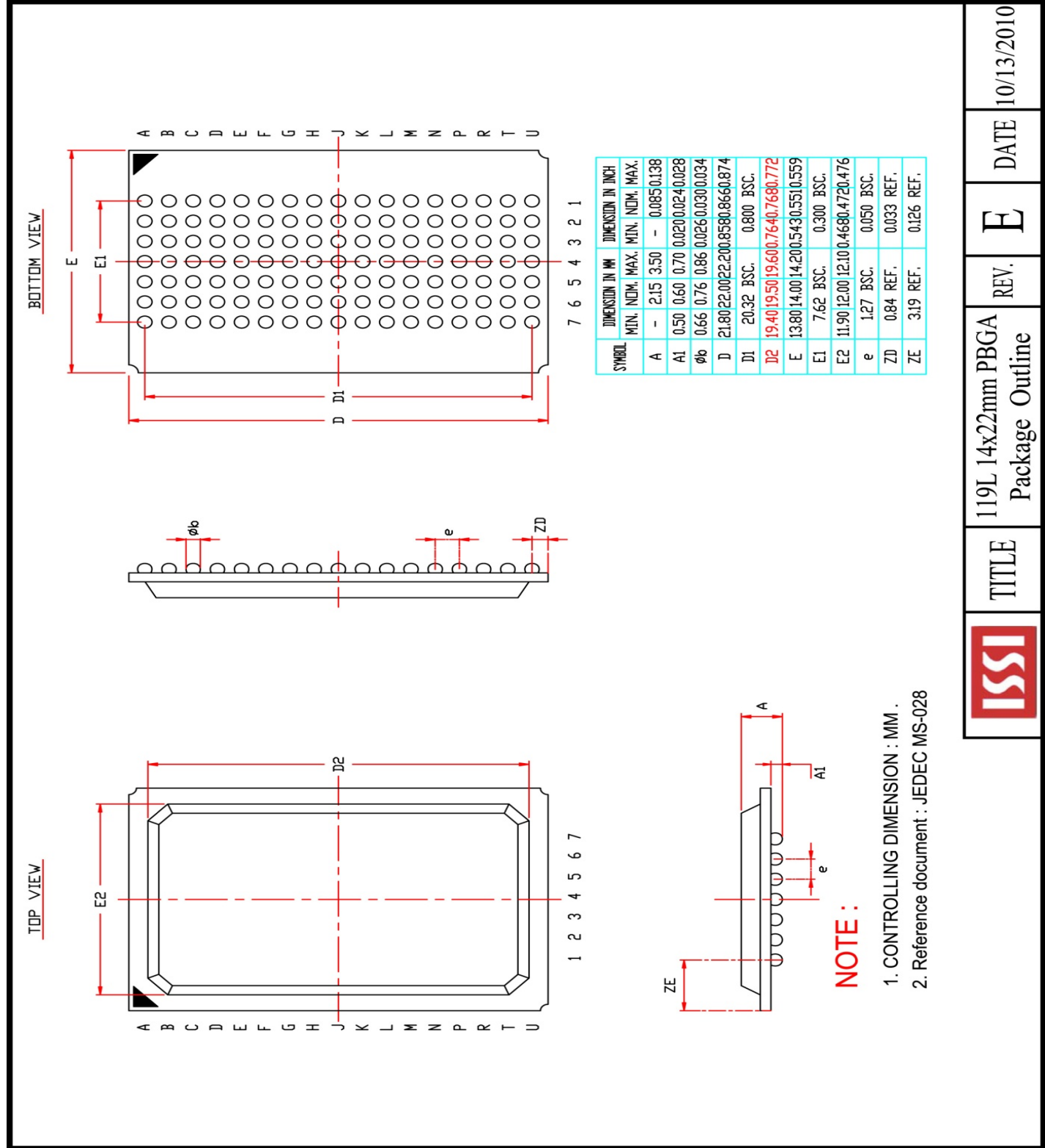

ISSI	TITLE	119L 14x22mm PBGA Package Outline	REV.	E	DATE	10/13/2010
------	-------	--------------------------------------	------	---	------	------------

IS61(4)LF12836EC/IS61(4)VF12836EC/IS61(4)LF12832EC
 IS61(4)VF12832EC/IS61(4)LF25618EC/IS61(4)VF25618EC



165 BGA (13x15x1.2mm)

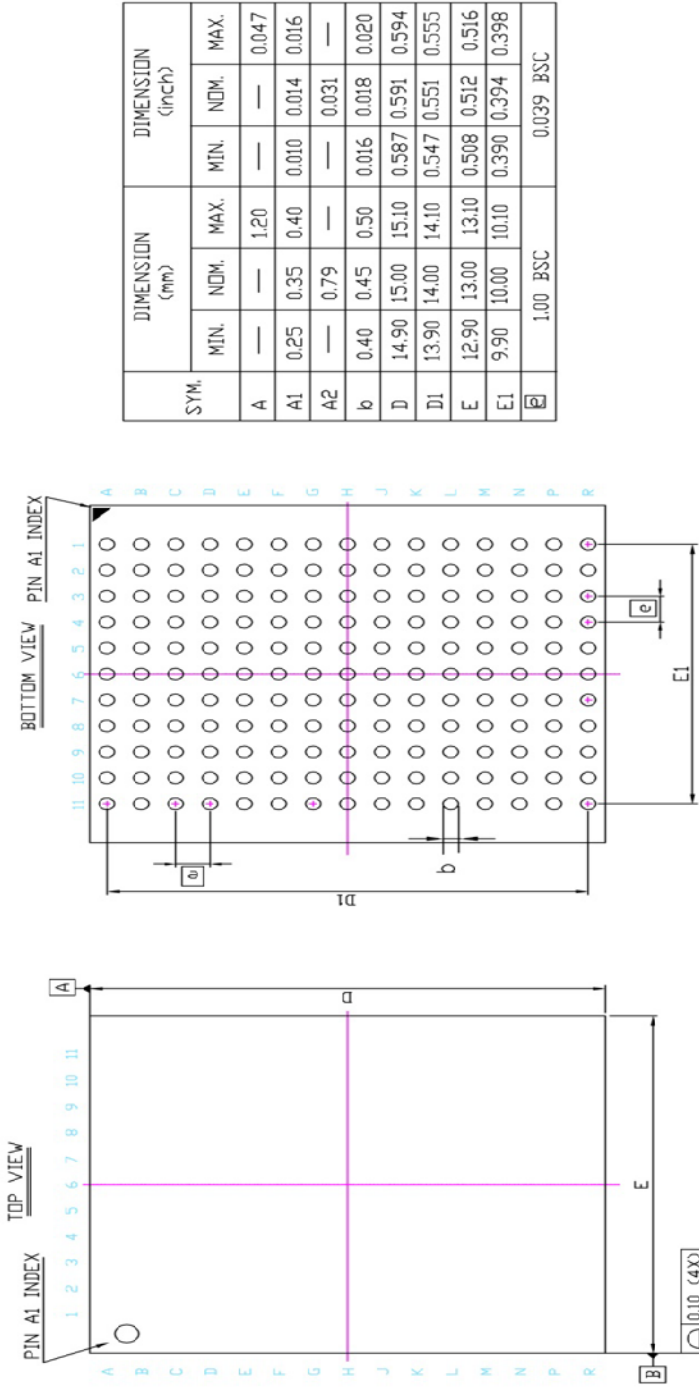

SYM.	DIMENSION (mm)			DIMENSION (inch)		
	MIN.	NDM.	MAX.	MIN.	NDM.	MAX.
A	—	—	1.20	—	—	0.047
A1	0.25	0.35	0.40	0.010	0.014	0.016
A2	—	0.79	—	—	0.031	—
b	0.40	0.45	0.50	0.016	0.018	0.020
D	14.90	15.00	15.10	0.587	0.591	0.594
D1	13.90	14.00	14.10	0.547	0.551	0.555
E	12.90	13.00	13.10	0.508	0.512	0.516
E1	9.90	10.00	10.10	0.390	0.394	0.398
\square	1.00 BSC			0.039 BSC		

NOTE :

1. CONTROLLING DIMENSION : MM .



TITLE

165L 13x15mm TF-BGA
 Package Outline

REV.

B

DATE

08/28/2008