

# ZTP-101T

## Thermopile IR Sensor



This thermopile sensor is used for non-contact surface temperature measuring. The ZTP -101T model consists of thermo-elements, flat IR filter, a thermistor for temperature compensation and a hermetically-sealed small-size package. There is also a variety of filters available to maximize performance in specific applications

### Applications

- Patient monitoring
- Ear & Tympanic thermometers
- Occupancy detection
- HVAC
- Appliance

### Features

- Non-contact measurement
- Wider surface area measurement
- Small-size sensor package
- Included ambient temperature - (thermistor) sensor for compensation
- High sensitivity
- Fast response time
- Low cost



# Specifications

## Thermopile Chip

Parameter	Limits			Units	Condition
	Min	Typ	Max		
Chip Size		3.0 X 3.0		mm <sup>2</sup>	
Diaphragm Size		1.5 x 1.5		mm <sup>2</sup>	
Active Area		0.51 x 0.51		mm <sup>2</sup>	
Internal Resistance	140	200	260	kΩ	25°C
Resistance T.C			0.10	%/°C	
Responsivity	77	110	143	V/W	500K, 1 Hz
Responsivity T.C		-0.11		%/°C	
Noise Voltage		62		nV rms	R.M.S., 25°C
NEP		0.60		nW/Hz <sup>1/2</sup>	500K, 1 Hz
Detectivity		9.00 E07		cmHz <sup>1/2</sup> /W	500K, 1 Hz
Time Constant		22		ms	

## Thermistor for Temperature Compensation

Parameter	Limits			Units	Condition
	Min	Typ	Max		
Resistance	29.1	30	30.9	kΩ	Tol. :3%, @25°C
Beta - Value	3773	3811	3849	K	Tol. :1%, Defined at 0°C/50°C

## Absolute Maximum Ratings

### Operating Temperature

-20°C ~ 100°C

### Storage Temperature

-40°C ~ 120°C

## Thermistor Resistance (R-T Table)

T ambient (° C)	Rmin (kΩ)	Rcent (kΩ)	Rmax (kΩ)
-40	267	284.7	303.2
-35	197.2	209.6	222.5
-30	147.1	155.9	165
-25	110.8	117.1	123.6
-20	84.16	88.68	93.35
-15	64.46	67.73	71.11
-10	49.74	52.13	54.59
-5	38.65	40.41	42.21
0	30.24	31.54	32.86
5	23.81	24.77	25.75
10	18.86	19.58	20.3
15	15.03	15.56	16.1
20	12.04	12.44	12.84
25	9.7	10	10.3
30	7.823	8.082	8.342
35	6.342	6.566	6.791
40	5.168	5.361	5.557
45	4.233	4.4	4.569
50	3.484	3.629	3.776
55	2.882	3.007	3.135
60	2.396	2.504	2.615
65	2.0009	2.095	2.192
70	1.679	1.7612	1.8458
75	1.4153	1.4871	1.5612
80	1.1984	1.261	1.3264
85	1.0193	1.0745	1.1317
90	0.8707	0.9193	0.9697
95	0.7469	0.7898	0.8344
100	0.6433	0.6812	0.7208
105	0.5562	0.5899	0.625

## Sensitivity

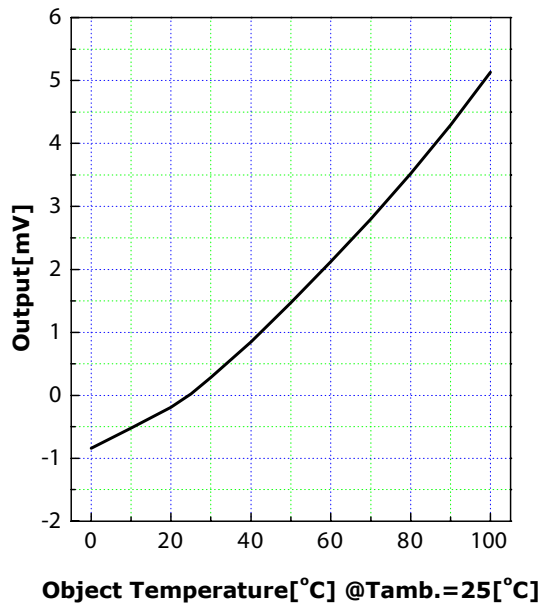

## Field of View

Parameter	Limits			Units	Condition
	Min	Typ	Max		
Field of View	45	50	55	Degree	50% of Maximum Output

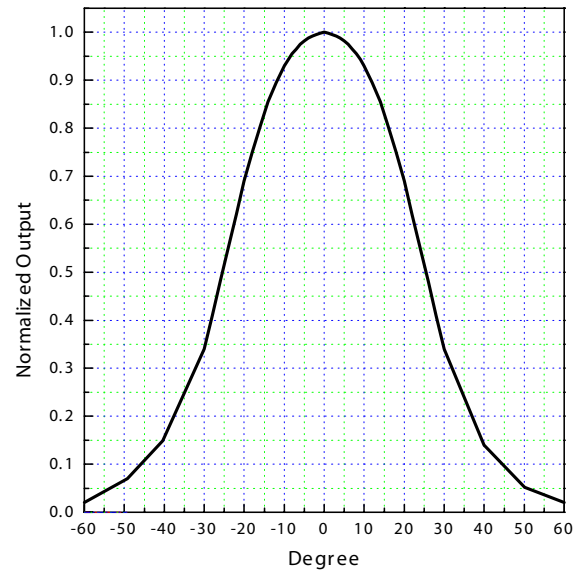

## Transmission Data of Filter

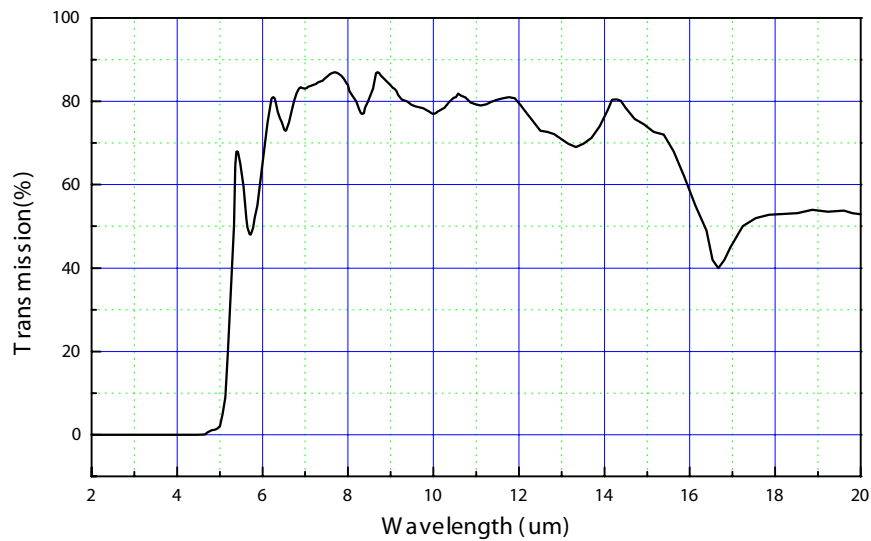

# Outline of Sensor Packaging and Pin Arrangement (unit = mm)

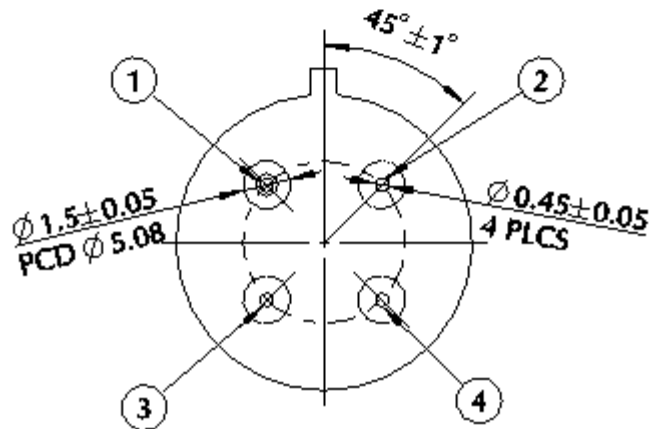
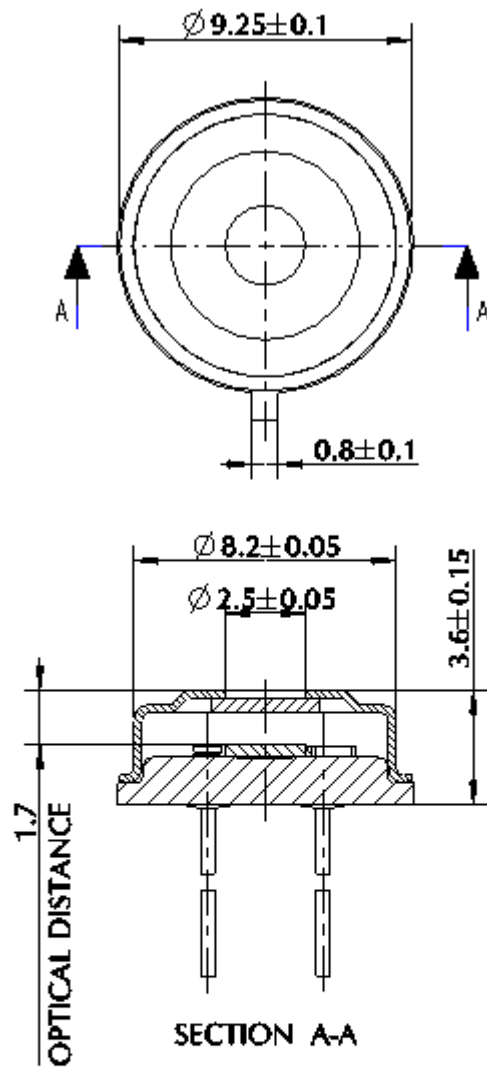

Unit: mm

Pin arrangement:  
 1. GND Thermistor  
 2. Thermopile  
 3. GND Thermopile  
 4. Thermistor



[www.ge-mcs.com](http://www.ge-mcs.com)

920-548A