

The 62201-7400 RAST 2.5 Discrete Wire Manual Press Terminator is designed to terminate the RAST 2.5 Connector Series 90871 and 90872. This series of connectors is designed to be terminated onto discrete 0.22mm 2 or 0.38mm2 wire.

These connectors are available in continuous chains or "stacks" which are connected by tabs that are cut apart during termination. This tooling system will accommodate from 2 through 20 circuits and is designed for low to medium production volumes. This tool can produce up to 450 terminated discrete wires per hour depending on operator skill.

Operation

The operator loads a connector into the nest and inserts the wires into position. The operator then pulls down on the press lever, terminating the connector and wires. The operator then removes the harness and the process is complete.

Features and Benefits

- Accepts 2 through 20 circuit connectors, providing production flexibility
- All operations are manual and require no air or electric feeds. This provides energy savings and requires no machine installation, which lowers cost
- Lightweight design, which provides for easy storage and relocation

Mechanical

Dimensions: Height—525.00mm (20.70")
 Width—210.00mm (08.30")
 Depth—136.00mm (05.40") without connector support
 480.00mm (18.90") with connector support
 Weight: Gross—18.10kg (40 lbs)
 Processing Capability: 450 discrete wires per hour depending on operator skill

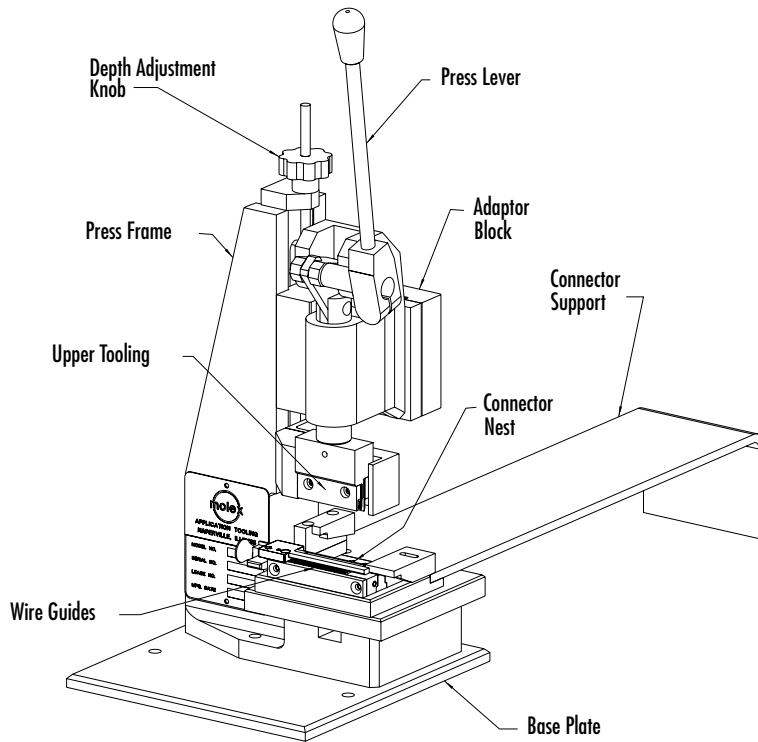

ORDERING INFORMATION

Order No.	Description	For Use With
62201-7400	RAST 2.5 Manual Press	90871, 90872

Americas Headquarters
 Lisle, Illinois 60532 U.S.A.
 1-800-78MOLEX
 amerinfo@molex.com

Far East North Headquarters
 Yamato, Kanagawa, Japan
 81-462-65-2324
 feninfo@molex.com

Far East South Headquarters
 Jurong, Singapore
 65-6-268-6868
 fesinfo@molex.com

European Headquarters
 Munich, Germany
 49-89-413092-0
 eurinfo@molex.com

Corporate Headquarters
 2222 Wellington Ct.
 Lisle, IL 60532 U.S.A.
 630-969-4550
 Fax: 630-969-1352