

SPECIFICATION CONTROL DRAWING

REQUIREMENTS:

DIMENSIONS (FIGURE 1), DESIGN CHARACTERISTICS, AND CONFIGURATION MEET THE REQUIREMENTS OF M39029/76 EXCEPT THAT THE TEMPERATURE RATING IS 125°C INSTEAD OF 200°C, TERMINATION IS BY SOLDERING INSTEAD OF CRIMPING. SEE TABLE I FOR CABLE ACCOMMODATION.

THIS CONTACT IS QUALIFIED TO RAYCHEM SPECIFICATION D-6002.

MATING CONTACT: D-602-0171-C8898 (M39029/78)

TOOLS: SEE TABLE II.

TABLE I. DESIGN CHARACTERISTICS

CABLE ACCOMMODATED <u>1/</u>	CONTACT CAVITY SIZE	TYPE	CLASS
RAYCHEM 10598-30-9X	16	D	A

1/ THE CONTACT TERMINATES THE CENTER CONDUCTOR AND INNER SHIELD OF THIS TRIAXIAL CABLE.

OTHER APPLICATIONS USING DIFFERENT CABLES MAY BE ACCOMMODATED. CONSULT CONTACT MANUFACTURER FOR DETAILS.

TABLE II. TOOLS

HEATING TOOLS <u>2/</u>	REFLECTORS <u>2/</u>	STANDARD FIXTURE <u>2/</u>		REPAIR FIXTURE <u>2/</u>	INSTALLING TOOLS *	REMOVAL TOOLS *
		BASIC FIXTURE	ADAPTER			
AA-400 SUPER HEATER	#979663 MINI SOLDER SLEEVE	AD-1319 OR AD1567	AT-1319-78 OR AT-1319-27	AD-1565	M81969/8-07 OR M81969/14-03	M81969/8-08 OR M81969/14-03
STEINEL HLI802E	STEINEL SOLDERSLEEVE				OR DANIELS MFG. DAK83-16 (METAL)	OR DANIELS MFG. DAK83-16 (METAL)

2/ SEE RAYCHEM ES-61226 FOR TERMINATION PROCEDURE INSTRUCTIONS EXCEPT THE STRIP LENGTH TO BE AS SHOWN ON PAGE# 3.

* THIS CABLE MAY REQUIRE THE USE OF THE METAL TOOL FOR PROPER HANDLING.

**If this document is printed it becomes uncontrolled.
Check with the web for latest revision.**

DOCUMENT NUMBER: D-602-0140-C8898	
CAD NAME: T29713B.DWG	SHEET 2 of 5

SPECIFICATION CONTROL DRAWING

ASSEMBLY INSTRUCTIONS

1. STRIP CABLE AS SHOWN. PRE-TIN CENTER CONDUCTOR.
2. INSERT CABLE INTO CONTACT UNTIL IT IS FULLY SEATED.
3. HEAT CONTACT WITH APPROPRIATE TOOLS AS SHOWN ON TABLE II UNTIL SOLDER MELTS AND FLOWS AND STRAIN RELIEF TUBING CONFORMS TO CABLE.
4. CABLE ACCOMMODATION: THIS CONTACT WILL ACCOMMODATE CABLES WITH THESE DIMENSIONS.

PREPARATION OF INNER TRIAXIAL CABLE

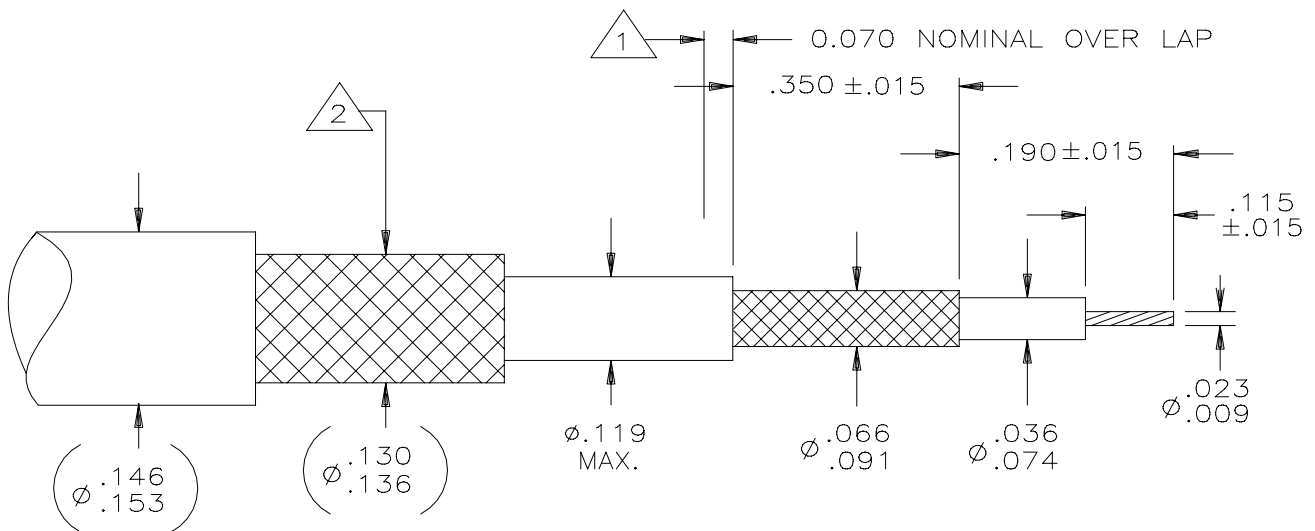

CABLE PREPARATION FOR
STRAIGHT SHIELD

1 AFTER TERMINATION THE CABLE SUPPORT TUBING WILL OVERLAP THE INNER JACKET BY 0.070 NOMINAL.

2 OUTER BRAID IS TERMINATED BY OTHER MEANS

**If this document is printed it becomes uncontrolled.
Check with the web for latest revision.**

DOCUMENT NUMBER: D-602-0140-C8898	
CAD NAME: T29713C.DWG	SHEET 3 of 5

SPECIFICATION CONTROL DRAWING

CONTACT ENGAGEMENT AND SEPARATION FORCES (INNER SOCKET CONTACT ONLY): THE ENGAGEMENT DEPTH SHALL BE AS ENCOUNTERED IN NORMAL SERVICE. THE TEST PINS SHALL BE IN ACCORDANCE WITH MS3197 EXCEPT THE DIAMETERS SHALL BE AS SPECIFIED IN THE FOLLOWING, AND SURFACE ROUGHNESS SHALL NOT EXCEED 3 MICROINCHES. PROVISIONS FOR CLEARANCE HOLE SHALL BE PROVIDED.

TABLE III

TEST PIN DIAMETER (INCH)	MINIMUM SEPARATION FORCE (OUNCES)		MAXIMUM ENGAGEMENT FORCE (OUNCES)	
	INITIAL	AFTER CONDITIONING	INITIAL	AFTER CONDITIONING
.0155 $\begin{matrix} +.0002 \\ -.0000 \end{matrix}$	N/A	N/A	12.0	14.0
.0145 $\begin{matrix} +.0000 \\ -.0002 \end{matrix}$	0.5	0.4	N/A	N/A

DIELECTRIC WITHSTANDING VOLTAGE (APPLIED BETWEEN INNER AND OUTER CONTACT):
TEST VOLTAGE:

AT SEA LEVEL: 800 VAC. RMS.
AT 50,000 FEET: 250 VAC. RMS.

CONTACT RESISTANCE: SEE TABLE IV.

TABLE IV. CONTACT RESISTANCE

TEST CABLE	MAXIMUM VOLTAGE DROP (MILLIVOLTS)						TEST CURRENT (AMPS)	
	$25^{\circ} \begin{matrix} +3^{\circ} \\ -0^{\circ} \end{matrix} C$		$25^{\circ} \begin{matrix} +3^{\circ} \\ -0^{\circ} \end{matrix} C$ <u>3/</u>		$125^{\circ} \begin{matrix} +3^{\circ} \\ -0^{\circ} \end{matrix} C$			
	CONTACT		CONTACT		CONTACT		CONTACT	
	INNER	OUTER	INNER	OUTER	INNER	OUTER	INNER	OUTER
RAYCHEM 10598-30-9X	60	54	72	65	90	81	1.0	7.5

3/ AFTER CONDITIONING.

**If this document is printed it becomes uncontrolled.
Check with the web for latest revision.**

SPECIFICATION CONTROL DRAWING

LOW SIGNAL LEVEL CONTACT RESISTANCE (INNER CONTACT ONLY): SEE TABLE V.
TENSILE STRENGTH (INNER AND OUTER CONTACT SOLDER JOINT): SEE TABLE V.

TABLE V. LOW SIGNAL LEVEL CONTACT RESISTANCE
(INNER CONTACT ONLY) AND TENSILE STRENGTH

TEST CABLE	MAXIMUM CONTACT RESISTANCE (MILLIOHMS)		MINIMUM TENSILE STRENGTH (POUNDS)	
	INITIAL	AFTER CONDITIONING	INNER CONTACT	OUTER CONTACT
RAYCHEM 10598-30-9X	66	80	3.5	20.0

MATERIAL:	CONTACT BODY	BERYLLIUM COPPER, ALLOY 173, CONDITION H PER ASTM B196
	INNER CONTACT	BERYLLIUM COPPER, ALLOY 173, CONDITION H PER ASTM B196
	PLATING (CONTACT BODY AND INNER CONTACT)	GOLD PLATE PER MIL-G-45204 TYPE II, GRADE C 50 MICROINCHES MINIMUM OVER NICKEL PER QQ-N-290A 50 MICROINCHES MINIMUM OVER COPPER STRIKE - 40 MICROINCHES MAXIMUM
	SOLDER	Sn63 PER QQ-S-571
	FLUX	TYPE RMA PER QQ-S-571
	SHRINK TUBING	HEAT-SHRINKABLE, RADIATION-CROSSLINKED POLYVINYLIDENE FLUORIDE
	DIELECTRIC	ETFE FLUOROPOLYMER PER ASTM D3159

SHIPPING FIGURE 1 INDICATES THE ONE-PIECE ASSEMBLY. TERMINATION INSTRUCTIONS ARE TO BE SHIPPED WITH THE UNIT PACKAGE.

**If this document is printed it becomes uncontrolled.
Check with the web for latest revision.**