

RFFM8550

4.9GHz to 5.85GHz 802.11a/n/ac WiFi
Switch + LNA Module

The RFFM8550 provides a complete integrated switch + LNA solution in a single Front End Module (FEM) for WiFi 802.11a/n/ac systems. The ultra-small form factor and integrated matching greatly reduces the number of external components and layout area in the customer applications. This simplifies the total front end solution by reducing the bill of materials, system footprint, and manufacturing cost. The RFFM8550 integrates a Single Pole Two Throw (SP2T) Transmit/Receive (T/R) Switch and a 5.0GHz Low Noise Amplifier (LNA) with bypass mode. The device is provided in a 1.5mm x 1.5mm x 0.40mm 8-pin DFN package.



Package: DFN, 8-pin,
1.5mm x 1.5mm x 0.40mm

Features

- SP2T T/R Switch
- LNA with Bypass Mode
- Input and Output Matched to 50Ω
- Wide Voltage Supply Range
- Supports WiFi chipsets with Integrated Power Amplifier (iPA)
- Low Profile Package for Module Designs

Applications

- Cellular Handsets
- Mobile Devices
- Tablets
- Consumer Electronics
- Gaming
- Netbooks/Notebooks
- TV/Monitors/Video

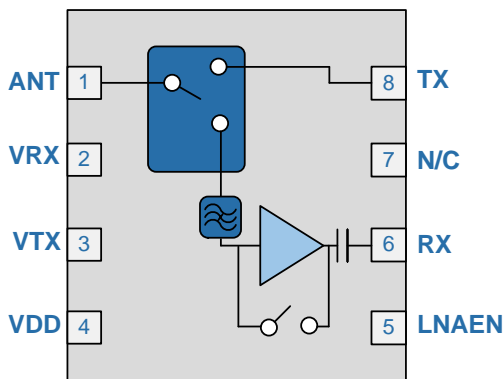

Functional Block Diagram

Ordering Information

RFFM8550SB	Standard 5-piece sample bag
RFFM8550SQ	Standard 25-piece sample bag
RFFM8550SR	Standard 100-piece reel
RFFM8550TR7	Standard 2500-piece reel
RFFM8550PCK-410	Fully assembled evaluation board w/ 5-piece bag

Absolute Maximum Ratings

Parameter	Rating	Unit
DC Supply Voltage (No RF Applied)	-0.5 to 6	V
DC Supply Current	100	mA
Operating Case Temperature	-40 to +85	°C
Storage Temperature	-40 to +150	°C
Maximum TX Input Power for 11b/g/n/ac (No Damage)	+30	dBm
Maximum RX Input Power (No Damage)	+12	dBm
Bypass Mode Maximum RX input power (No damage)	+25	dBm
Moisture Sensitivity	MSL2	



Caution! ESD sensitive device.



RFMD Green: RoHS status based on EU Directive 2011/65/EU (at time of this document revision), halogen free per IEC 61249-2-21, < 1000ppm each of antimony trioxide in polymeric materials and red phosphorus as a flame retardant, and <2% antimony in solder.

Exceeding any one or a combination of the Absolute Maximum Rating conditions may cause permanent damage to the device. Extended application of Absolute Maximum Rating conditions to the device may reduce device reliability. Specified typical performance or functional operation of the device under Absolute Maximum Rating conditions is not implied.

Nominal Operating Parameters

Parameter	Specification			Unit	Condition
	Min	Typ	Max		
Compliance:					4.9GHz to 5.85GHz Only
Operating Frequency	5.18		5.825	GHz	
Extended Frequency	4.9		5.925	GHz	
Operating Temperature	-40	25	85	°C	
Power Supply V_{DD}	3.0	3.6	5.0	V	
Control Voltage-high	2.8	3.1	V_{CC}	V	VTX, VRX, and LNA_EN Should not exceed V_{CC} voltage
Control Voltage-low		0	0.24	V	
Transmit (TX-ANT)					$V_{DD} = 3.6V$, unless otherwise noted
Insertion Loss		0.6	1.2	dB	$T = 25^{\circ}C$, $V_{DD} = 3.6V$
TX Port Return Loss	12	25		dB	
ANT Port Return Loss	12	25		dB	
Input P1dB	27	30		dBm	$T = 25^{\circ}C$, $V_{DD} = 3.6V$
ANT-RX Isolation	28	35		dB	TX Mode-TX enabled and maximum power
Receive (ANT-RX)-LNA On					$V_{DD} = 3.6V$, unless otherwise noted
Gain	9	12	14	dB	$T = 25^{\circ}C$, $V_{DD} = 3.6V$
Gain flatness over any 80MHz BW	-0.25		+0.25	dB	
Gain flatness across band	-1		+1	dB	$T = 25^{\circ}C$, $V_{DD} = 3.6V$
Noise Figure-Nominal		2.5	3	dB	

Parameter	Specification			Unit	Condition
	Min	Typ	Max		
Receive (ANT-RX)-LNA On (continued)					V_{DD} = 3.6V, unless otherwise noted
Rx Port Return Loss	8	12		dB	
ANT Port Return Loss	8	10		dB	
Nominal Input P1dB	-6	-3		dBm	T = 25°C, V _{DD} = 3.6V
Current Consumption	6	10	16	mA	
LNAEN Control Current		140	250	μA	
LNA Turn On Time		400	600	nS	
Receive (ANT-RX)-Bypass Mode					V_{DD} = 3.6V, unless otherwise noted
Insertion Loss	5	7	12	dB	T = 25°C, V _{DD} = 3.6V
RX Port Return Loss	8	12		dB	
ANT Port Return Loss	8	15		dB	
Input P1dB	15	20		dBm	T = 25°C, V _{DD} = 3.6V
General Specifications					V_{DD} = 3.6V, unless otherwise noted
Control Line Impedance - VTX		40		MΩ	
Control Line Impedance - LNAEN		70		kΩ	
Control Line Impedance - VRX		40		MΩ	
V _{DD} Leakage Current		0.2	10	μA	
Switch Control Current – High - Each Line		2	10	μA	
Switch Control Current – Low - Each Line		0.1	1	μA	T = 25°C, V _{DD} = 3.6V
Switching Speed		100	500	ns	
ESD – Human Body Model		1000		V	
ESD – Charge Device Model		1000		V	

Switch Control Logic Truth Table

Operating Mode	VTX	LNAEN	VRX
Standby	Low	Low	Low
802.11a/n/ac TX Mode	High	Low	Low
802.11a/n/ac RX Gain	Low	High	High
802.11a/n/ac RX Bypass	Low	Low	High

Note: High = 2.8 to V_{CC}. Low = 0V to 0.2V.

Timing Diagram

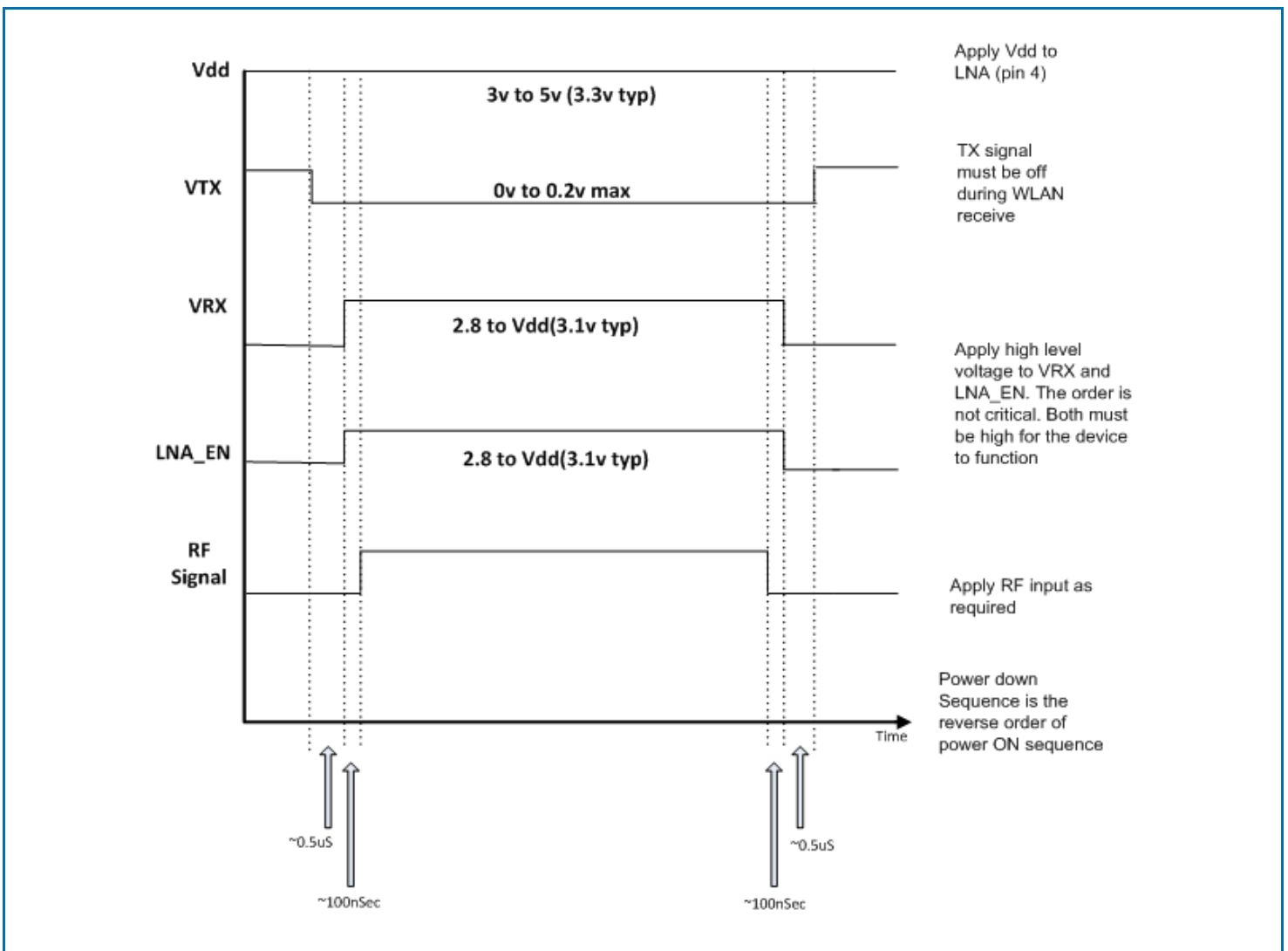

Evaluation Board Schematic

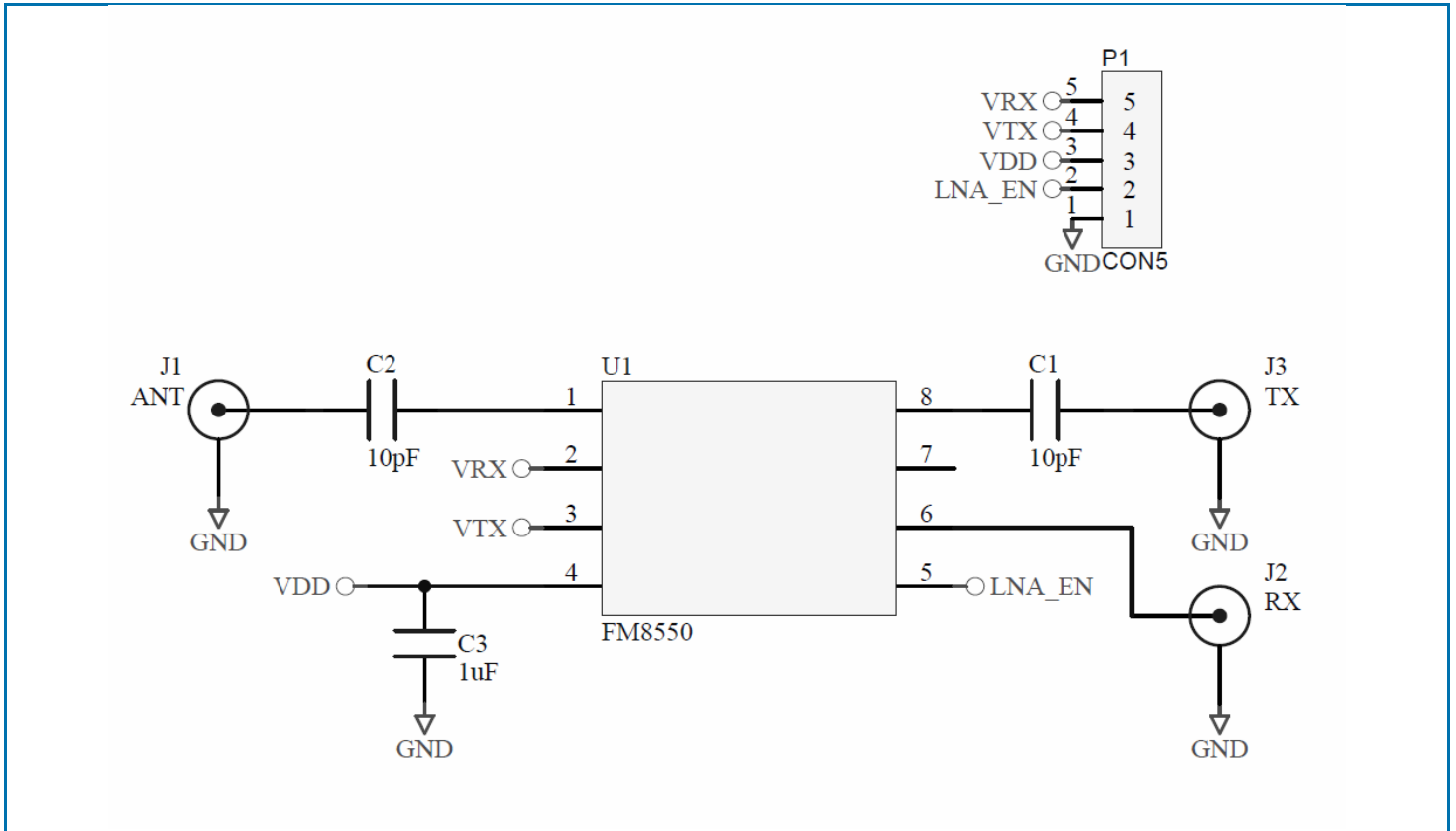

Pin Out

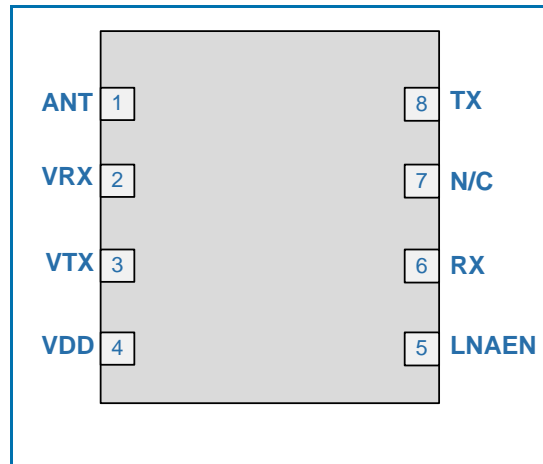

Package Drawing

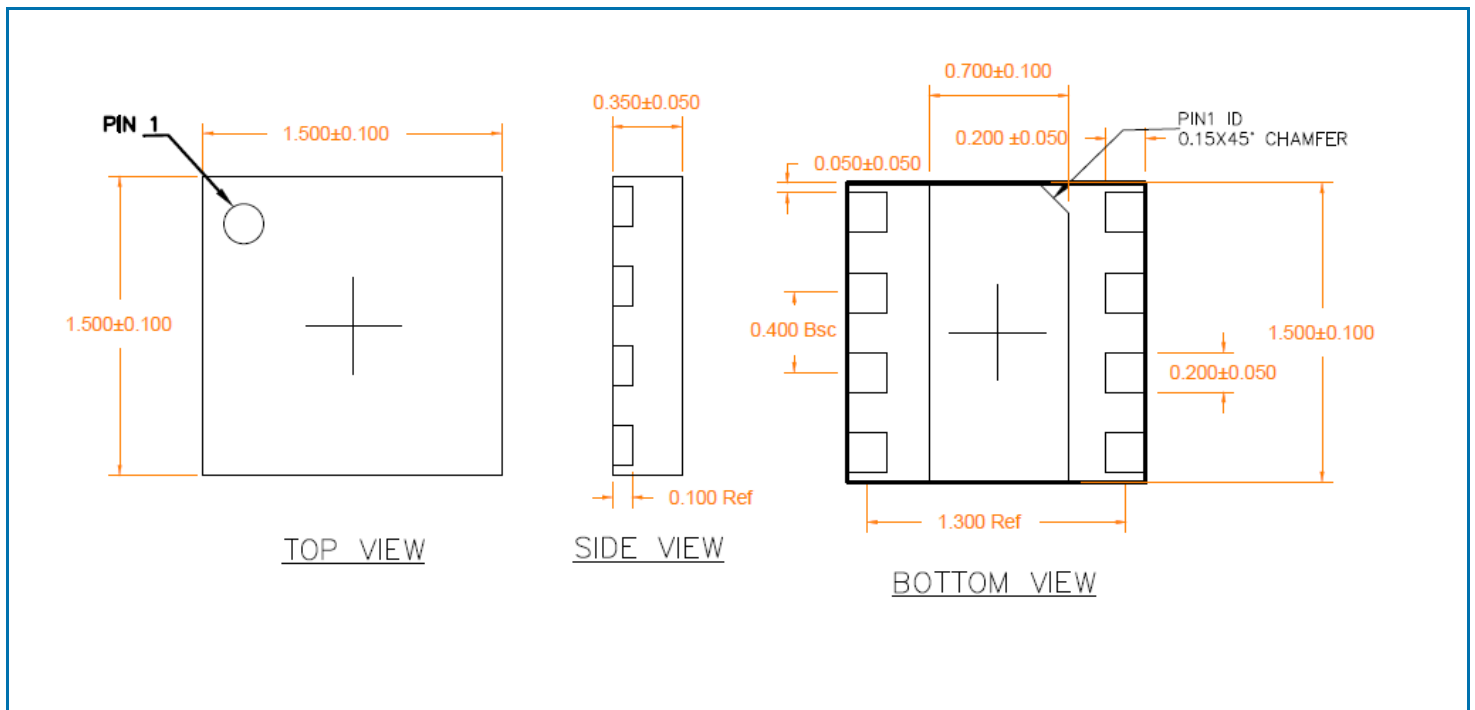

PCB Patterns

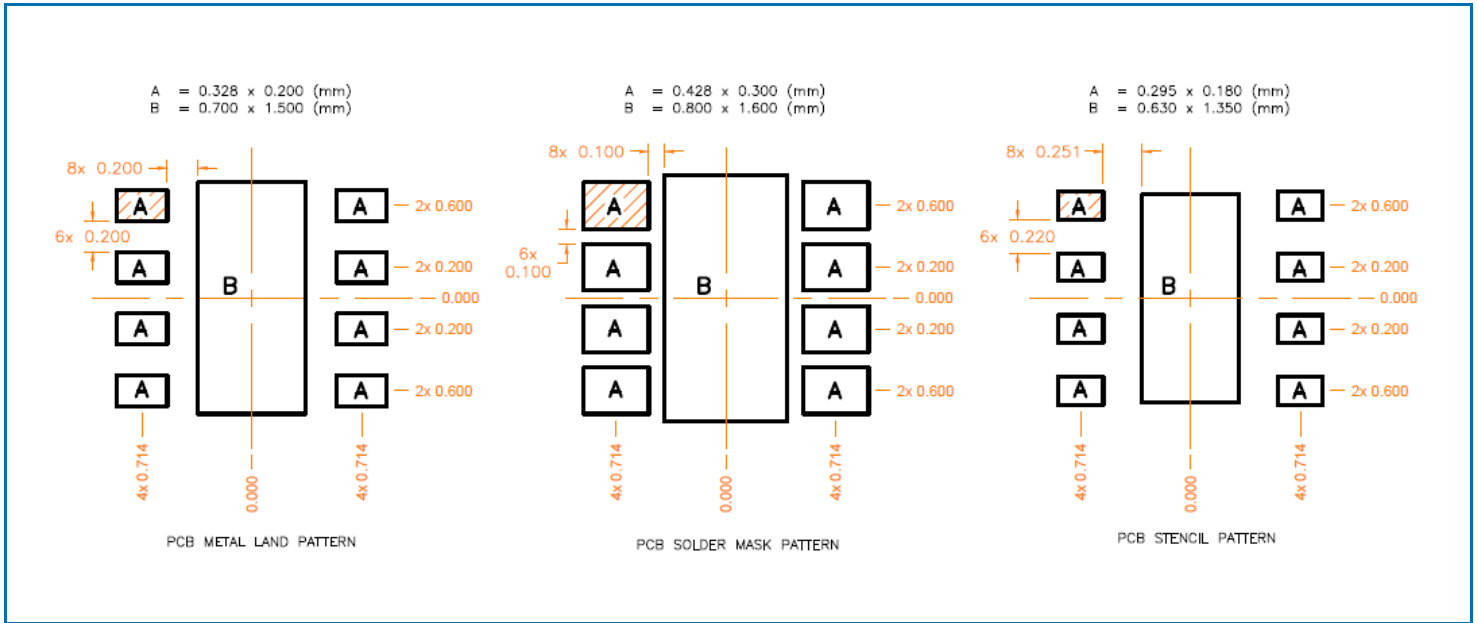

Note: Shaded area represents Pin 1.

Pin Names and Descriptions

Pin	Name	Description
1	ANT	RF bidirectional antenna port matched to 50Ω. An external DC block is required.
2	VRX	Receive switch control pin. See switch truth table for proper voltage level.
3	VTX	Control voltage for the TX switch. See truth table for proper voltage level.
4	VDD	Supply voltage for the LNA. See applications schematic for bypassing components.
5	LNAEN	Control voltage for the LNA. When this pin is set to a LOW logic state, the bypass mode is enabled.
6	RX	RF output port for the 802.11a/n/ac LNA. This port is matched to 50Ω and DC blocked internally
7	N/C	This pin is not connected internally and can be left floating or connected to ground.
8	TX	RF input port for the TX throw of the T/R switch. An external DC block is required
Pkg Base	GND	Ground connection. The backside of the package should be connected to the ground plane through a short path, i.e., PCB vias under the device are recommended.