

EVERY DENNISON MARKETING SPECIFICATION

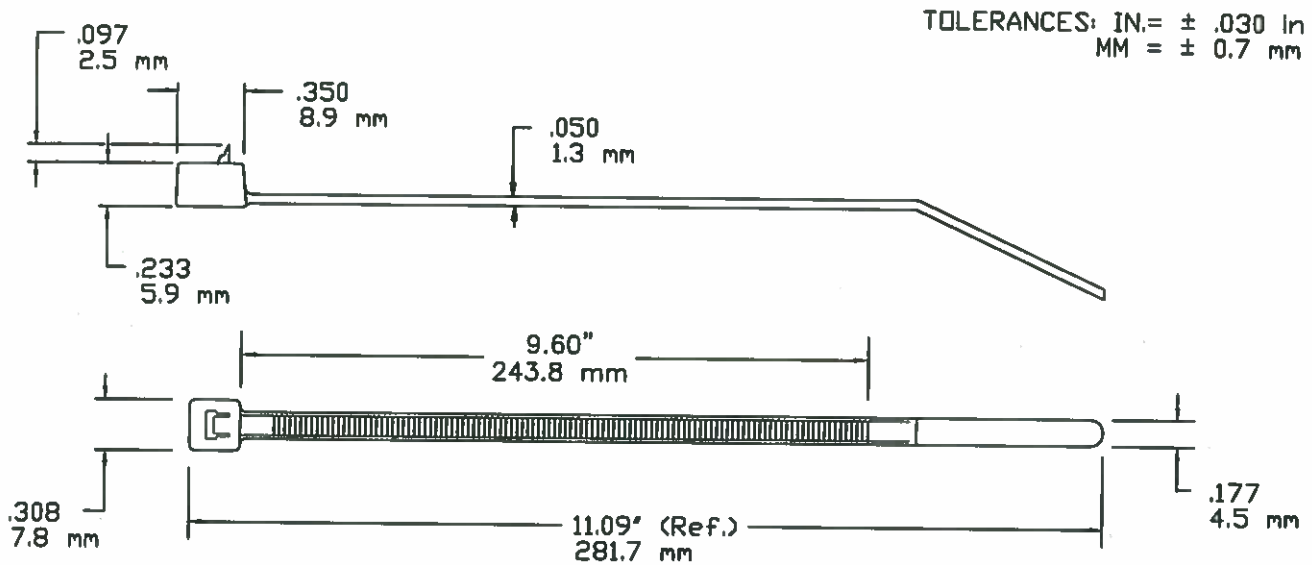

TOLERANCES: IN. = ± .030 in
MM = ± 0.7 mm

NOT TO SCALE

| | |
|-------------------------|---------------------------------|
| LOOP TENSILE STRENGTH: | 50 LBF / 220N MIN. PER AS-23190 |
| OPERATING TEMPERATURE: | -40°F (-40°C) TO 185°F (85°C) |
| MIN. INSTALLATION TEMP: | 32°F (0°C) |
| MATERIAL: | NYLON 6/6 |
| WEIGHT: | .06878 oz. / 2.02 grams |
| BUNDLE DIAMETER: | Ø0.063"/1.59mm TO Ø3.0"/76.2mm |
| PACKAGED IN: | 1000/BAG, 5000/CASE |

NOTE: THESE CABLE TIES ARE PLENUM RATED AND HAVE A FLAMMABILITY RATING OF V2.



FASTENER DIVISION
FITCHBURG, MA 01420 U.S.A.
TEL. 1-800-225-5913
MA. 978-353-8157



E57800
TYPE11

DESCRIPTION:

11" / 280mm CABLE TIE, RELEASABLE
NATURAL

APPROVAL:

J. Boyle 9-18-2015

STOCK NO.

10367-0

REV

F