

THIS DRAWING IS UNPUBLISHED. RELEASED FOR PUBLICATION
 © COPYRIGHT - By - ALL RIGHTS RESERVED.

REVISIONS					
P	LTR	DESCRIPTION	DATE	DWN	APVD
	AD4	PN 1-163087-0 OBSOLETE	18MAY2017	TJ	NG

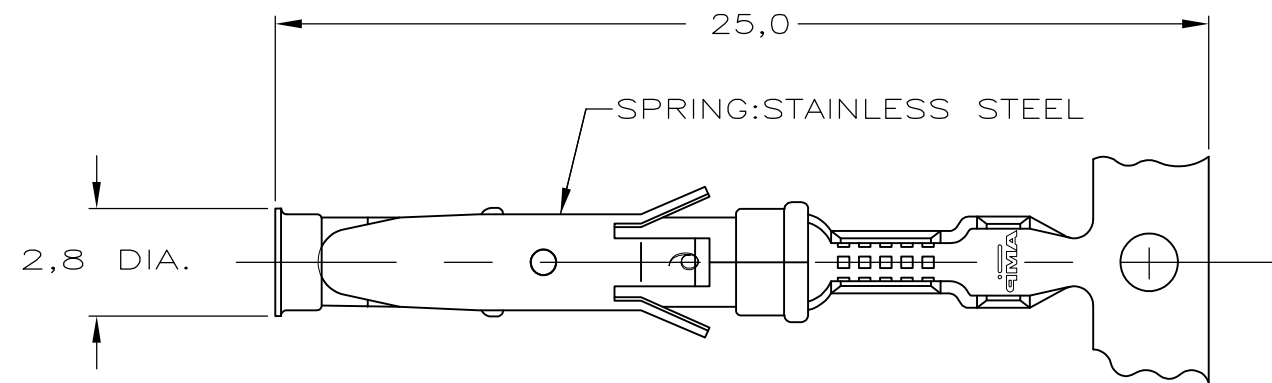

STRIP

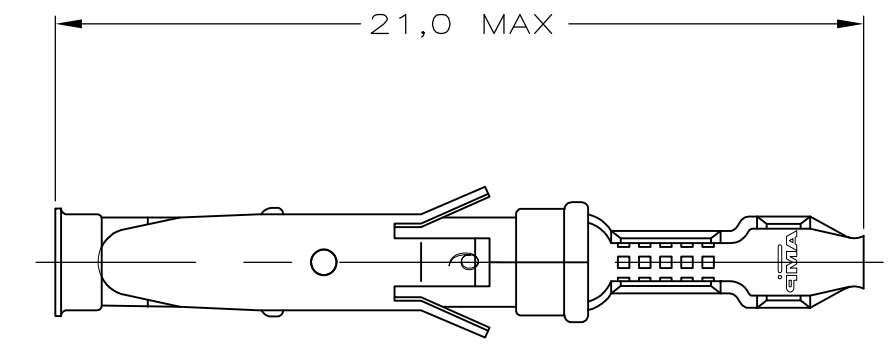

LOOSE-PIECE

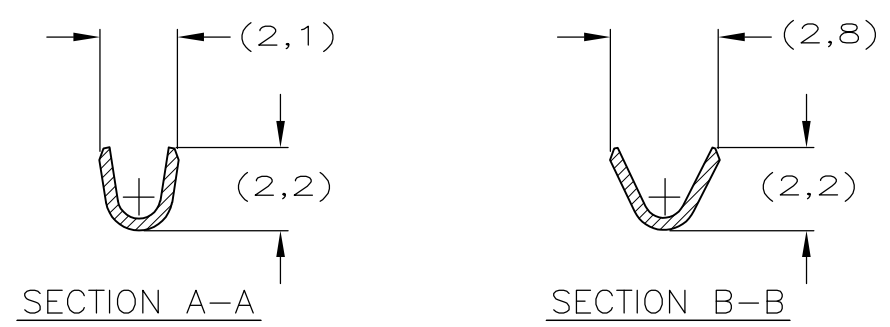
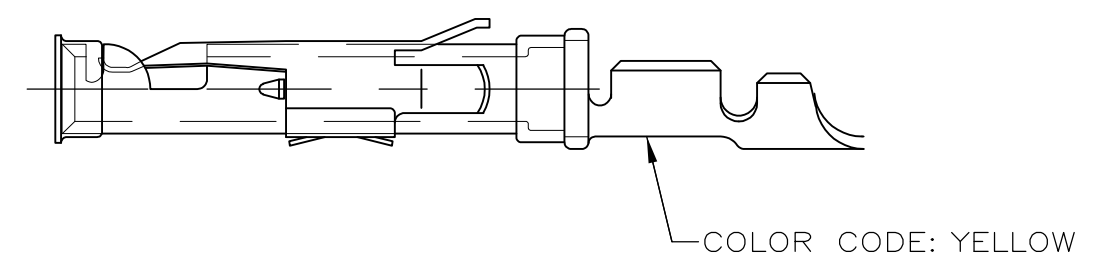
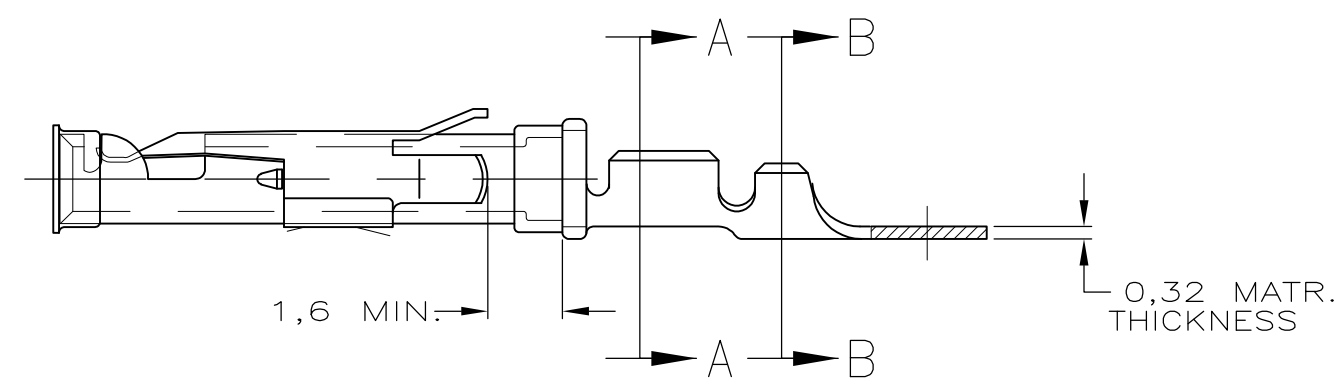

WIRE RANGE : 0,2-0,50 mm² (24-20 AWG)
 INSUL. RANGE : 1,1 -1,8 mm (.080-.100)

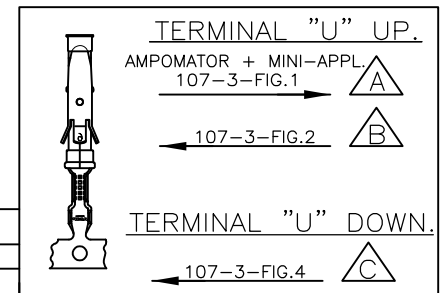

REVISION	DESCRIPTION	PART NUMBER	DIRECTION OF REEL	LOOSE-PIECE	MATERIAL	PLATING
28		1-163087-5	A	61-163088-4	BRASS	SILVER
20		1-163087-4	A	61-163088-4	BRASS	EL.TIN
31		1-163087-3	A	61-163088-3	BRASS	BR.TIN/LEAD
21		5-163087-3	C		BRASS	ECON.GOLD
22		5-163087-2	C		BRASS	SEL.GOLD
20		5-163087-1	C		BRASS	EL.TIN
23		1-163087-2	B	61-163088-1	BRASS	GOLD
21		1-163087-1	A		BRASS	ECON.GOLD
21		1-163087-0	B	1-163088-0	BRASS	ECON.GOLD
20		163087-9	A		BRASS	EL.TIN
22		163087-8	A		BRASS	SEL.GOLD
22		163087-2	B	163088-1	BRASS	SEL.GOLD
20		163087-1	B	163088-1	BRASS	EL.TIN

- NOTES :
- 1 UL RECOGNIZED UNDER E28476 VOL VI SEC I
 - 2 FOR CRIMP DETAILS SEE SPEC. 114-19000
 - 3 MEETS PRODUCT SPECIFICATION 108-10042
 - 4 SPECIAL REEL WITH 200PCS FOR REEL-FED HAND-TOOL
 - 5 OBSOLETE PARTS: OBSOLETE CIS STREAMLINING PER D.RENAUD/D.SINISI
 - 6 OBSOLETE
 - 7 OMISSION OF 6 CONTACTS MAX PER REEL OF 5000PCS
 - 31 LUBRICATED

NOTES	MATERIAL	THICKNESS	AREA
20	TIN	2,0 μm	ALL OVER
21	NICKEL GOLD TIN	0,8 μm	ALL OVER CONTACT AREA BARREL
22	NICKEL GOLD GOLD	0,8 μm	ALL OVER CONTACT AREA ALL OVER
23	NICKEL GOLD GOLD	1,2 μm	ALL OVER CONTACT AREA ALL OVER
27	NICKEL SILVER TIN	2,5 μm	ALL OVER CONTACT AREA BARREL
28	SILVER NICKEL	1,5-2,5 μm	ALL OVER
29	SILVER	0,76 μm	ALL OVER
30	NICKEL BR TIN	1,27 μm	ALL OVER
		1,27 μm	ALL OVER

THIS DRAWING IS A CONTROLLED DOCUMENT.

DIMENSIONS:	TOLERANCES UNLESS OTHERWISE SPECIFIED:
mm	0 PLC ± -
	1 PLC ± -
	2 PLC ± -
	3 PLC ± -
	4 PLC ± -
	ANGLES ± -
MATERIAL	FINISH
REFER TABLE	REFER TABLE

DWN	21JULY2015	M THAJUDEEN
CHK	21JULY2015	GANI NIMBENNAPPA
APVD	21JULY2015	PRASHANTH S
PRODUCT SPEC	108-10042	
APPLICATION SPEC	114-19000	
WEIGHT	0.539g	
CUSTOMER DRAWING		

STE TE Connectivity			
TYPE III+, SIZE 16, SOCKET ASS'Y, 24-20 AWG, 1.1-1.8mm DIA INSULATION			
SIZE	CAGE CODE	DRAWING NO	RESTRICTED TO
A3	00779	C-163087	-
SCALE	SHEET	REV	
-	1 OF 1	AD4	