

Features

- 1-dB Attenuation Steps to 15 dB
- High Accuracy
- Low Intermodulation Product: +50 dBm IP3
- Low DC Power Consumption: 50 μ W
- Tape and Reel Packaging Available
- Temperature Stability +/-0.15 dB: -40°C to +85°C
- Lead-Free SOIC-16 Package
- 100% Matte Tin Plating over Copper
- Halogen-Free “Green” Mold Compound
- 260°C Re-flow Compatible
- RoHS* Compliant Version of AT-210

Description

M/A-COM's MAATSS0015 is a 4-bit, 1-dB step GaAs MMIC digital attenuator in a lead-free SOIC 16-lead surface mount plastic package. The MAATSS0015 is ideally suited for use where high accuracy, fast switching, very low power consumption and low intermodulation products are required. Typical applications include radio, cellular, and wireless LANs, GPS equipment and other gain/level control circuits.

The MAATSS0015 is fabricated with a monolithic GaAs MMIC using a mature 1-micron process. The process features full chip passivation for increased performance and reliability.

Ordering Information¹

Part Number	Package
MAATSS0015	SOIC 16-Lead Plastic Package
MAATSS0015TR	Tape & Reel

1. Reference Application Note M513 for reel size information.

Functional Schematic

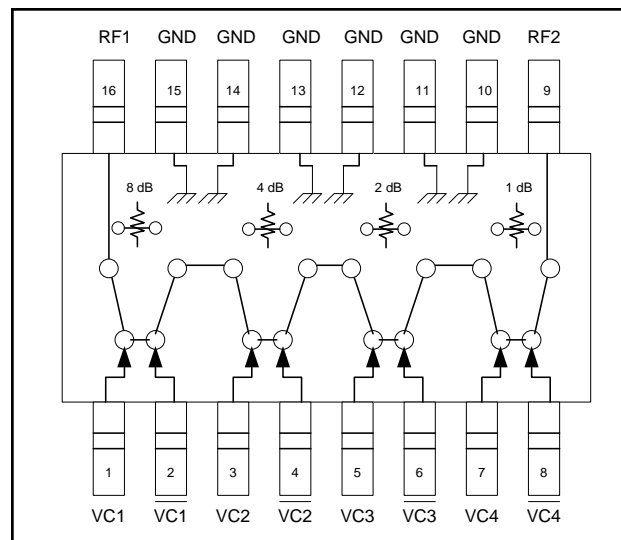

Pin Configuration

Pin No.	Function	Pin No.	Function
1	VC1	9	RF2
2	$\overline{\text{VC1}}$	10	GND
3	VC2	11	GND
4	$\overline{\text{VC2}}$	12	GND
5	VC3	13	GND
6	$\overline{\text{VC3}}$	14	GND
7	VC4	15	GND
8	$\overline{\text{VC4}}$	16	RF1

Absolute Maximum Ratings^{2,3}

Parameter	Absolute Maximum
Input Power: 50 MHz 500-2000 MHz	+27 dBm +34 dBm
Control Voltage	-8.5 V \leq V _C \leq 5V
Operating Temperature	-40°C to +85°C
Storage Temperature	-65°C to +150°C

2. Exceeding any one or combination of these limits may cause permanent damage to this device.
3. M/A-COM does not recommend sustained operation near these survivability limits.

* Restrictions on Hazardous Substances, European Union Directive 2002/95/EC.

ADVANCED: Data Sheets contain information regarding a product M/A-COM Technology Solutions is considering for development. Performance is based on target specifications, simulated results, and/or prototype measurements. Commitment to develop is not guaranteed.
PRELIMINARY: Data Sheets contain information regarding a product M/A-COM Technology Solutions has under development. Performance is based on engineering tests. Specifications are typical. Mechanical outline has been fixed. Engineering samples and/or test data may be available. Commitment to produce in volume is not guaranteed.

• **North America** Tel: 800.366.2266 / Fax: 978.366.2266
 • **Europe** Tel: 44.1908.574.200 / Fax: 44.1908.574.300
 • **Asia/Pacific** Tel: 81.44.844.8296 / Fax: 81.44.844.8298
 Visit www.macomtech.com for additional data sheets and product information.

M/A-COM Technology Solutions Inc. and its affiliates reserve the right to make changes to the product(s) or information contained herein without notice.

Electrical Specifications: $T_A = 25^\circ\text{C}$, $V_C = 0\text{ V} / -5\text{ V}$, $Z_0 = 50\ \Omega$

Parameter	Test Conditions	Frequency	Units	Min.	Typ.	Max.
Insertion Loss (Reference state)		DC - 0.1 GHz	dB	—	0.9	—
		DC - 0.5 GHz	dB	—	1.3	1.5
		DC - 1.0 GHz	dB	—	1.5	1.8
		DC - 2.0 GHz	dB	—	2.0	—
Attenuation Accuracy ⁴		DC - 1.0 GHz DC - 2.0 GHz		$\pm (0.15\text{ dB} + 3\% \text{ of Atten Setting in dB})\text{ dB}$ $\pm (0.30\text{ dB} + 3\% \text{ of Atten Setting in dB})\text{ dB}$		
VSWR			Ratio	—	1.4	—
Trise, Tfall	10% to 90% RF, 90% to 10% RF	—	nS	—	10	—
Ton, Toff	50% Control to 90% RF, 50% Control to 10% RF	—	nS	—	15	—
Transients	In-Band	—	mV	—	18	—
1 dB Compression	Input Power Input Power	0.05 GHz	dBm	—	22	—
		0.5 - 2.0 GHz	dBm	—	28	—
IP ₂	Measured Relative to Input Power (For two-tone input power up to +5 dBm)	0.05 GHz	dBm	—	49	—
		0.5 - 2.0 GHz	dBm	—	72	—
IP ₃	Measured Relative to Input Power (For two-tone input power up to +5 dBm)	0.05 GHz	dBm	—	45	—
		0.5 - 2.0 GHz	dBm	—	50	—
Control Current	$ V_C = 5\text{ V}$		μA	—	10	20

4. Attenuation accuracy specifications apply with negative bias control and low inductance grounding.

Lead-Free SOIC-16[†]

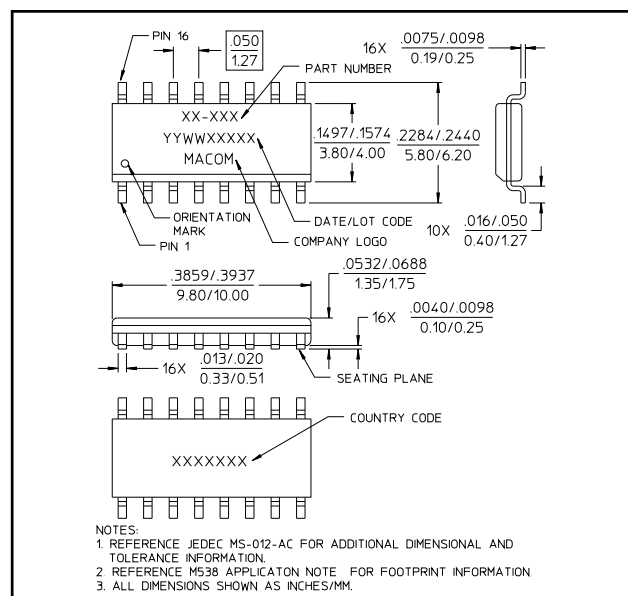

[†] Reference Application Note M538 for lead-free solder reflow recommendations.

Meets JEDEC moisture sensitivity level 1 requirements

Truth Table ⁵

Control Inputs								Attenuation (dB)
\overline{VC} 4	VC 4	\overline{VC} 3	VC 3	\overline{VC} 2	VC 2	\overline{VC} 1	VC 1	
1	0	1	0	1	0	1	0	Reference state
0	1	1	0	1	0	1	0	1 dB
1	0	0	1	1	0	1	0	2 dB
1	0	1	0	0	1	1	0	4 dB
1	0	1	0	1	0	0	1	8 dB
0	1	0	1	0	1	0	1	15 dB

5. 0 = -0.2 V to 0 V, 1 = -8 V to -5 V.

Typical Performance Curves

Insertion Loss

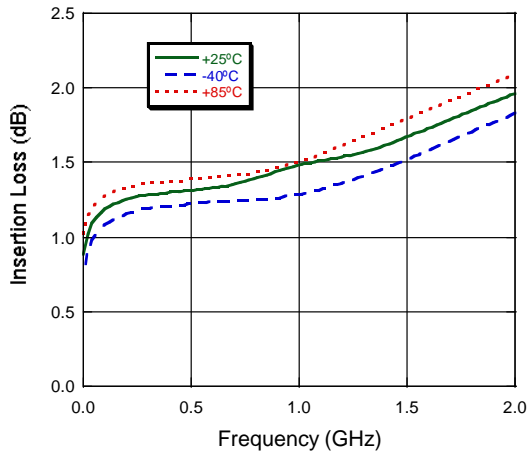

Attenuation Accuracy

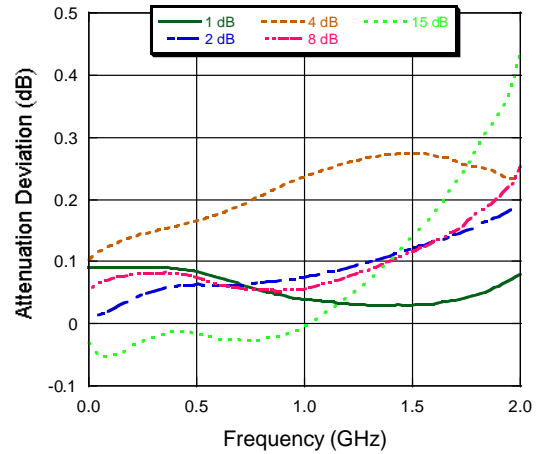

VSWR

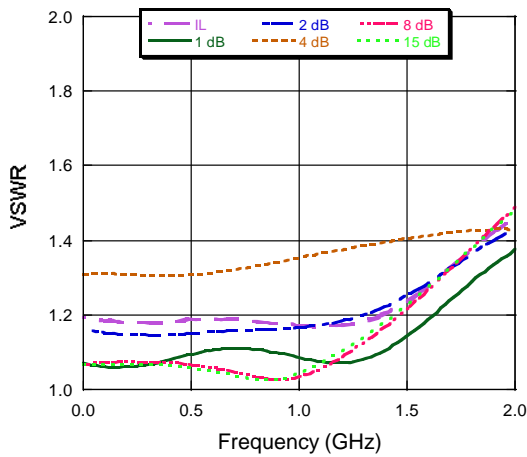

Attenuation

