

CIPOS™ Tiny IPM 600V/10A

IM393-M6E

Description

IM393-M6E is a 10A, 600V Integrated Power Hybrid IC with Open Emitter pins for advanced Appliance Motor Drives applications such as energy efficient fan and pumps. Infineon's technology offers an extremely compact, high performance AC motor-driver in a single isolated package to simplify design.

This advanced IPM is a combination of Infineon's newest low VCE(on) Trench IGBT technology optimized for best trade-off between conduction and switching losses and the industry benchmark 3 phase high voltage, high speed driver (3.3V compatible) in a fully isolated thermally enhanced package. A built-in high precision temperature monitor and over-current protection feature, along with the short-circuit rated IGBTs and integrated under-voltage lockout function, deliver high level of protection and fail-safe operation. Using a dual in line package with full transfer mold structure resolves isolation problems to heatsink.

Features

- Integrated gate drivers and bootstrap function
- Temperature monitor
- Protection shutdown pin
- Low VCE (on) Trench IGBT technology
- Under voltage lockout for all channels
- Matched propagation delay for all channels
- 3.3V Schmitt-triggered input logic
- Cross-conduction prevention logic
- Isolation 2000V_{RMS} min and CTI > 600
- Recognized by UL (File Number E314539)

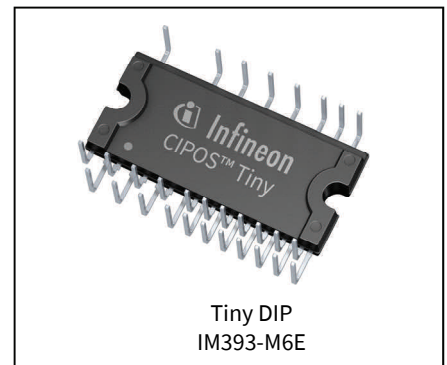

Potential applications

- Washing machines
- Air-conditioners
- Refrigerators
- Fans
- Dishwashers
- Low power motor drives

Product validation

Qualified for industrial applications according to the relevant tests of JEDEC47/20/22.

Table1 Part Ordering Table

Base part number	Package Type	Standard Pack		Orderable Part Number
		Form	Quantity	
IM393-M6E	Tiny DIP	30 Tubes	450	IM393-M6E
IM393-M6E2	Tiny DIP, 3mm lead	30 Tubes	450	IM393-M6E2
IM393-M6E3	Tiny DIP, 3mm lead	30 Tubes	450	IM393-M6E3

Table of Contents

Table of Contents

Description	1
Features	1
Potential Applications	1
Product validation	1
Table of Contents	2
1 Internal Electrical Schematic	3
2 Pin Configuration	4
2.1 Pin Assignment	5
2.2 Pin Descriptions	6
3 Absolute Maximum Rating	8
3.1 Module	8
3.2 Inverter	8
3.3 Control	8
4 Thermal Characteristics	9
5 Recommended Operating Conditions	10
6 Static Parameters	11
6.1 Inverter	11
6.2 Control	11
7 Dynamic Parameters	13
7.1 Inverter	13
7.2 Control	13
8 Thermistor Characteristics	14
9 Mechanical Characteristics and Ratings	15
10 Qualification Information	16
11 Diagrams & Tables	17
11.1 T _c Measurement Point	17
11.2 Input-Output Logic Table	17
11.3 Switching Time Definitions	18
12 Application Notes	19
12.1 Typical Application Schematic	19
12.2 T _J VS T _{TH}	20
12.3 -V _S Immunity	20
13 Package Outline	21
Revision History	23

1 Internal Electrical Schematic

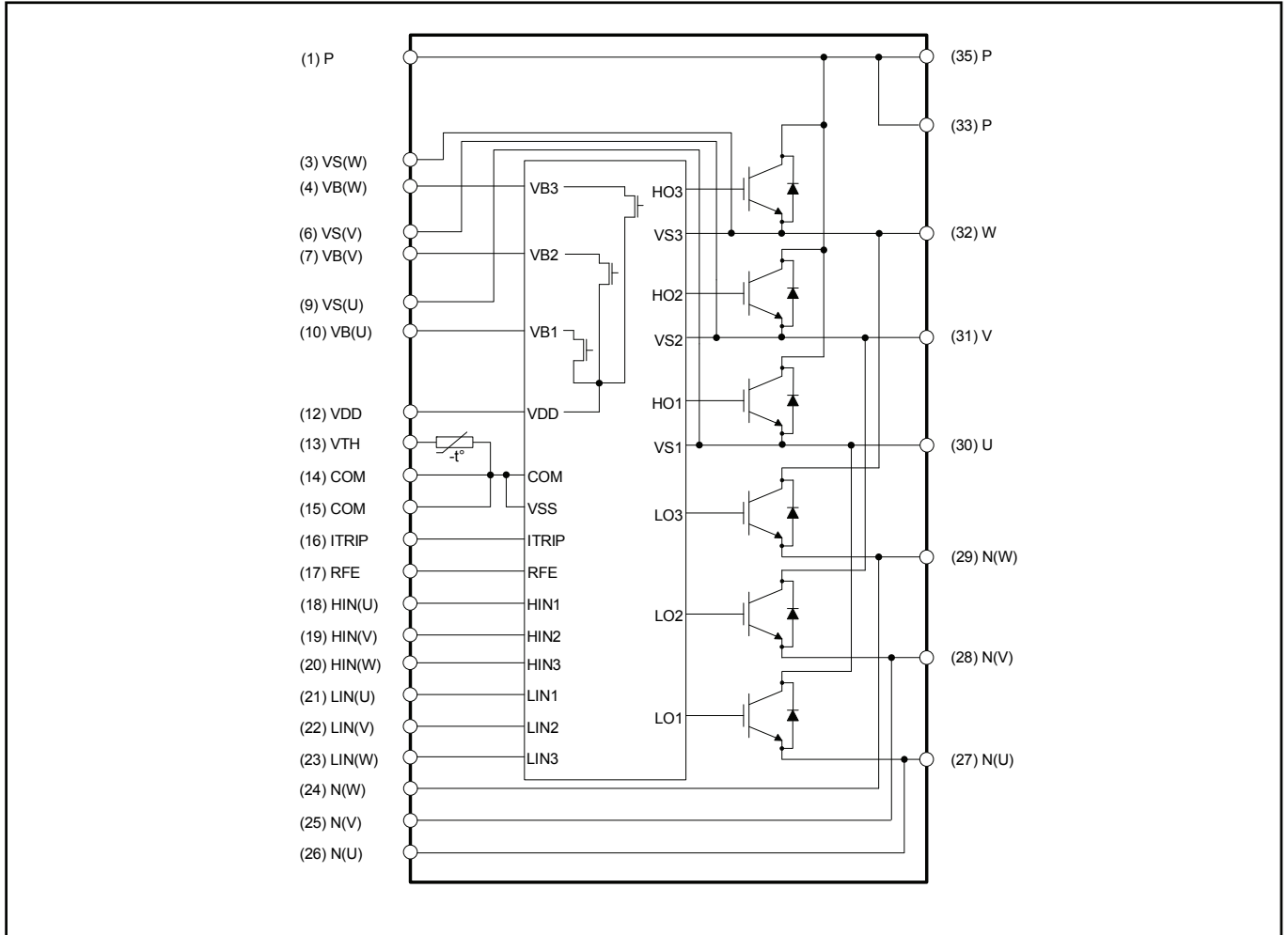

Figure 1 Internal electrical schematic

2 Pin Configuration

2.1 Pin Assignment

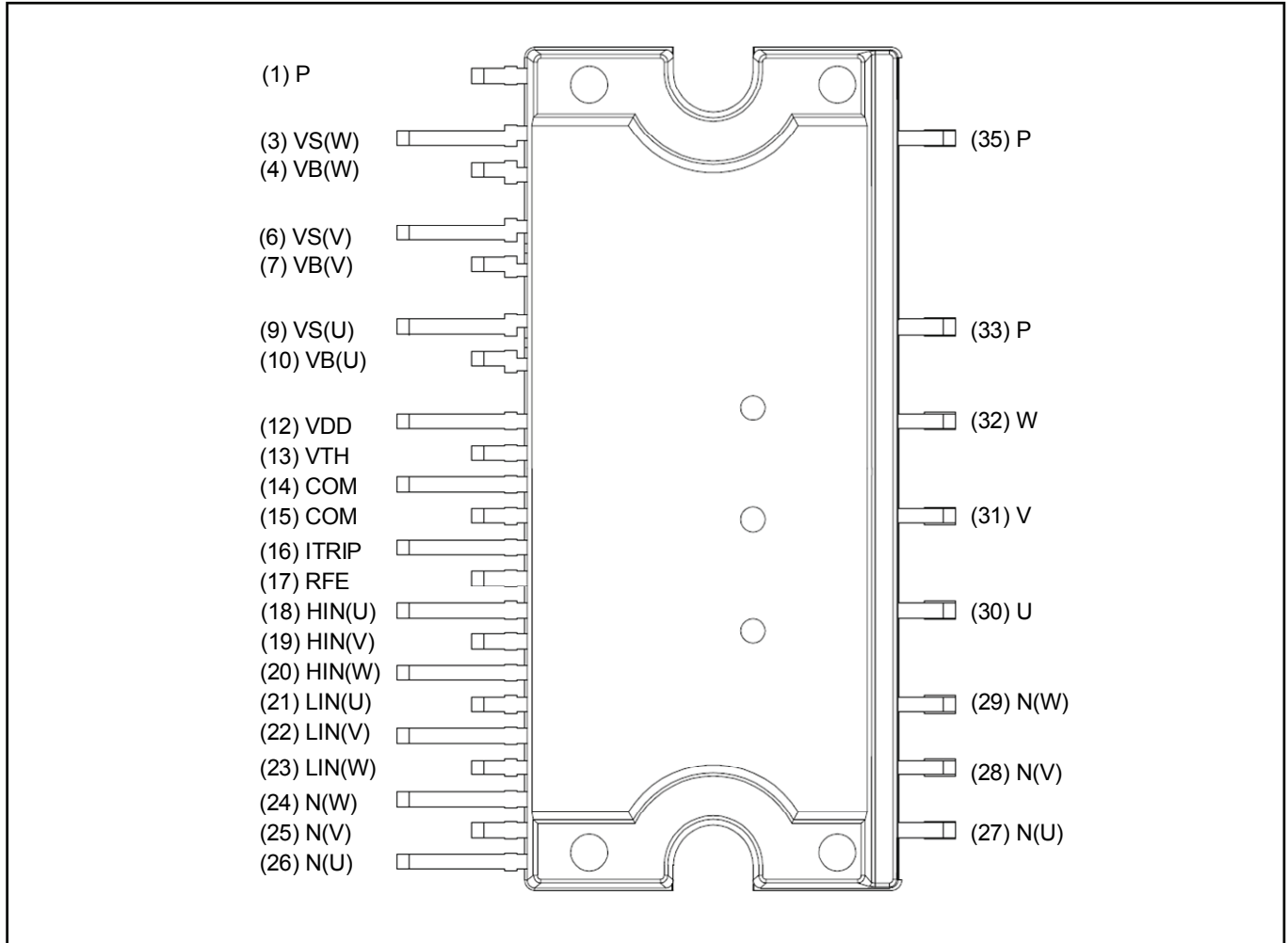

Figure 2 Pin configuration

Pin Configuration

Table 2 Pin Assignment

Pin	Name	Description
1	P	Positive bus input voltage
2	N/A	None
3	VS(W)	W-phase high side floating supply offset voltage
4	VB(W)	W-phase high side floating supply voltage
5	N/A	None
6	VS(V)	V - phase high side floating supply offset voltage
7	VB(V)	V - phase high side floating supply voltage
8	N/A	None
9	VS(U)	U- phase high side floating supply offset voltage
10	VB(U)	U- phase high side floating supply voltage
11	N/A	None
12	VDD	Low side control supply
13	VTH	Temperature monitor
14	COM	Low side control negative supply
15	COM	Low side control negative supply
16	ITRIP	Over current protection input
17	RFE	RCIN / Fault / Enable
18	HIN(U)	U-phase high side gate driver input
19	HIN(V)	V-phase high side gate driver input
20	HIN(W)	W-phase high side gate driver input
21	LIN(U)	U-phase low side gate driver input
22	LIN(V)	V-phase low side gate driver input
23	LIN(W)	W-phase low side gate driver input
24	N(W)	W-phase low side emitter
25	N(V)	V-phase low side emitter
26	N(U)	U-phase low side emitter
27	N(U)	U-phase low side emitter
28	N(V)	V-phase low side emitter
29	N(W)	W-phase low side emitter
30	U	U-phase output
31	V	V-phase output
32	W	W-phase output
33	P	Positive bus input voltage
34	N/A	None
35	P	Positive bus input voltage
36	N/A	None

2.2 Pin Descriptions

HIN(U,V,W) and LIN(U,V,W) (High side and low side control pins)

These pins are positive logic and they are responsible for the control of the integrated IGBT. The Schmitt-trigger input thresholds of them are such to guarantee LSTTL and CMOS compatibility down to 3.3V controller outputs. Pull-down resistor of about 4kΩ is internally provided to pre-bias inputs during supply start-up and an ESD diode is provided for pin protection purposes. Input Schmitt-trigger and noise filter provide beneficial noise rejection to short input pulses.

The noise filter suppresses control pulses which are below the filter time t_{FILIN} . The filter acts according to Figure 4.

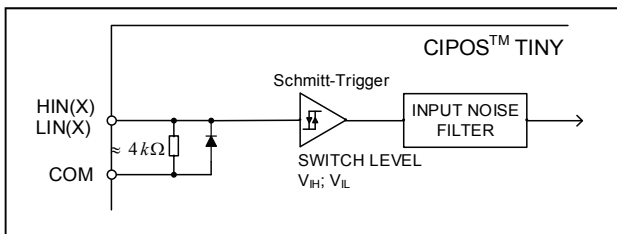

Figure 3 Input pin structure

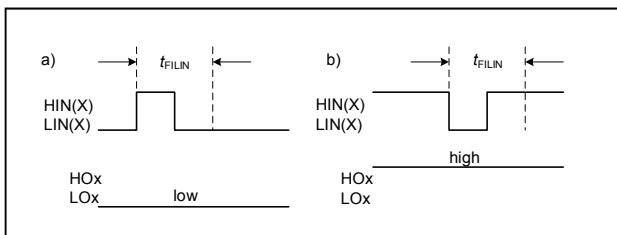

Figure 4 Input filter timing diagram

The integrated gate drive provides additionally a shoot through prevention capability which avoids the simultaneous on-state of the high-side and low-side switch of the same inverter phase. A minimum deadtime insertion of typically 275ns is also provided by driver IC, in order to reduce cross-conduction of the external power switches.

V_{DD}, COM (Low side control supply and reference)

V_{DD} is the control supply and it provides power both to input logic and to output power stage. Input logic is referenced to COM ground.

The under-voltage circuit enables the device to operate at power on when a supply voltage of at least a typical voltage of $V_{DDUV+} = 10.4V$ is present.

The IC shuts down all the gate drivers power outputs, when the V_{DD} supply voltage is below $V_{DDUV-} = 9.4V$. This prevents the external power switches from critically low gate voltage levels during on-state and therefore from excessive power dissipation.

V_{B(U,V,W)} and V_{S(U,V,W)} (High side supplies)

V_B to V_S is the high side supply voltage. The high side circuit can float with respect to COM following the external high side power device emitter voltage.

Due to the low power consumption, the floating driver stage is supplied by integrated bootstrap circuit.

The under-voltage detection operates with a rising supply threshold of typical $V_{BSUV+} = 10.41V$ and a falling threshold of $V_{BSUV-} = 9.4V$.

V_{S(U,V,W)} provide a high robustness against negative voltage in respect of COM. This ensures very stable designs even under rough conditions.

N(U, V, W) (Low side emitters)

The low side emitters are available for current measurements of each phase leg. It is recommended to keep the connection to pin COM as short as possible in order to avoid unnecessary inductive voltage drops.

VTH (Thermistor)

A UL certified NTC is integrated in the module with one terminal of the chip connected to COM and the other to VTH. When pulled up to a rail voltage such as V_{DD} or 3.3V by a resistor, the VTH pin provides an analog voltage signal corresponding to the temperature of the thermistor.

RFE (RCIN / Fault / Enable)

The RFE pin combines 3 functions in one pin: RCIN or RC-network based programmable fault clear timer, fault output and enable input.

The RFE pin is normally connected to an RC network on the PCB per the schematic in Figure 5. Under normal operating conditions, R_{RCIN} pulls the RFE pin to 3.3V, thus enabling all the functions in the IPM. The microcontroller can pull this pin low to disable the IPM functionality. This is the Enable function.

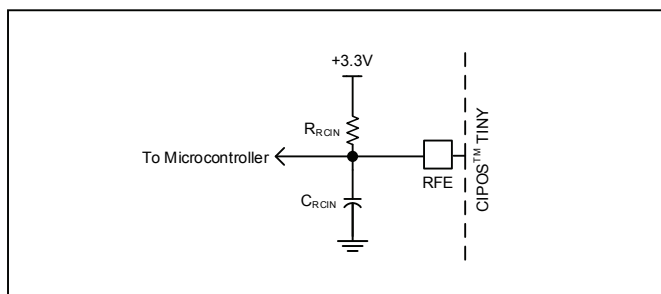

Figure 5 Typical PCB circuit connected to the RFE pin

The Fault function allows the IPM to report a Fault condition to the microcontroller by pulling the RFE pin low in one of two situations. The first is an under-voltage condition on V_{DD} and the second is when the ITRIP pin sees a voltage rising above $V_{IT,TH+}$.

The programmable fault clear timer function provides a means of automatically re-enabling the module operation a preset amount of time ($T_{FLT-CLR}$) after the fault condition has disappeared. Figure 6 shows the RFE-related circuit block diagram inside the IPM.

The length of $T_{FLT-CLR}$ can be determined by using the formula below.

$$V_{RFE}(t) = 3.3V * (1 - e^{-t/RC})$$

$$T_{FLT-CLR} = -R_{RCIN} * C_{RCIN} * \ln(1 - V_{IN,TH+}/3.3V)$$

For example, if R_{RCIN} is 1.2M Ω and C_{RCIN} is 1nF, the $T_{FLT-CLR}$ is about 1.7ms with $V_{IN,TH+}$ of 2.5V. It is also important to note that C_{RCIN} needs to be minimized in order to make sure it is fully discharged in case of over current event.

Since the ITRIP pin has a 350ns input filter, it is appropriate to ensure that C_{RCIN} will be discharged below $V_{IN,TH-}$ by the open-drain MOSFET, after 350ns. Therefore, the max C_{RCIN} can be calculated as:

$$V_{RFE}(t) = 3.3V * e^{-t/RC} < V_{IN,TH-}$$

$$C_{RCIN} < 350ns / (- \ln(V_{IN,TH-} / 3.3V)) * R_{RFE_ON}$$

Consider $V_{IN,TH-}$ of 0.8V and R_{RFE_ON} of 50ohm, C_{RCIN} should be less than 4.9nF. It is also suggested to use a R_{RCIN} of between 0.5M Ω and 2M Ω .

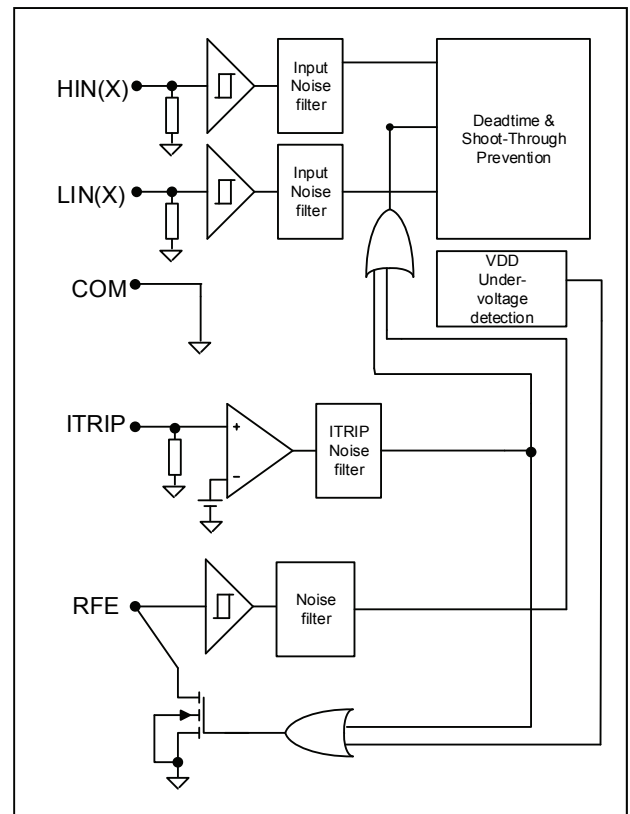

Figure 6 RFE internal circuit structure

U,V,W (High side emitter and low side collector)

These pins are motor U, V, W input pins.

P (Positive bus input voltage)

The high side IGBTs are connected to the bus voltage. It is noted that the bus voltage does not exceed 450V.

Absolute Maximum Rating

3 Absolute Maximum Rating

3.1 Module

Table 3

Parameter	Symbol	Conditions	Value	Units
Operating junction temperature	T_J	IGBT, diode, HVIC	-40 ~ 150	°C
Operating case temperature	T_C		-40 ~ 125	°C
Storage temperature	T_{STG}		-40 ~ 125	°C
Isolation test voltage	V_{ISO}	AC RMS, 1 minute, 60Hz	2000	V

3.2 Inverter

Table 4

Parameter	Symbol	Conditions	Value	Units
Blocking voltage	V_{CES}	IGBT, diode, HVIC	600	V
DC –link supply voltage of P-N	V_{PN}	Applied between P and N	450	V
DC –link supply voltage (surge) of P-N	$V_{PN(surge)}$	Applied between P and N	500	V
Output current	I_O	$T_C = 25^\circ\text{C}, T_J < 150^\circ\text{C}$	± 10	A
Peak output current	$I_{O(peak)}$	$T_C = 25^\circ\text{C}, T_J < 150^\circ\text{C}$, less than 1ms	± 15	A
Power dissipation per IGBT	P_{tot}		20	W
Short Circuit withstand time	T_{SC}	$T_J < 150^\circ\text{C}, V_{DC} = 360\text{V}, V_{GE} = 15\text{V}$	3	μs

3.3 Control

Table 5

Parameter	Symbol	Conditions	Value	Units
Logic supply voltage	V_{DD}		-0.3 ~ 20	V
Input voltage	V_{IN}	LIN, HIN, ITRIP, RFE	-0.3 ~ 20	V
High side floating supply voltage	$V_{BS(U,V,W)}$		-0.3 ~ 20	V

4 Thermal Characteristics

Table 6

Parameter	Symbol	Conditions	Value			Units
			Min.	Typ.	Max.	
Single IGBT thermal resistance, junction-case	$R_{TH(J-C)}$	Low side W-phase IGBT (See Figure 8 for T_c measurement point)	-	5.3	6.1	°C/W
Single diode thermal resistance, junction-case	$R_{TH(J-C)D}$	Low side W-phase diode (See Figure 8 for T_c measurement point)	-	6.6	7.7	°C/W

5 Recommended Operating Conditions

For proper operation the device should be used within the recommended conditions. All voltages are absolute referenced to COM. The VS offset is tested with all supplies biased at 15V differential.

Table 7

Parameter	Symbol	Conditions	Value			Units
			Min.	Typ.	Max.	
Positive DC bus input voltage	V_{DC}		-	-	450	V
Low side control supply voltage	V_{DD}		13.5	15	16.5	V
High side floating supply voltage	V_{BS}		12.5	15	17.5	V
Input voltage	V_{IN}	LIN, HIN, ITRIP, RFE	0	-	5	V
PWM carrier frequency	F_{PWM}		-	20	-	kHz
Voltage between COM and N (including surge)	V_{COM}		-5	-	5	V
External dead time between HIN & LIN	DT		1	-	-	μ s
Input pulse width	$PW_{IN(ON)}$ $PW_{IN(OFF)}$		1	-	-	μ s

6 Static Parameters

6.1 Inverter

$V_{BIAS}(V_{DD}, V_{BS(U,V,W)})=15V$, $T_J=25^\circ C$ unless otherwise specified

Table 8

Parameter	Symbol	Conditions	Value			Units
			Min.	Typ.	Max.	
Collector-Emitter saturation voltage	$V_{CE(ON)}$	$I_C = 5A$	-	1.5	1.9	V
		$I_C = 5A, T_J = 150^\circ C$	-	1.7	-	V
Collector-Emitter leakage current	I_{CES}	$V_{IN} = 0V, V_{CE} = 600V$	-	10	80	μA
		$V_{IN} = 0V, V_{CE} = 600V, T_J=150^\circ C$	-	80	-	μA
Diode forward voltage drop	V_F	$I_C = 5A$	-	1.7	2.2	V
		$I_C = 5A, T_J = 150^\circ C$	-	1.6	-	V

6.2 Control

$V_{BIAS}(V_{DD}, V_{BS(U,V,W)})=15V$, $T_J=25^\circ C$, unless otherwise specified. The V_{IN} parameters are referenced to COM and are applicable to all six channels

Table 9

Parameter	Symbol	Conditions	Value			Units
			Min.	Typ.	Max.	
Logic "1" input voltage	$V_{IN,TH+}$	LIN, HIN, RFE	2.5	-	-	V
Logic "0" input voltage	$V_{IN,TH-}$	LIN, HIN, RFE	-	-	0.8	V
V_{DD}/V_{BS} supply undervoltage, positive going threshold	$V_{DD,UV+}, V_{BS,UV+}$		9.6	10.4	11.2	V
V_{DD}/V_{BS} supply undervoltage, negative going threshold	$V_{DD,UV-}, V_{BS,UV-}$		8.6	9.4	10.2	V
V_{DD}/V_{BS} supply undervoltage lock-out hysteresis	V_{DDUVH}, V_{BSUVH}		-	1	-	V
Quiescent V_{BS} supply current	I_{QBS}		-	-	150	μA
Quiescent V_{DD} supply current	I_{QDD}		-	-	3.2	mA
Offset supply leakage current	I_{LK}	$V_S = 600V$	-	-	50	μA
Input bias current for LIN, HIN	I_{IN+}	$V_{IN} = 3.3V$	-	825	1110	μA
Input bias current for RFE	$I_{IN,RFE+}$	$V_{REF} = 3.3V$	-	0	1	μA
Input bias current for ITRIP	I_{TRIP+}	$V_{ITRIP} = 3.3V$	-	4	16	μA
ITRIP threshold voltage	V_{ITRIP}		0.44	0.49	0.54	V

Static Parameters

Parameter	Symbol	Conditions	Value			Units
			Min.	Typ.	Max.	
ITRIP input hysteresis	$V_{ITRIP,HYS}$		-	0.07	-	V
Bootstrap resistance	R_{BS}		-	200	-	Ω
RFE low on resistance	R_{RFE}		-	50	100	Ω

7 Dynamic Parameters

7.1 Inverter

$V_{BIAS}(V_{DD}, V_{BS(U,V,W)})=15V$, $T_J=25^\circ C$, unless otherwise specified.

Table 10

Parameter	Symbol	Conditions	Value			Units
			Min.	Typ.	Max.	
Input to output turn-on propagation delay	T_{ON}	$I_C = 5A, V_{DC} = 300V$	-	-	1.15	μs
Input to output turn-off propagation delay	T_{OFF}	$I_C = 5A, V_{DC} = 300V$	-	-	1.15	μs
RFE low to six switch turn-off propagation delay	T_{EN}	$V_{RFE} = 5V \text{ to } 0V$	-	-	1.35	μs
ITRIP to six switch turn-off propagation delay	T_{ITRIP}	$I_C = 5A, V_{DC} = 300V$	-	-	1.5	μs
IGBT turn-on energy	E_{ON}	$V_{DC} = 300V, I_C = 5A,$ $T_J = 25^\circ C$ $150^\circ C$	-	170	-	μJ
IGBT turn-off energy	E_{OFF}	$V_{DC} = 300V, I_C = 5A,$ $T_J = 25^\circ C$ $150^\circ C$	-	70	-	μJ
Diode reverse recovery energy	E_{REC}	$V_{DC} = 300V, I_C = 5A,$ $T_J = 25^\circ C$ $150^\circ C$	-	20	-	μJ
Reverse Bias Safe Operating Area	RBSOA	$T_J = 150^\circ C, I_C = 20A, V_P = 600V,$ $V_{DC} = 450V, V_{DD} = +15V \text{ to } 0V$	FULL SQUARE			

7.2 Control

$V_{BIAS}(V_{DD}, V_{BS(U,V,W)})=15V$, $T_J=25^\circ C$, unless otherwise specified.

Table 11

Parameter	Symbol	Conditions	Value			Units
			Min.	Typ.	Max.	
Input filter time (HIN, LIN, ITRIP)	T_{FILIN}	$V_{IN} = 0 \text{ or } V_{IN} = 5V$	-	350	-	ns
Input filter time (RFE)	T_{FILRFE}	$V_{RFE} = 0 \text{ or } V_{RFE} = 5V$	100	200	-	ns
ITRIP to Fault propagation delay	T_{FLT}	$V_{IN} = 0 \text{ or } V_{IN} = 5V, V_{ITRIP} = 5V$	400	600	800	ns
Internal injected dead time	T_{DT}	$V_{IN} = 0 \text{ or } V_{IN} = 5V$	190	275	420	ns
Matching propagation delay time (On & Off) all channels	M_T	External dead time > 420ns	-	-	50	ns

8 Thermistor Characteristics

Table 12

Parameter	Symbol	Conditions	Value			Units
			Min.	Typ.	Max.	
Resistance	R_{25}	$T = 25^{\circ}\text{C}$, $\pm 5\%$ tolerance	44.65	47	49.35	$\text{k}\Omega$
Resistance	R_{125}	$T = 125^{\circ}\text{C}$	1.27	1.41	1.56	$\text{k}\Omega$
B-constant	B	$25\text{-}50^{\circ}\text{C}$, $R_2 = R_1 e^{[B(1/T_2 - 1/T_1)]}$	3989	4050	4111	K
Temperature Range			-40	-	125	$^{\circ}\text{C}$

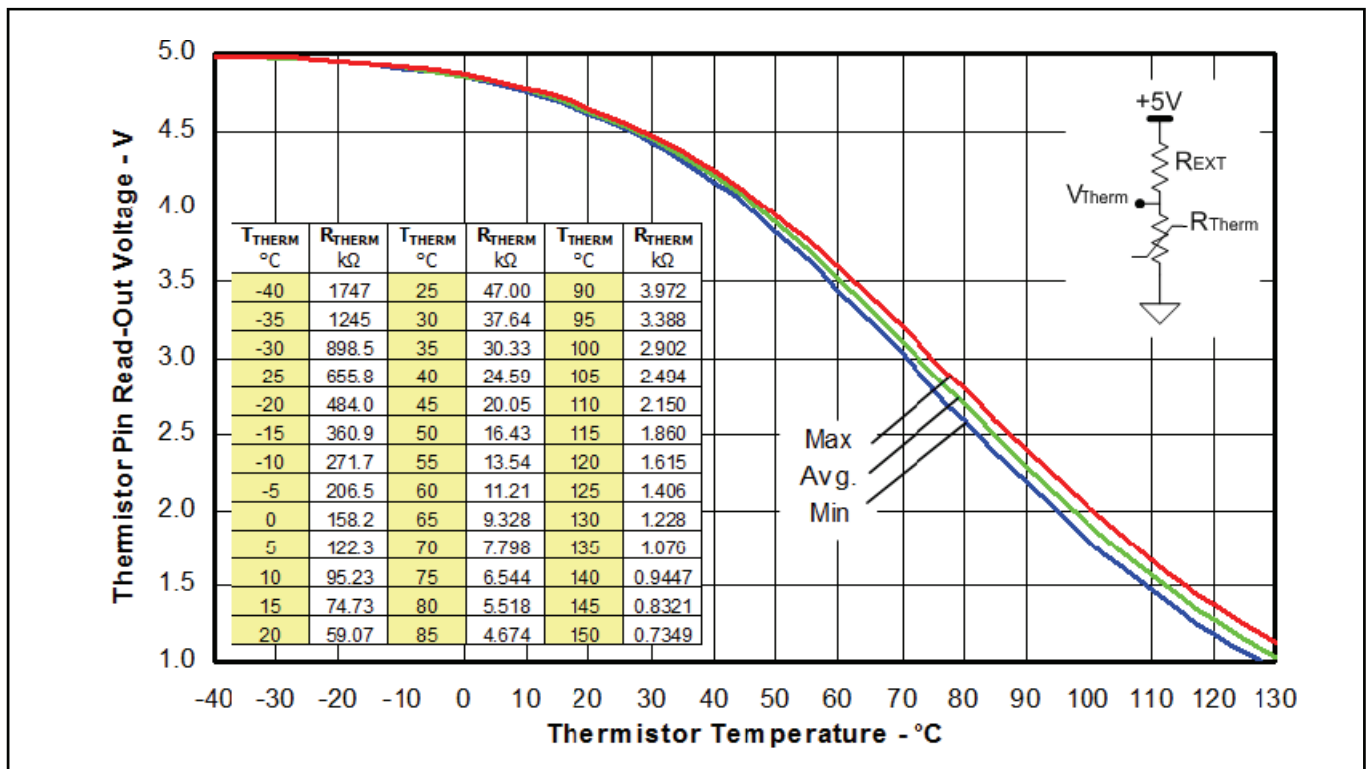

Figure 7 Thermistor readout vs. temperature (with 4.7kohm R_{EXT} pull-down resistor) and typical thermistor resistance values vs. temperature table

9 Mechanical Characteristics and Ratings

Table 13

Parameter	Symbol	Conditions	Value			Units
			Min.	Typ.	Max.	
Thermal resistance, case-heatsink	$R_{TH(C-S)}$	Flat, greased surface. Heatsink compound thermal conductivity 1W/mK	-	0.25	-	°C/W
Comparative Tracking Index	CTI		600	-	-	V
Curvature of module backside	BKC		0	-	150	μm
Mounting torque	T	M3 screw and washer	0.6	0.7	0.8	Nm

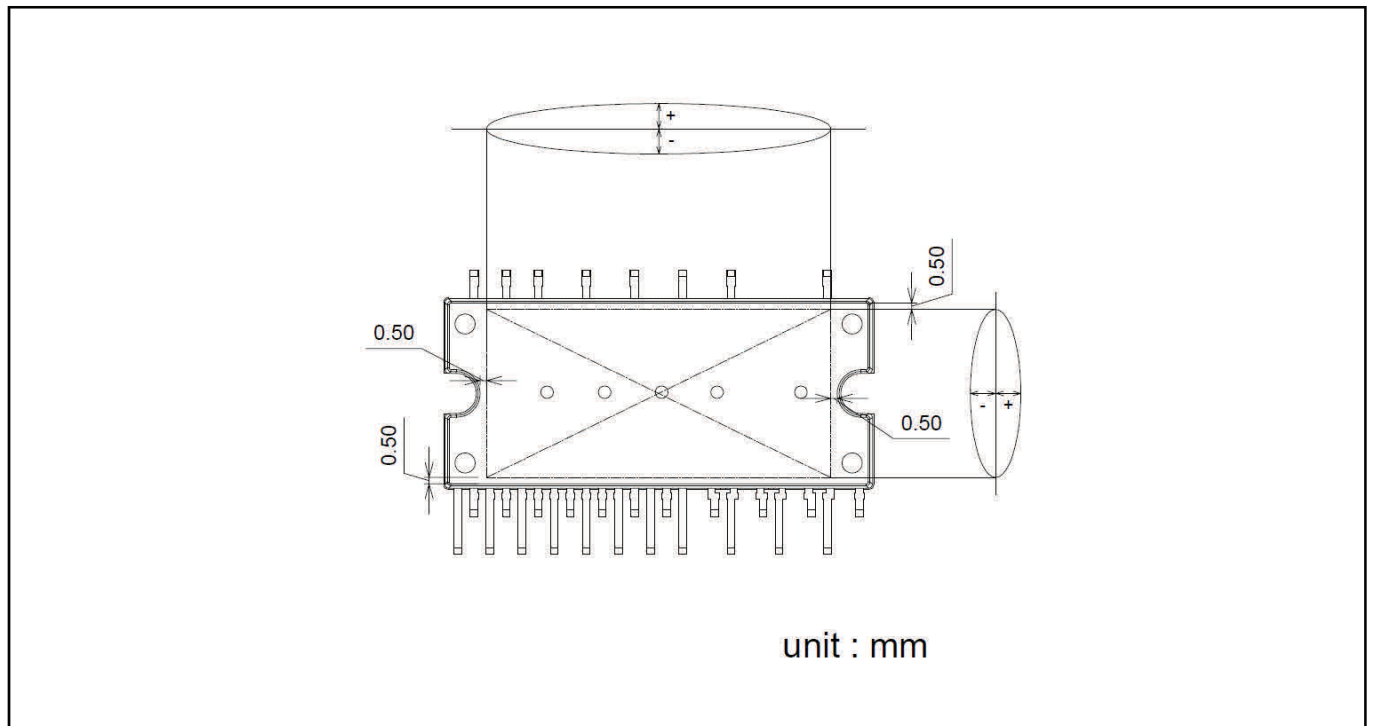

Figure 8 Backside curvature measurement position

10 Qualification Information

Table 14

UL Certified	File Number E314539	
RoHS Compliant	Yes	
ESD	Human body model	Class 3A
	Charge discharge model	Class C3

11 Diagram & Tables

11.1 Tc Measurement Point

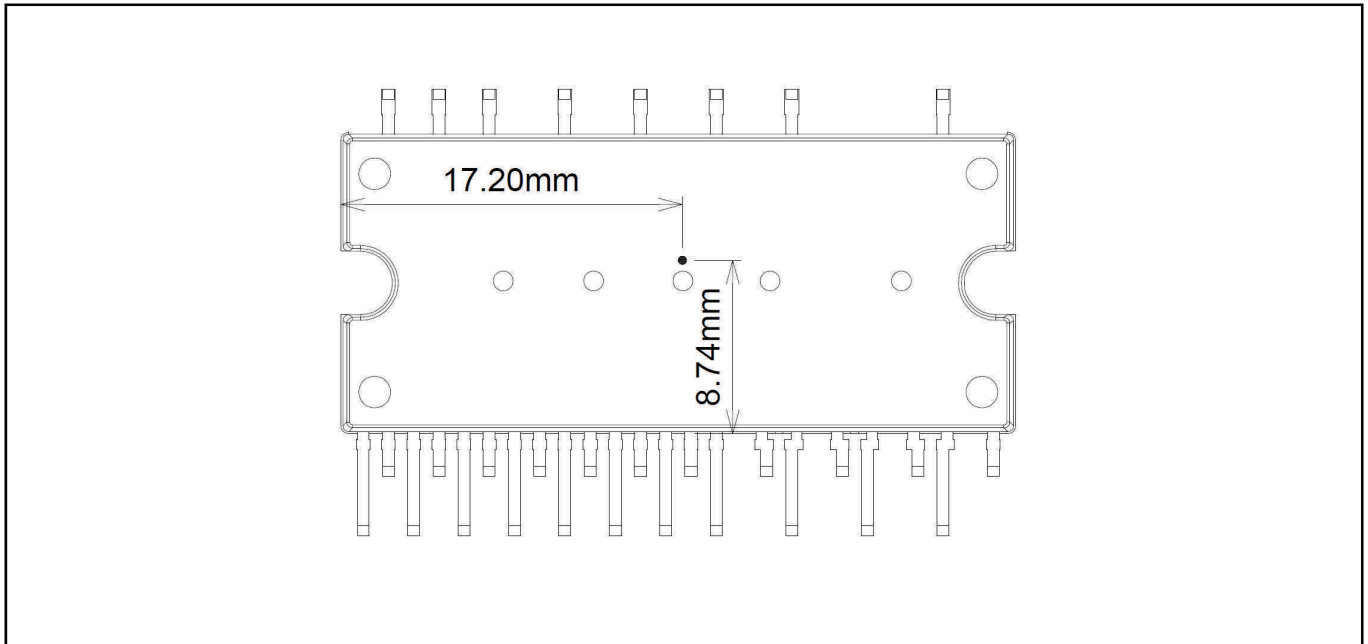

Figure 9 TC measurement point

11.2 Input-Output Logic Table

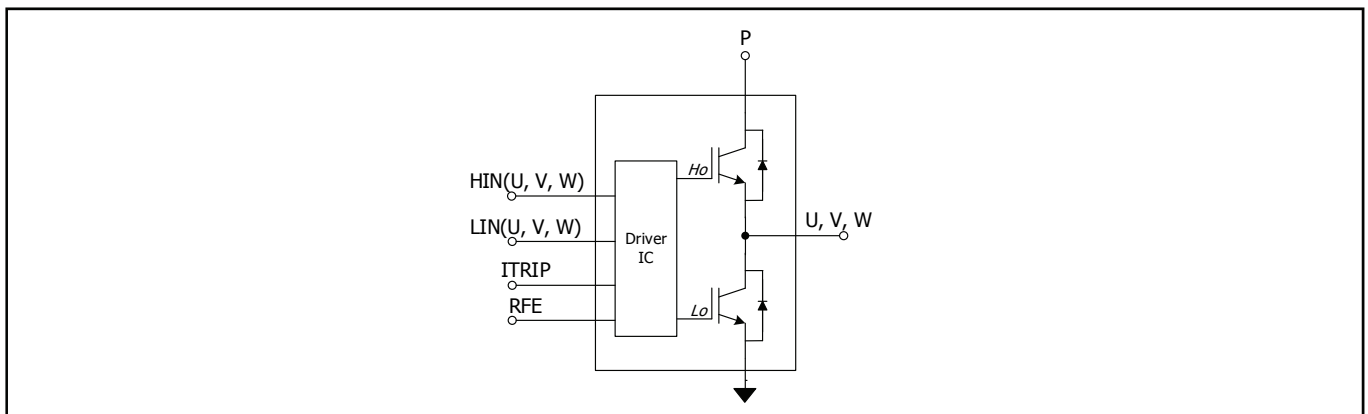

Figure 10 Module block diagram

Table 15 Input-output logic level table

RFE	ITRIP	HIN(U,V,W)	LIN(U,V,W)	U,V,W
1	0	1	0	V_{DC}
1	0	0	1	0
1	0	0	0	Off
1	0	1	1	Off
1	1	X	X	Off
0	X	X	X	Off

11.3 Switching Time Definitions

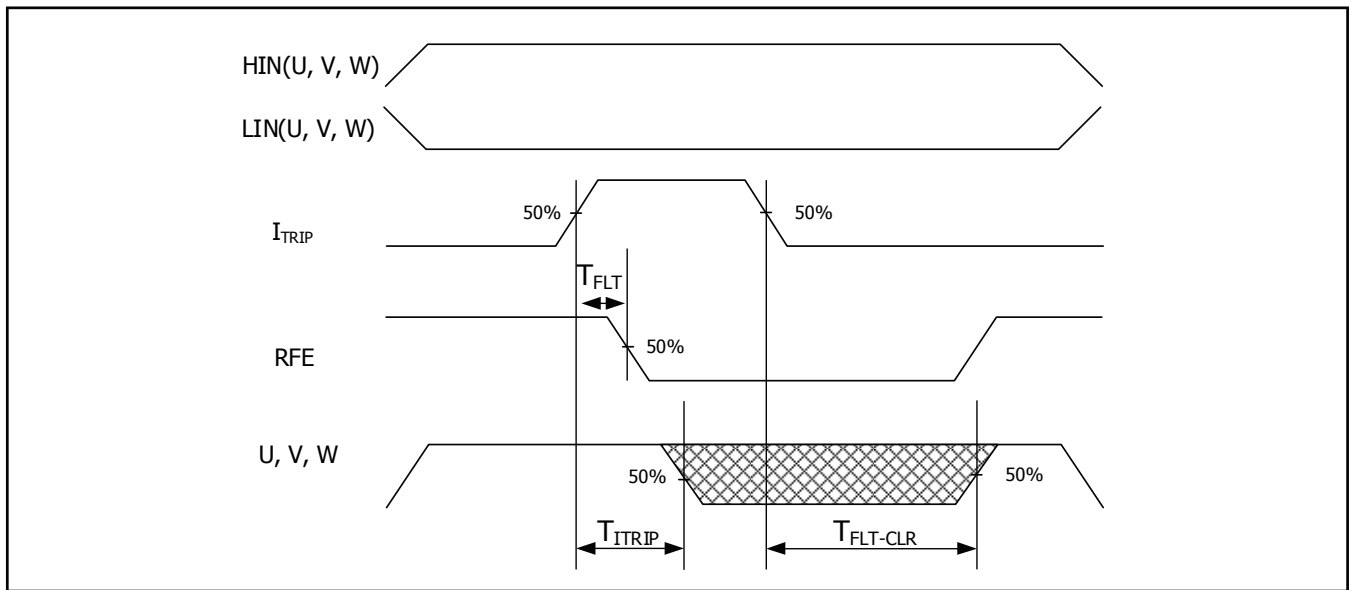

Figure 11 ITRIP time waveform

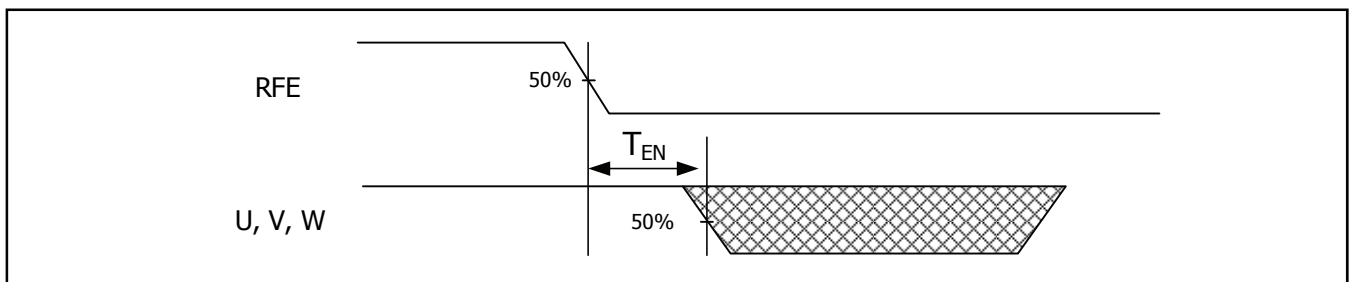

Figure 12 Output disable timing diagram

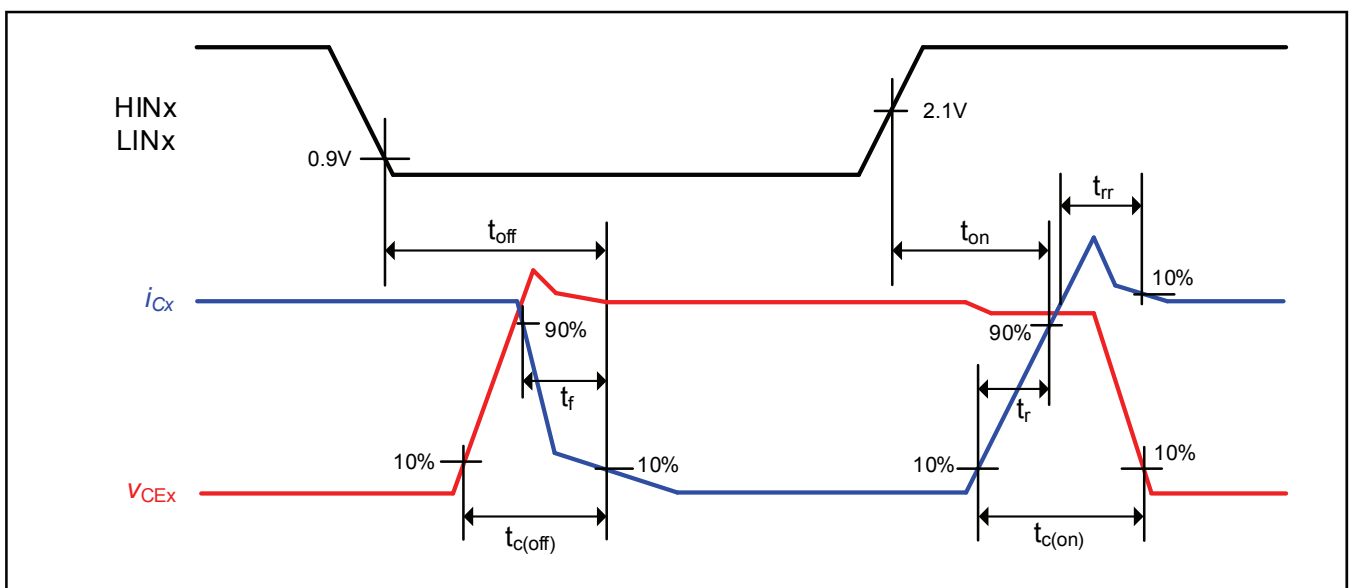

Figure 13 Switching times definition

12 Application Guide

12.1 Typical Application Schematic

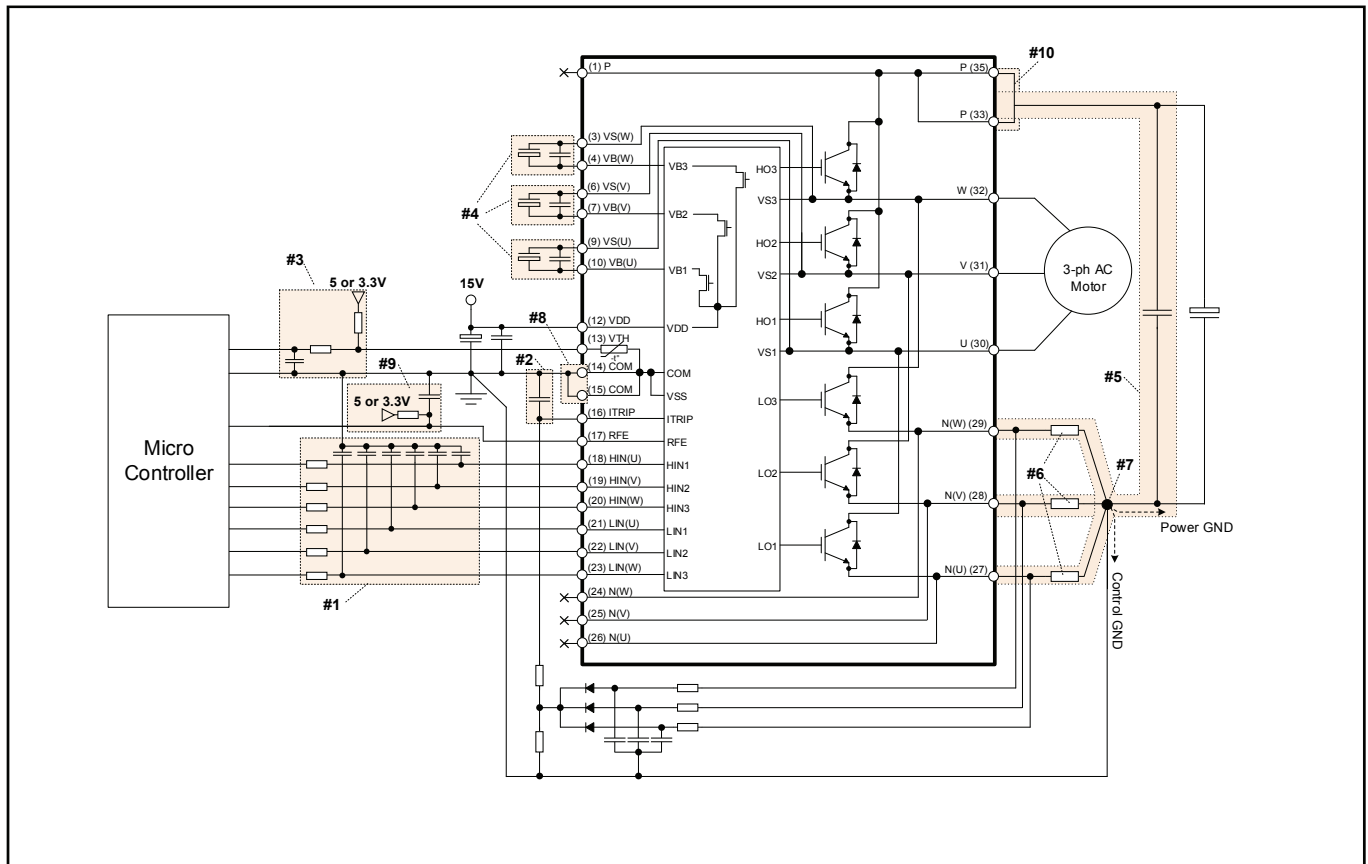

Figure 14 Typical application connection

1. Input circuit
 - RC filter can be used to reduce input signal noise (100Ω, 1nF)
 - The capacitors should be located close to CIPOS™ Tiny (to COM terminal especially).
2. Itrip circuit
 - To prevent a mis operation of protection function, RC filter is recommended
 - The capacitor must be located close to Itrip and COM terminals.
3. VTH circuit
 - This terminal should be pulled up to the bias voltage of 5V/3.3V through a proper resistor to define suitable voltage for temperature monitoring.
 - It is recommended that RC filter is placed close to the controller
4. VB-VS circuit
 - Capacitors for high side floating supply voltage should be placed close to VB and VS terminals.
 - Additional high frequency capacitors, typically 0.1mF, are strongly recommended.
 - Overlap of pattern to motor and pattern to bootstrap capacitors should be minimized.
5. Snubber capacitor
 - The wiring among CIPOS™ Tiny, snubber capacitor and shunt resistors should be short as possible.
6. Shunt resistor
 - SMD type shunt resistors are strongly recommended to minimize its internal stray inductance.
7. Ground pattern
 - Pattern overlap of power ground and signal ground should be minimized. The patterns should be connected at the common end of shunt resistors only for the same potential.
8. COM pattern
 - Both of the COM terminals should be connected together.
9. RFE circuit
 - To setup R and C parameter for fault clear time, please refer to Figure 5.
 - This R is also mandatory for fault out reporting function because it is open drain structure.
10. P pattern
 - Both of the P terminals should be connected together.

12.2 Performance Charts

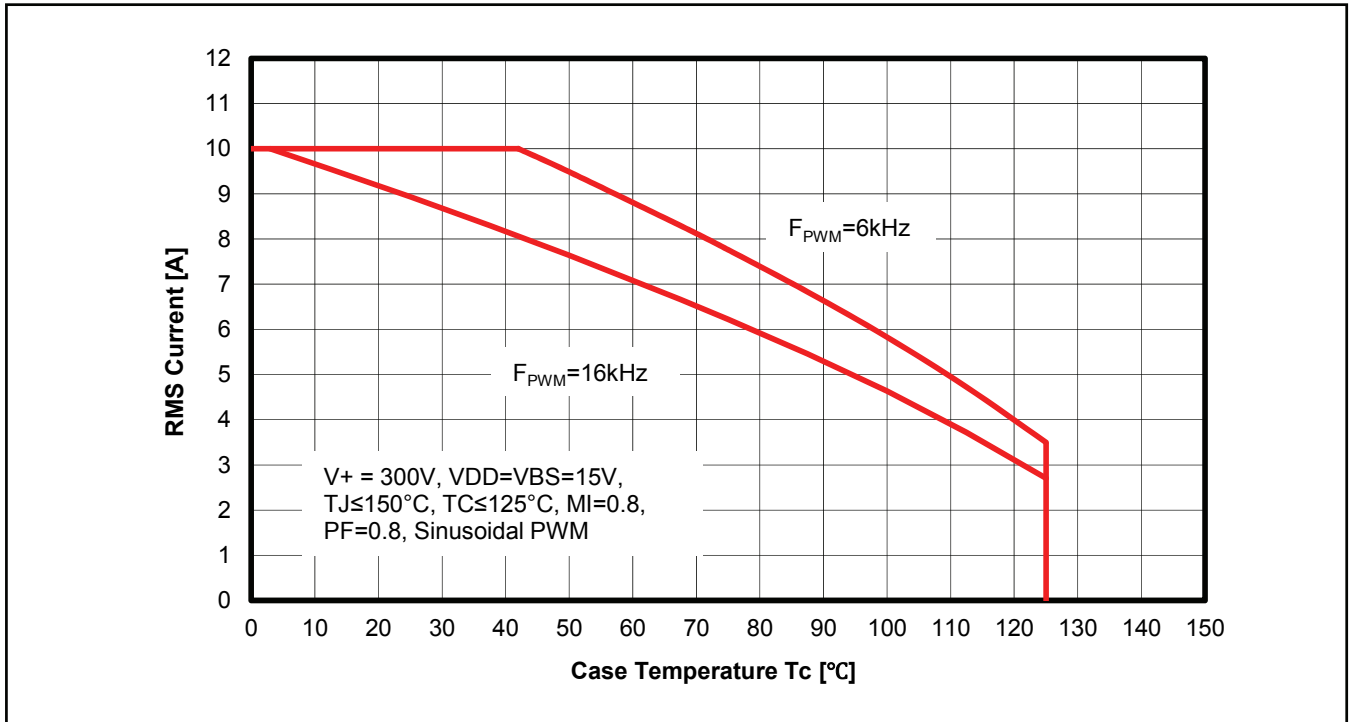

Figure 15 Maximum operating current SOA

1. This maximum operating current SOA is just one of example based on typical characteristics for this product. It can be change by each user's actual operating conditions.

12.3 Tj vs. Tth

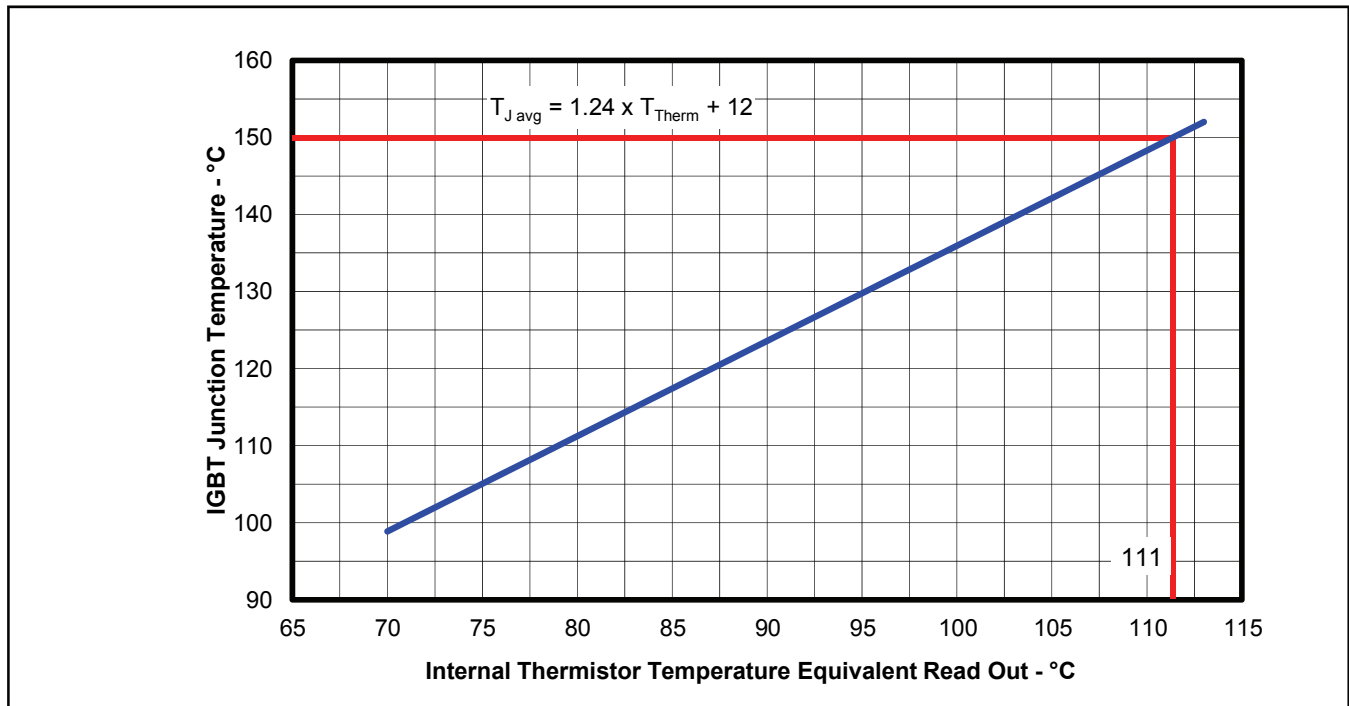

Figure 16 Typical Tj vs Tth correlation, sinusoidal modulation, V_{DC}=300V, I_{phase}=5Arms, f_{sw}=16kHz, f_{mod}=50Hz, MI=0.8, PF=0.6

12.2 -V_s Immunity

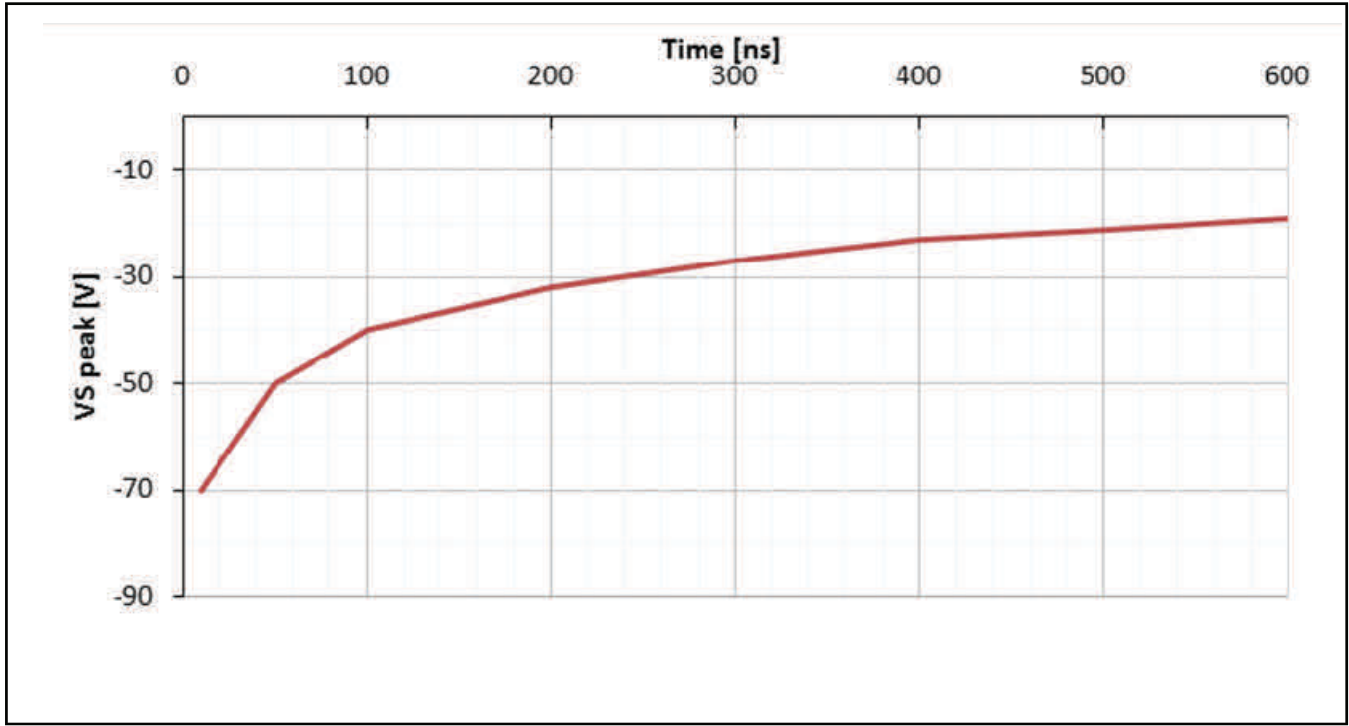

Figure 17 Negative transient Vs SOA for integrated gate driver

Package Information

13 Package Outline

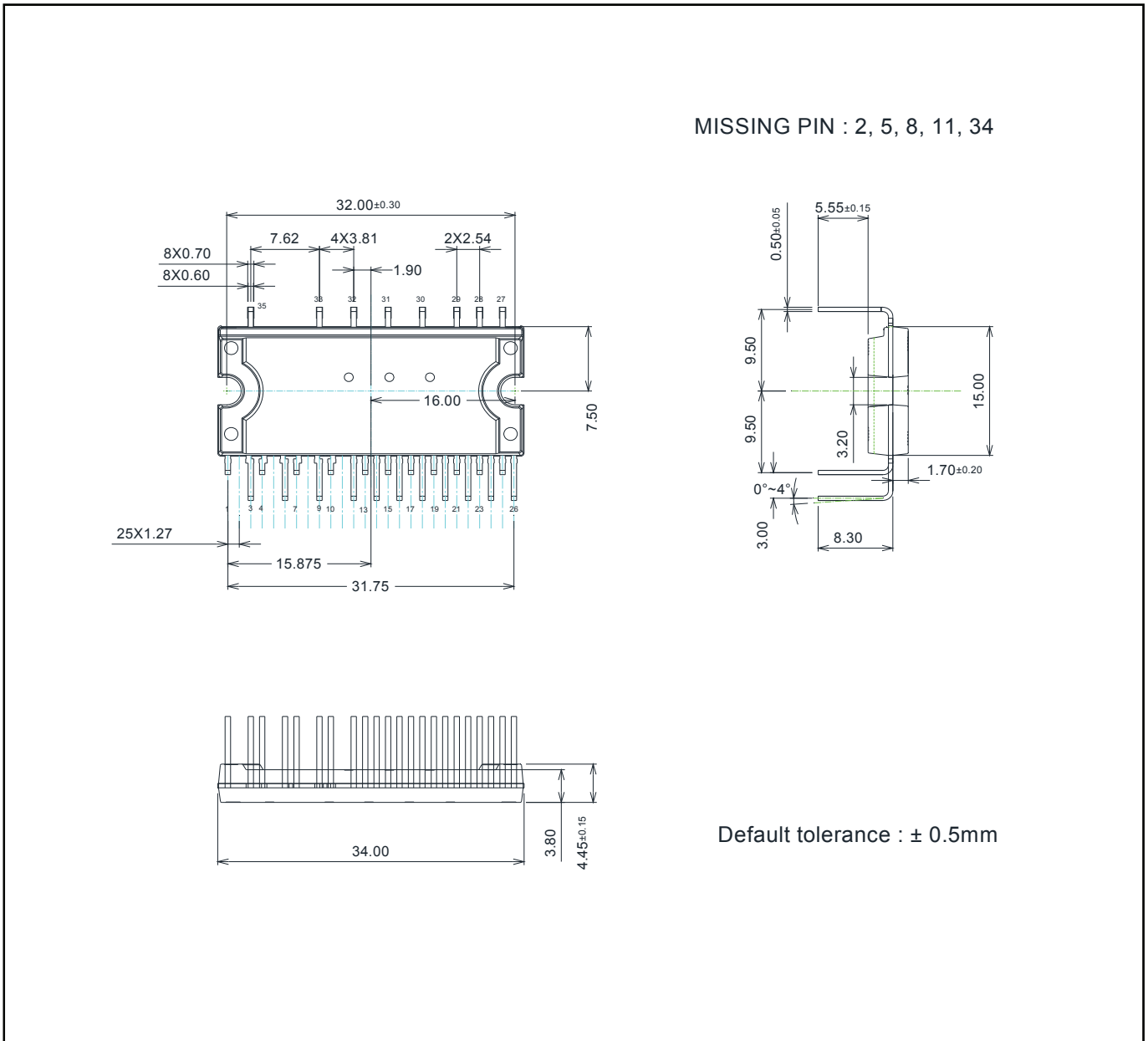

Figure 18 IM393-M6E

Package Information

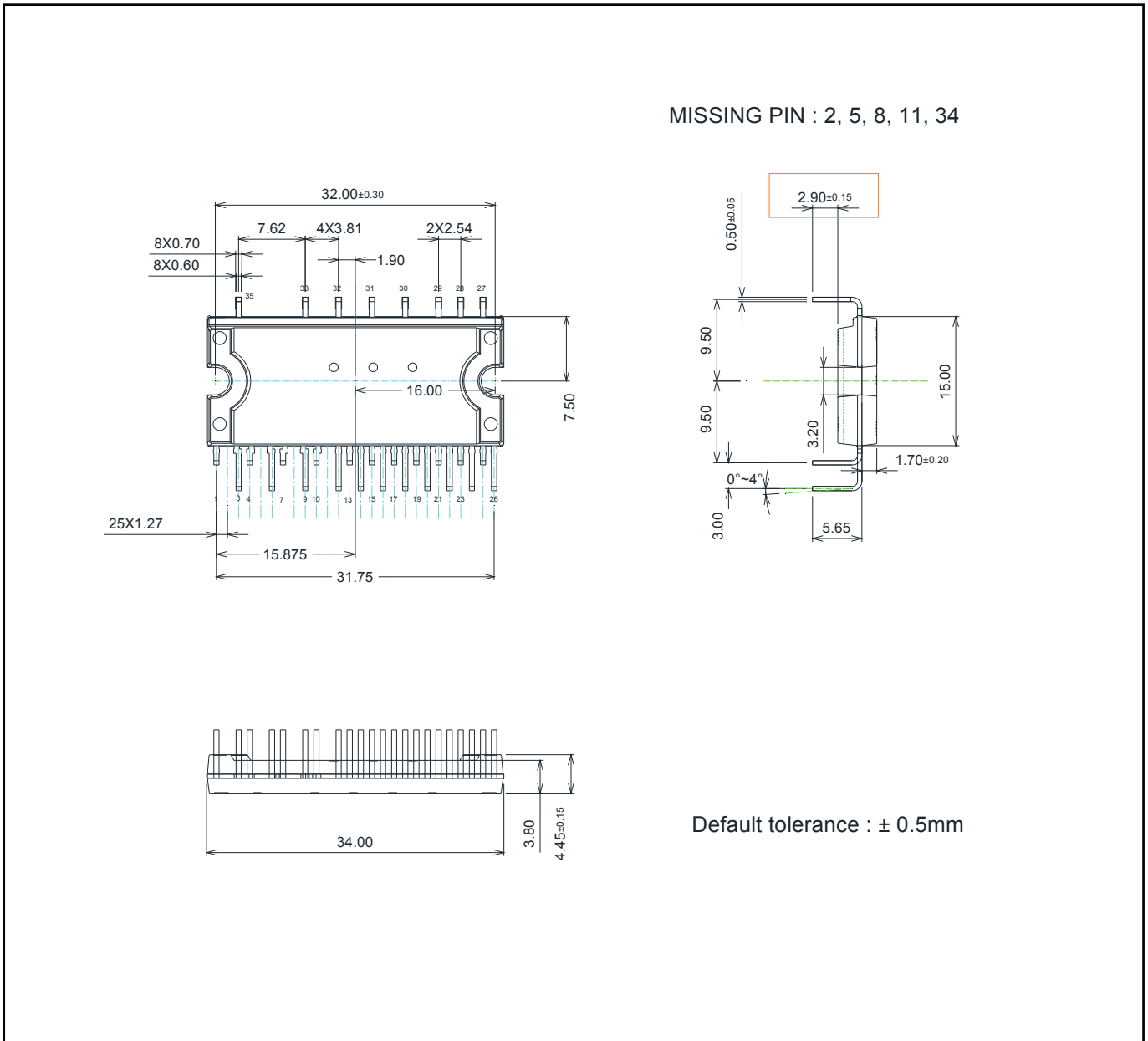

Figure 19 IM393-M6E2

Package Information

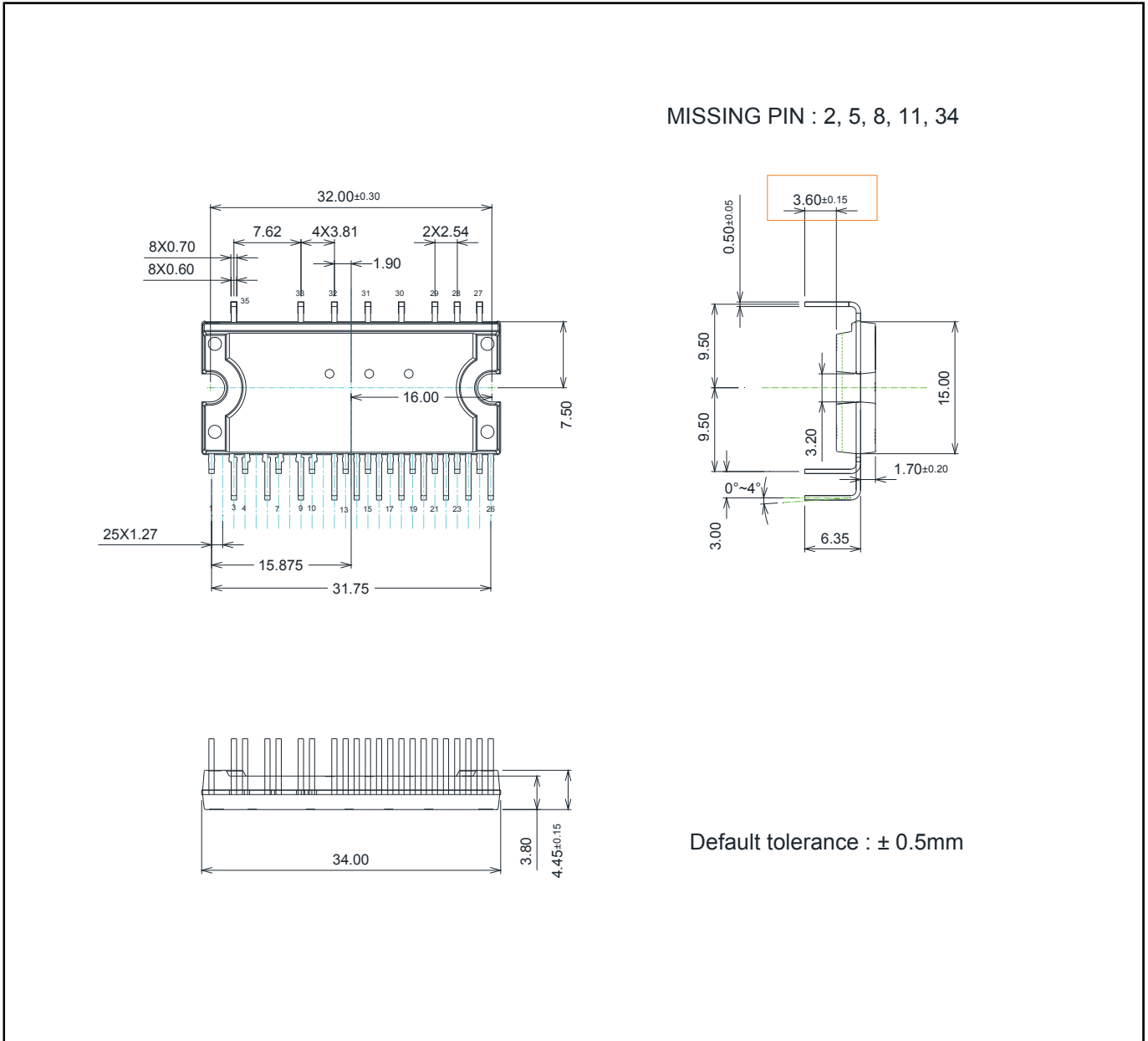

Figure 20 IM393-M6E3

Revision History

Revision History

Major changes since the last revision

Page or Reference	Revision	Date	Description of changes

Other Trademarks

All referenced product or service names and trademarks are the property of their respective owners.

Edition 2017-09-26
Published by
Infineon Technologies AG
81726 Munich, Germany

© 2017 Infineon Technologies AG.
All Rights Reserved.

Do you have a question about this document?

Email: erratum@infineon.com

Document reference

IMPORTANT NOTICE

The information given in this document shall in no event be regarded as a guarantee of conditions or characteristics ("Beschaffenheitsgarantie").

With respect to any examples, hints or any typical values stated herein and/or any information regarding the application of the product, Infineon Technologies hereby disclaims any and all warranties and liabilities of any kind, including without limitation warranties of non-infringement of intellectual property rights of any third party.

In addition, any information given in this document is subject to customer's compliance with its obligations stated in this document and any applicable legal requirements, norms and standards concerning customer's products and any use of the product of Infineon Technologies in customer's applications.

The data contained in this document is exclusively intended for technically trained staff. It is the responsibility of customer's technical departments to evaluate the suitability of the product for the intended application and the completeness of the product information given in this document with respect to such application.

For further information on the product, technology, delivery terms and conditions and prices please contact your nearest Infineon Technologies office (www.infineon.com).

WARNINGS

Due to technical requirements products may contain dangerous substances. For information on the types in question please contact your nearest Infineon Technologies office.

Except as otherwise explicitly approved by Infineon Technologies in a written document signed by authorized representatives of Infineon Technologies, Infineon Technologies' products may not be used in any applications where a failure of the product or any consequences of the use thereof can reasonably be expected to result in personal injury.