

# MARKETING SALES DRAWING

**DIMENSIONS IN INCHES - DO NOT SCALE THIS DRAWING**  
**DIMENSIONS IN METRIC - [ ]**

This drawing is the property of Tusonix, Inc., and may not be used, reproduced, published or disclosed to others without expressed authorization by Tusonix Inc.

**Electrical Testing**  
 per Tusonix standard  
 test plans and Mil-Std-202  
 Test Methods.

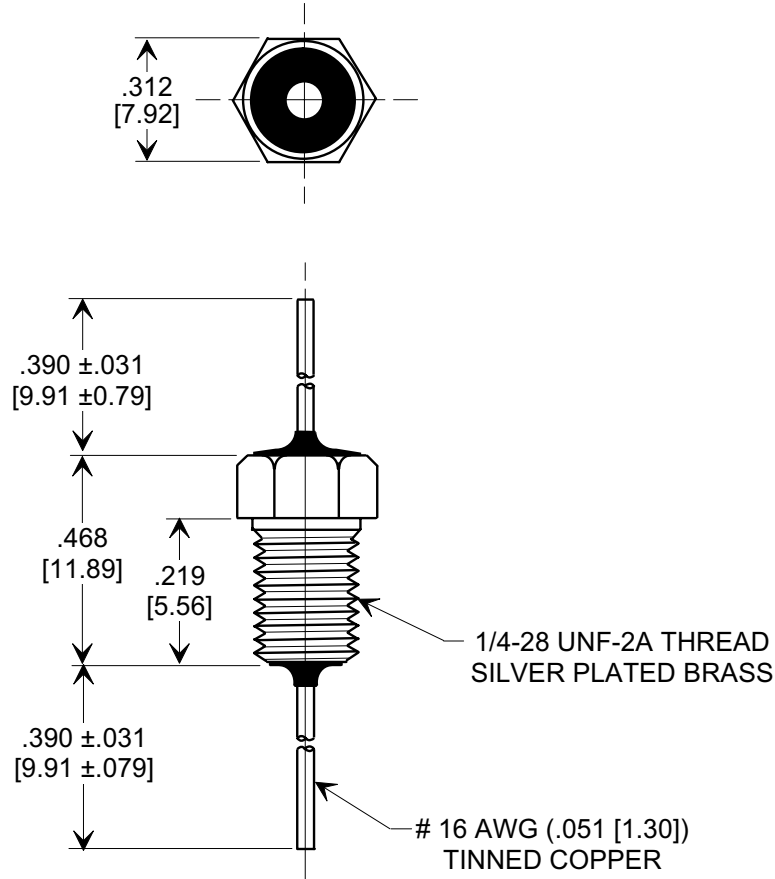
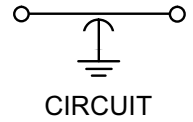
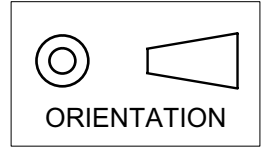

## SPECIFICATIONS

TUSONIX STYLE:	2443-008
VALUE:	1500 pF
VALUE TOL.:	± 20%
TEMP. COEF.:	X5S
RATING:	500 WVDC @ 85°C
OPERATING RANGE:	-55°C TO +85°C
DWV (VDC)	1500
I.R. MIN. @ 100 (VDC)	10 G Ω

## NOTES:

- TUSONIX STANDARD PART NUMBER: 2443-008-X5S0-152M. TUSONIX RoHS COMPLIANT PART NUMBER: 2443-008-X5S0-152M LF. CUSTOMER MUST SPECIFY STANDARD OR RoHS PART NUMBER WHEN ORDERING.
- PART MARKING: TRADEMARK, CAPACITANCE AND TOLERANCE CODE: STANDARD PART: BLACK INK. RoHS PART: GREEN INK.
- SUPPLIED WITH SILVER PLATED HEX NUT AND LOCK WASHER, BULK PACKAGED.

<b>REVISION RECORD</b> Original Release C.O. 19980728-3-01 ADDED METRIC, DWV & I.R. ADDED & REVISED NOTES. S.M. 12-15-06 20061215-1-01	0	1	--TOLERANCES-- Unless Otherwise Specified	Title <b>BUSHING TYPE FEED-THRU CAPACITOR</b>	
	DECIMAL ± .015 [0.38]		Drawn S.M. 07-29-98		
	ANGLES ±		Approved J.Mc. 07-29-98		
	<b>TUSONIX</b> TUCSON, ARIZONA		<b>A</b>	<b>2443-008-X5S0-152M</b>	