

## Electronic housing - UEGM 25 BK OHNE LOGO - 2757306

Please be informed that the data shown in this PDF Document is generated from our Online Catalog. Please find the complete data in the user's documentation. Our General Terms of Use for Downloads are valid (<http://phoenixcontact.com/download>)



Electronic housing, for PCB insertion, fully equipped with 3 screw or 6 tab connections per side

The figure shows a green version



### Key Commercial Data

Packing unit	10 pc
GTIN	 4 017918 272739
GTIN	4017918272739

### Technical data

#### General

Housing type	Component housing
Housing material	Polyamide (PA 6.6)
Color (RAL)	black

#### Ambient conditions

Ambient temperature (operation)	-40 °C ... 105 °C
---------------------------------	-------------------

#### Dimensions

Length	79 mm
Width	25 mm

#### Technical data

Connection in acc. with standard	CUL
Nominal voltage $U_N$	300 V
Nominal current $I_N$	10 A
AWG/kcmil	30-12
Indicator1	CUL1
Number of positions	6

# Electronic housing - UEGM 25 BK OHNE LOGO - 2757306

## Technical data

### Standards and Regulations

Connection in acc. with standard	CUL
Flammability rating according to UL 94	V2

### Environmental Product Compliance

REACH SVHC	Lead 7439-92-1
China RoHS	Environmentally Friendly Use Period = 50
	For details about hazardous substances go to tab "Downloads", Category "Manufacturer's declaration"

## Drawings

Explosion drawing

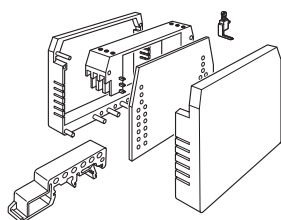

Dimensional drawing

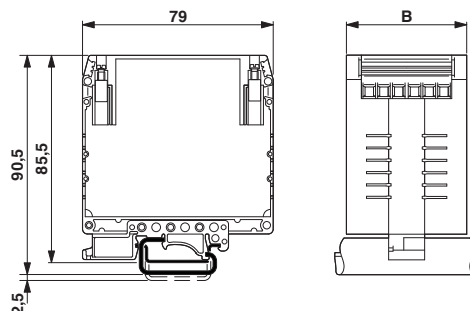

Dimensional drawing

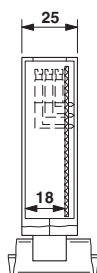

Dimensional drawing

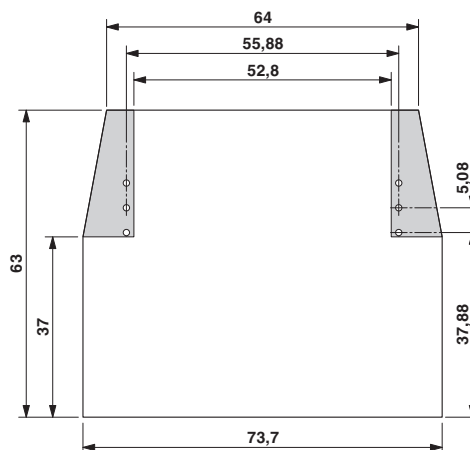

UEGM 25... und UEGM 27,5-SMD with 1 PCB, 6 positions or 12 positions (FS/FS)

# Electronic housing - UEGM 25 BK OHNE LOGO - 2757306

Schematic diagram

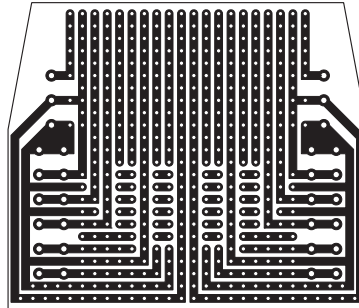

## Approvals

Approvals

Approvals

UL Recognized / EAC / cULus Recognized

Ex Approvals

## Approval details

UL Recognized		<a href="http://database.ul.com/cgi-bin/XYV/template/LISEXT/1FRAME/index.htm">http://database.ul.com/cgi-bin/XYV/template/LISEXT/1FRAME/index.htm</a>	FILE E 240868
---------------	--	---	---------------

EAC			B.01742
-----	--	--	---------

cULus Recognized		<a href="http://database.ul.com/cgi-bin/XYV/template/LISEXT/1FRAME/index.htm">http://database.ul.com/cgi-bin/XYV/template/LISEXT/1FRAME/index.htm</a>	E60425-19770427
------------------	--	---	-----------------

Nominal voltage UN	300 V
Nominal current IN	10 A
mm <sup>2</sup> /AWG/kcmil	30-12

Phoenix Contact 2018 © - all rights reserved  
<http://www.phoenixcontact.com>

PHOENIX CONTACT GmbH & Co. KG  
Flachsmarktstr. 8  
32825 Blomberg  
Germany  
Tel. +49 5235 300  
Fax +49 5235 3 41200  
<http://www.phoenixcontact.com>